

DEPARTMENT OF THE ARMY TECHNICAL MANUAL

OPERATOR, ORGANIZATIONAL, AND
DIRECT SUPPORT MAINTENANCE MANUAL
(INCLUDING REPAIR PARTS AND
SPECIAL TOOLS LIST)

FIELD ARTILLERY TRAINER KITS
(WITH FIELD ARTILLERY TRAINER M31)

This copy is a reprint which includes current
pages from Changes 1 and 2.

HEADQUARTERS, DEPARTMENT OF THE ARMY

SEPTEMBER 1976

WARNING

If you're extracting a live round, pull bolt back S-L-O-W-L-Y. Firing pin will move forward as bolt is moved rearward. Misfire device should be used.

WARNING

Before starting an inspection, be sure to clear the trainer or subcaliber device. Do not actuate the firing mechanism until the weapon has been cleared. Inspect the receiver to insure that it is empty and check to see that no ammunition is in position to be introduced. Avoid having live ammunition in the vicinity of the work.

WARNING

The projectile fired by the trainer does not fragment when ignited. Do not fire the trainer if there are troops deployed forward of the line of fire.

WARNING

Because the M31 has no recoil, crewmen may develop unsafe habits which would lead to injury during live fire. Batteries should practice, and become proficient in, occupying positions at realistic distances before training on the reduced scale 14.5-mm range. The lanyard holder assembly should always be used to fire the M31 when installed as a subcaliber device.

CHANGE

No. 2

HEADQUARTERS
DEPARTMENT OF THE ARMY
Washington, DC, 5 August 1985

OPERATOR, ORGANIZATIONAL, AND
DIRECT SUPPORT MAINTENANCE MANUAL
(INCLUDING REPAIR PARTS AND SPECIAL TOOLS LIST)
FIELD ARTILLERY TRAINER KITS
(WITH FIELD ARTILLERY TRAINER M31)

TM 9-6920-361-13&P, 22 September 1976, is changed as follows:

1. Remove old pages and insert new pages as indicated below. New or changed material is indicated by a vertical bar in the margin of the page.

Remove Pages

1-1 and 1-2
4-1 and 4-2
A-1/(A-2 Blank)
C-7 through C-10

Insert Pages

1-1 and 1-2
4-1 and 4-2
A-1/(A-2 Blank)
C-7 through C-10

File this and other change sheets in back of the publication for reference purposes.

By Order of the Secretary of the Army:

JOHN A. WICKHAM, JR.
General, United States Army
Chief of Staff

Official:

DONALD J. DELANDRO
Brigadier General, United States Army
The Adjutant General

DISTRIBUTION:

To be distributed in accordance with DA Form 12-40, Operator's; Organizational and Direct Support Maintenance requirements for Trainer, Field Artillery, Kits, with Trainer M31.

CHANGE)
)
No.1)

HEADQUARTERS
DEPARTMENT OF THE ARMY
Washington, DC, 30 April 1982

OPERATOR, ORGANIZATIONAL, AND
DIRECT SUPPORT MAINTENANCE MANUAL
(INCLUDING REPAIR PARTS AND
SPECIAL TOOLS LIST)
FIELD ARTILLERY TRAINER KITS
(WITH FIELD ARTILLERY TRAINER M31)

TM 9-6920-361-13&P, 22 September 1976, is changed as follows:

The purpose of this change is to update configuration of adapter assemblies and to add the M198 Howitzer adapter assembly.

1. Remove old pages and insert new pages as indicated below. New or changed material is indicated by a vertical bar in the margin of the page. Added or revised illustrations are indicated by a vertical bar adjacent to the illustration identification number.

Remove pages

iii and iv
1-1 through 1-8
2-15 through 2-22
None
2-23 through 2-27/(2-28 blank)
3-1 through 3-4
4-1 through 4-8
None
A-1/(A-2 blank)
B-5 and B-6
C-3 through C-8
C-11 and C-12
C-23 and C-24
None
C-25 and C-26
None
C-27 and C-28
None
C-29 through C-32
INDEX 1 through INDEX 6

Insert pages

iii and iv
1-1 through 1-8
2-15 through 2-22
2-22.1 and 2-22.2
2-23 through 2-27/(2-28 blank)
3-1 through 3-4
4-1 through 4-8
4-8.1/4-8.2 blank)
A-1/(A-2 blank)
B-5 and B-6
C-3 through C8
C-11 and C-12
C-23 and C24
C-24.1 and C-24.2
C-25 and C26
C-26.1 and C-26.2
C-27 and C-28
C-28.1 and C-28.2
C-29 through C-32
INDEX 1 through INDEX 6

2. File this sheet in front of the publication for reference purposes.

By Order of the Secretary of the Army:

Official:

E. C. MEYER
General, United States Army
Chief of Staff

ROBERT M. JOYCE
Brigadier General, United States Army
The Adjutant General

Distribution:

To be distributed in accordance with DA Form 12-40, Organizational Maintenance requirements for Trainer, Field Artillery, 14.5-MM, M31.

OPERATOR, ORGANIZATIONAL, AND
DIRECT SUPPORT MAINTENANCE MANUAL
(INCLUDING REPAIR PARTS AND
SPECIAL TOOLS LIST)
FIELD ARTILLERY TRAINER KITS (WITH FIELD ARTILLERY TRAINER M31)

Current as of 7 June 1976

REPORTING OF ERRORS

You can help improve this manual by calling attention to errors and recommending improvements and by stating your reasons for the recommendations. Your letter or DA Form 2028 (recommended Changes to Publications and Blank Forms) should be mailed directly to Commander, US Army Armament Command, ATTN: DRSARMAS, Rock Island, IL 61201. A reply will be furnished directly to you. For your convenience, preaddressed DA Forms 2028 are included as final pages of this manual.

			Paragraphs	Pages
Chapter 1.	INTRODUCTION			
Section I.	General	1-1		1-1
Section II.	Description and data	1-4		1-1
Chapter 2.	OPERATING INSTRUCTIONS			
Section I.	Preparation for operation	2-1		2-1
Section II.	Service upon receipt of equipment	2-4		2-12
Section III.	Operation under usual conditions	2-11		2-23
Section IV.	Operation under unusual conditions	2-16		2-27
Chapter 3.	OPERATOR MAINTENANCE INSTRUCTIONS			
Section I.	Repair parts, special tools, and equipment	3-1		3-1
Section II.	Cleaning and lubrication instructions.....	3-3		3-1
Section III.	Preventive maintenance checks and services	3-5		3-3
Section IV.	Troubleshooting.....	3-7		3-4
Section V.	Maintenance instructions	3-8		3-4

*This manual supersedes TM 9-6920-221-13, 27 October 1966 including all changes.

	Paragraphs	Pages
Chapter 4. ORGANIZATIONAL MAINTENANCE INSTRUCTIONS		
Section I. Repair parts, special tools, and equipment	4-1	4-1
II. Preventive maintenance checks and services	4-3	4-1
III. Organizational maintenance instructions	4-5	4-2
Chapter 5. DIRECT SUPPORT MAINTENANCE INSTRUCTIONS		
Section I. Repair parts, special tools, and equipment	5-1	5-1
II. Troubleshooting	5-4	5-2
III. Inspections	5-5	5-3
Chapter 6. DIRECT SUPPORT MAINTENANCE REPAIR INSTRUCTIONS		
Section I. General maintenance	6-1	6-1
II. Maintenance of the bolt assembly	6-11	6-2
III. Maintenance of the mount assembly	6-15	6-3
IV. Maintenance of the tripod mount assembly	6-18	6-10
V. Maintenance of the telescope socket, holder, and support assemblies	6-21	6-12
VI. Final inspection	6-24	6-13
Chapter 7. AMMUNITION	7-1	7-1
Chapter 8. SHIPMENT AND LIMITED STORAGE	8-1	8-1
Appendix A. REFERENCES	A-1	A-1
Appendix B. MAINTENANCE ALLOCATION CHART	B-1	B-1
Appendix C. BASIC ISSUE ITEMS LIST AND ITEMS TROOP INSTALLED OR AUTHORIZED LIST AND ORGANIZATIONAL AND DIRECT SUPPORT MAINTENANCE REPAIR PARTS AND SPECIAL TOOLS LIST		
Section I. Introduction	C-1	C-1
II. Basic issue items list		C-5
III. Items troop installed or authorized		C-7
IV. Repair parts list		C-9
V. Special tools list		C-29
VI. National stock number and part number index		C-29
Index		Index-1

LIST OF ILLUSTRATIONS

Number	Title	Page
1-1	Mount and tripod assemblies	1-1
1-2	Mount assembly	1-2
1-3	Barrel assembly.....	1-3
1-4	Adapter assemblies	1-4
1-5	Lanyard ring assembly	1-5
1-6	Trainer ammunition	1-5
1-7	Basic issue items	1-7
2-1	Surface danger zone	2-1
2-2	For determining the exact surface danger area required (Charge 1 only)	2-1
2-3	Example of computed surface danger zone	2-3
2-4	Typical battery and battalion positions	2-3
2-5	Cinder block house	2-4
2-6	155-mm Propellant container target	2-4
2-7	175-mm Gun target model	2-5
2-8	Self-propelled antiaircraft vehicle target model	2-6
2-9	105-mm Howitzer target model	2-7
2-10	Armored personnel carrier target model	2-8
2-11	2 1/2 Ton target model	2-9
2-12	Example of a 14.5-mm range map	2-10
2-13	Labeling the special map	2-10
2-14	Special grid sheet map	2-11
2-15	Firingpoint marker	2-11
2-16	Permanent reference point	2-11
2-17	Temporary reference point	2-12
2-18	Operation of safety	2-25
2-19	Misfire device	2-26
3-1	Lubrication chart	3-2
4-1	Disassembly/assembly of breech bolt group	4-2
4-2	Disassembly/assembly of barrel assembly	4-3
4-3	Removal/installation of guide nut and screw from/to tripod rear leg	4-4
4-4	Removal/installation of telescope lock and tangent screws from/to telescope socket	4-4
4-5	Disassembly/assembly of adapter assembly PN 11578865 for M101A1	4-5
4-5A	Disassembly/assembly of adapter assembly PN 11578873 for M101A1	4-5
4-6	Disassembly/assembly of adapter assembly PN 11578750 for M102	4-6
4-6A	Disassembly/assembly of adapter assembly PN 11578967 for M102	4-6
4-7	Disassembly/assembly of adapter assembly PN 11578752 for M114 and M114A1	4-7
4-7A	Disassembly/assembly of adapter assembly PN 11578876 for M114AI	4-7
4-8	Disassembly/assembly of adapter assembly PN 11578780 for M109 series and M107/M110	4-8
4-8A	Disassembly/assembly of adapter assembly PN 11578870 for M109/M109A1/M110	4-8
4-8B	Disassembly/assembly of adapter assembly PN 11579605 for M198	4-8
4-9	Lanyard ring assembly - exploded view	4-8.1
5-1	Headspace gage	5-1
5-2	Checking headspace	5-1
6-1	Disassembly/assembly of breech bolt assembly	6-2

LIST OF ILLUSTRATIONS - Continued

Number	Title	Page
6-2	Removal/installation of L.H and R.H. trunnion caps	6-3
6-3	Replacing elevation group	6-4
6-4	Disassembly/assembly of mount group	6-5
6-5	Replacing telescope bracket assembly	6-6
6-6	Disassembly/assembly of elevating worm gear assembly	6-7
6-7	Disassembly/assembly of rapid traverse lever assembly	6-8
6-8	Disassembly/assembly of plunger locking assembly	6-8
6-9	Disassembly/assembly of fixed mount base assembly	6-9
6-10	Replacement of tripod locking lever group	6-10
6-11	Disassembly/assembly of tripod base assembly	6-10
6-12	Disassembly/assembly of tripod rear leg assembly	6-11
6-13	Disassembly/assembly of tripod front leg group	6-11
6-14	Disassembly/assembly of telescope socket assembly	6-12
6-15	Disassembly/assembly of telescope holder assembly	6-13
6-16	Disassembly/assembly of telescope support assembly - exploded view	6-13
C-1	Basic issue items	C-5
C-2	Basic issue items - continued.....	C-6
C-3	Items troop installed or authorized	C-7
C-4	Breech bolt group - exploded view	C-9
C-5	Barrel assembly - partial exploded view	C-10
C-6	Left and right trunnion cap groups - exploded view	C-11
C-7	Telescope bracket removed from mount	C-12
C-8	Mount assembly - partial exploded view	C-13
C-9	Mount assembly - partial exploded view	C-14
C-10	Plunger locking assembly - exploded view	C-15
C-11	Rapid traversing lever assembly - exploded view	C-15
C-12	Elevating worm gear bracket assembly - exploded view	C-16
C-13	Fixed mount base assembly - exploded view	C-17
C-14	Tripod locking lever group - exploded view	C-18
C-15	Tripod base assembly - exploded view	C-19
C-16	Tripod lower rear leg group - exploded view	C-20
C-17	Tripod lower front leg group - exploded view	C-21
C-18	Telescope socket assembly for M12 series telescope - exploded view	C-22
C-19	Telescope holder assembly for M113/M115 telescopes - exploded view	C-23
C-20	Telescope support assembly for M117 telescope - exploded view	C-23
C-21	Adapter assembly for M101A1 - exploded view	C-24
C-21A	Adapter assembly for M101A1 - optional manufacture	C-24.1
C-22	Adapter assembly for M102 - exploded view	C-24.2
C-22A	Adapter assembly for M102 - optional manufacture	C-25
C-23	Adapter assembly for M114 and M114A1 - exploded view	C-26
C-23A	Adapter assembly for M114A1 - optional manufacture	C-26.1
C-24	Adapter assembly for M109 series, and M107/M110 - exploded view	C-26.2
C-24A	Adapter assembly for M109/M 109A1/M110 - optional manufacture.....	C-27
C-24B	Adapter assembly for M198	C-28
C-25	Lanyard ring assembly, 14.5-mm gun - exploded view	C-28.1
C-26	Headspace gage	C-28.2

**CHAPTER 1
INTRODUCTION**

Section I. GENERAL

1-1. Scope. This technical manual contains instructions for the operations of the 14.5-mm field artillery trainer M31. It also contains instructions for the operation and maintenance of the trainer when it is used as an inbore subcaliber device on the various light, medium, and heavy weapons.

1-2. Field Artillery Trainer Kits. Kits included in this manual are as follows:

- a. Kit, Artillery Trainer for 105-mm How M102-11578584.
- b. Kit, Artillery Trainer for 155-mm How M109/M109A1-11578585.
- c. Kit, Artillery Trainer for 175-mm Gun M107 and 8-inch How M110-11578586.
- d. Kit, Artillery Trainer for 105-mm How M101A1-11578587.

- e. Kit, Artillery Trainer for 155-mm How M114A1 11578588.
- f. Kit, Artillery Trainer for 155-mm How M114A1/8-inch How M110 Composite Bn-11578589.
- g. Kit, Artillery Trainer for 105-mm How M101A1/155-mm How 114A1 Composite Bn-11578590.
- h. Kit, Artillery Trainer for United States Military Academy-USMA-11578591.
- i. Kit, Artillery Trainer for United States Army Infantry School-US AIS-11578592.
- j. Kit, Artillery Trainer for United States Army Field Artillery School-USAFAS-11578593.

1-3. Maintenance Forms and Records. Forms and records used for equipment maintenance will be prescribed in DA PAM 738-750, The Army Maintenance Management System.

Section II. DESCRIPTION AND DATA

1-4. Description.

a. *General.* The 14.5-mm field artillery trainer M31 consists of a bolt-action, single-shot, rifled barrel assembly which is mounted on a mount assembly and supported by a tripod assembly.

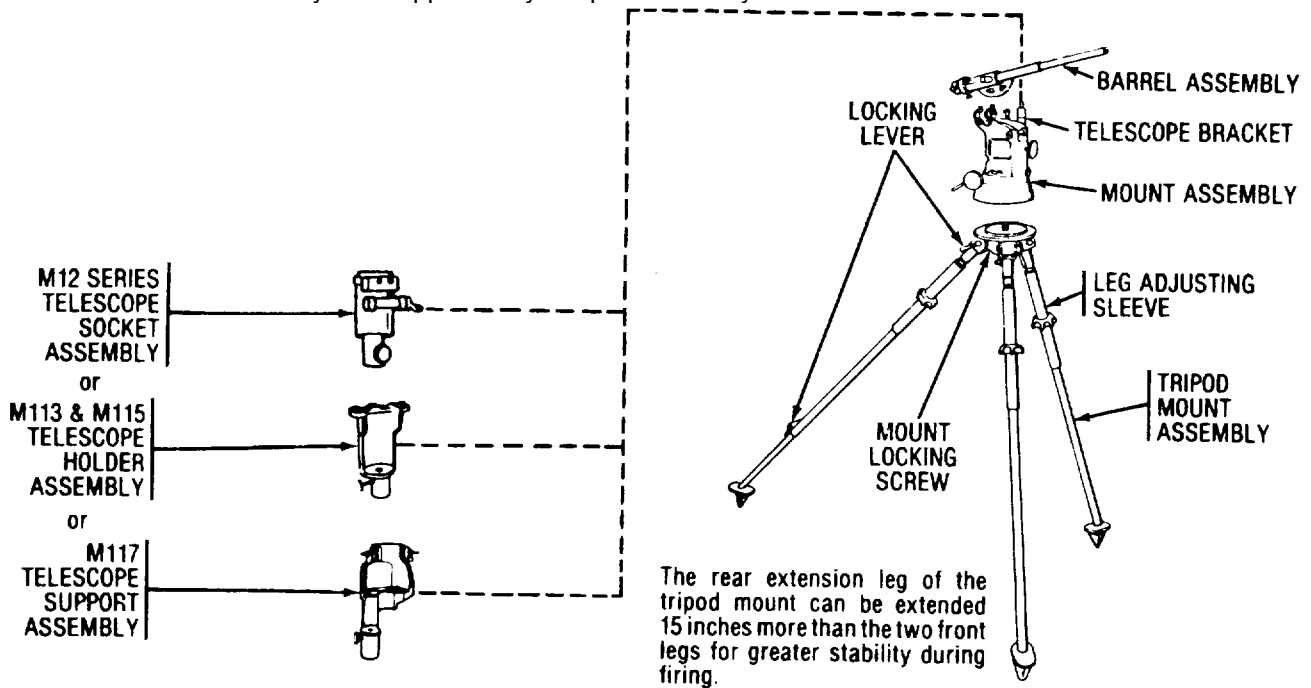

Figure 1-1. Mount and tripod assemblies.

b. *Mount Assembly.* The mount assembly consists of the rotating upper mount and the fixed base mount which contain the elevating and traversing gears. The

telescope bracket is attached to the left side of the upper mount. The identification plate is located on the right side of the upper mount.

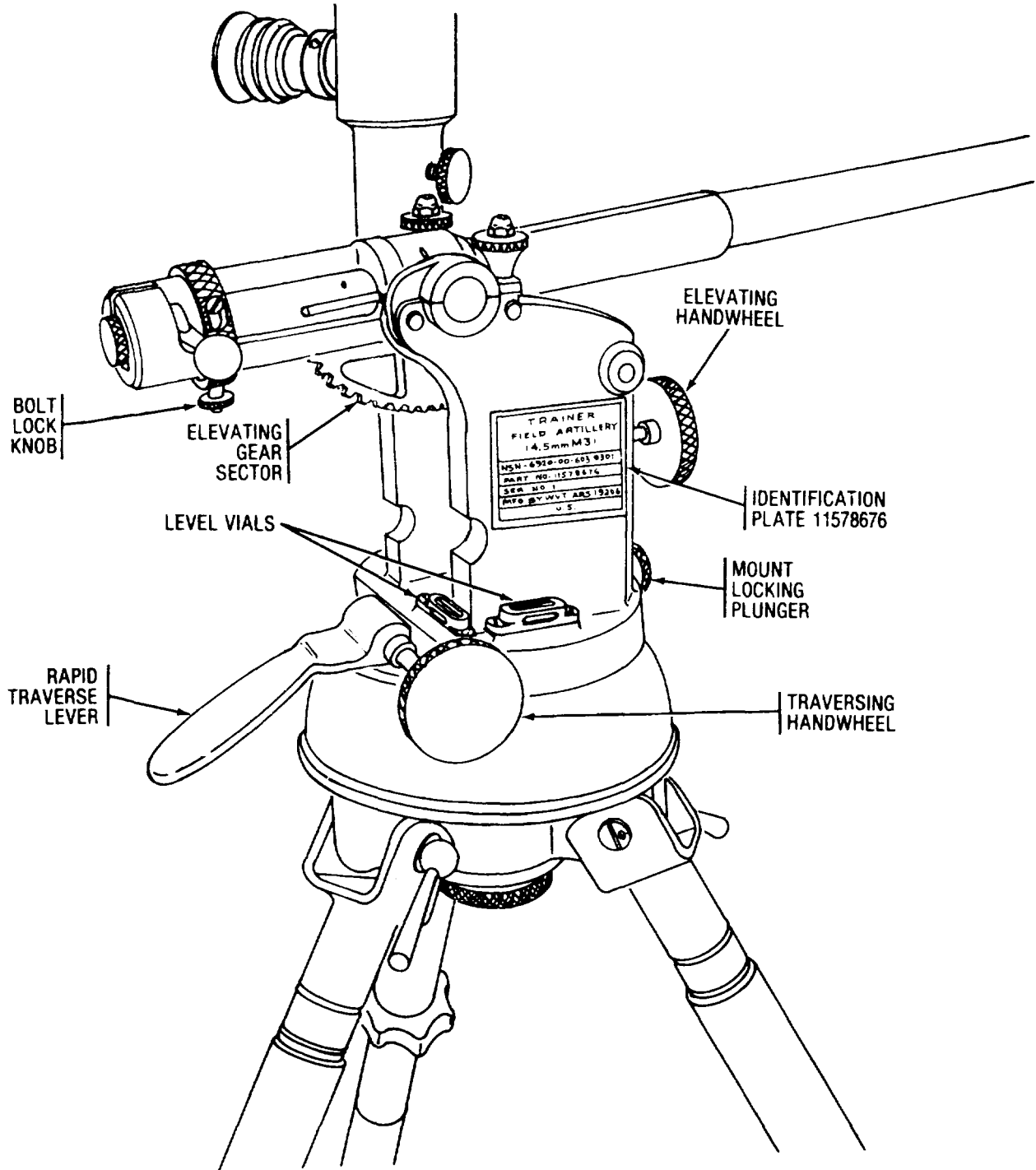

Figure 1-2. Mount assembly.

c. *Barrel Assembly.* The barrel assembly consists of a barrel trunnion and receiver assembly, a breech bolt group, a safety, and an elevating gear sector. The elevating gear sector is removed when the barrel

assembly is used as a subcaliber device. The top portion of the barrel has a flat machined surface to be used with a gunner's quadrant for laying the trainer for elevation.

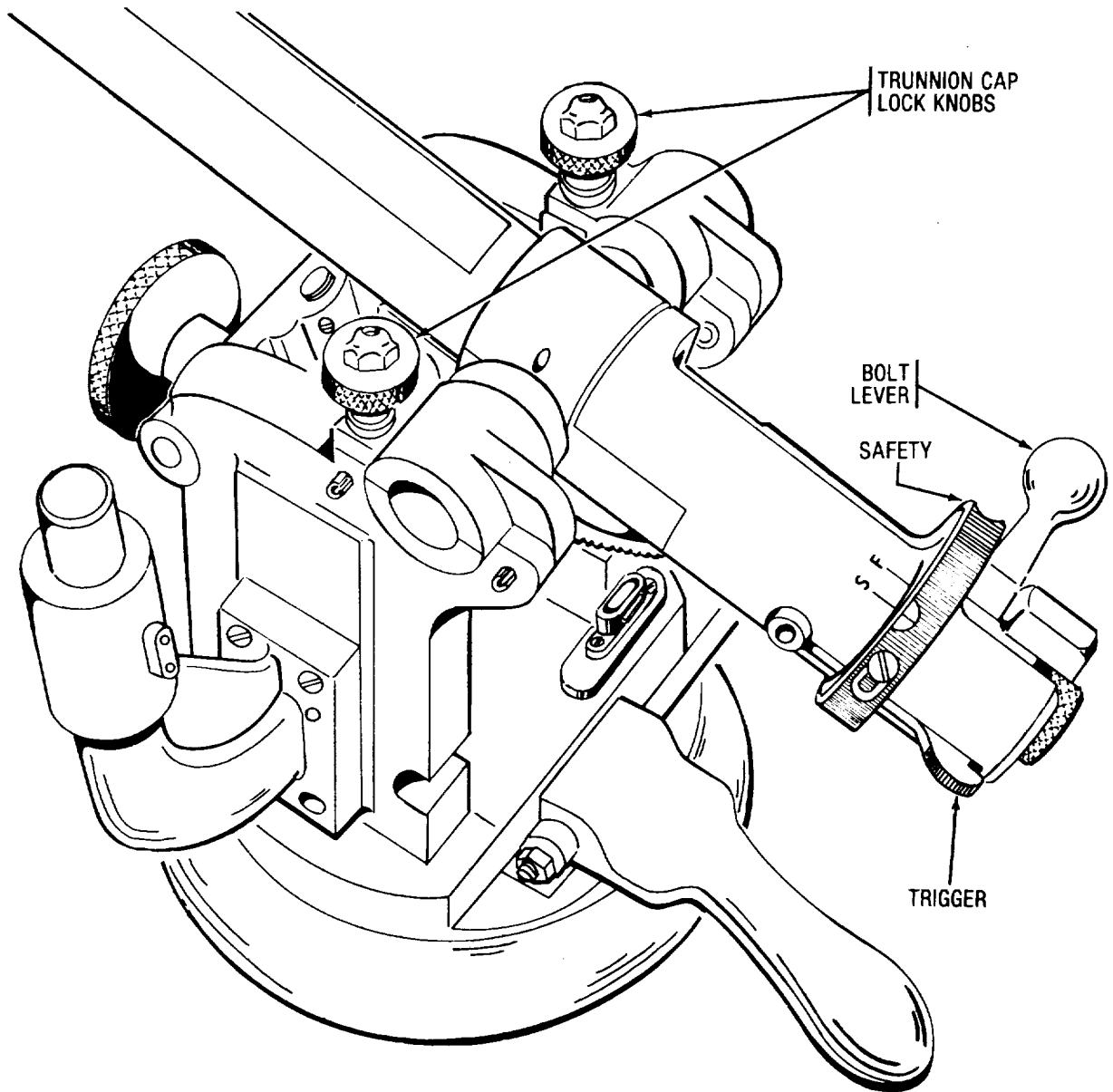
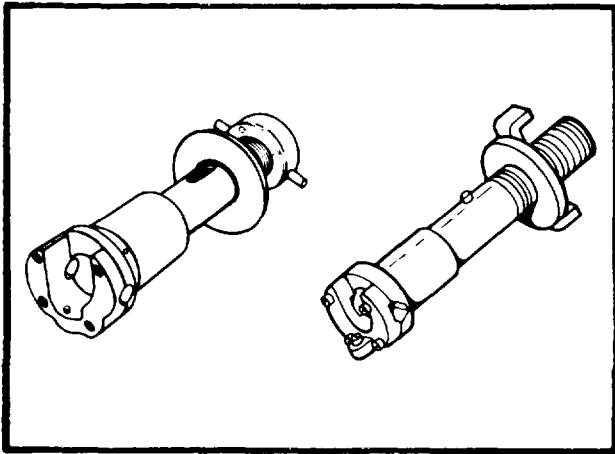

Figure 1-3. Barrel assembly.

d. Adapter Assemblies. The adapter assemblies are furnished in the various sizes and configurations necessary to mount the 14.5-mm cannon as an inbore subcaliber device in light, medium, and heavy artillery

weapons. A small quantity of adapters were made from optional method of manufacture drawings. They are slightly different in appearance, but are completely interchangeable.



ADAPTER ASSEMBLIES for M1091
M109A1/M115/M110 Howitzers and
M107 Gun

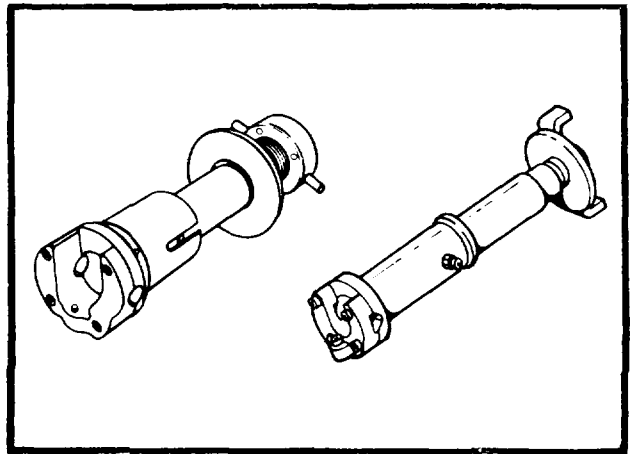

ADAPTER ASSEMBLIES for
M114A1 Howitzer

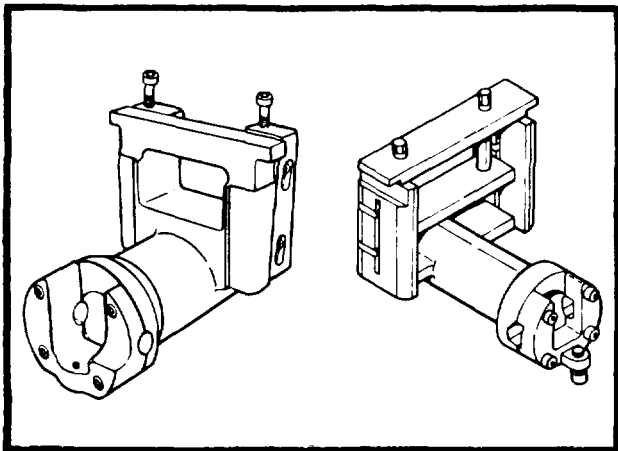

ADAPTER ASSEMBLIES for
M102 Howitzer

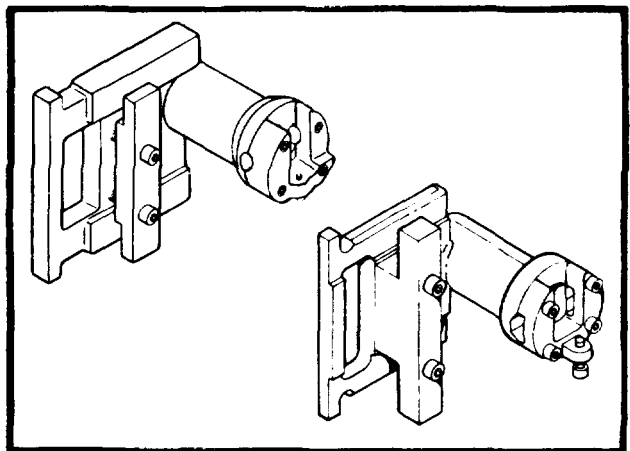

ADAPTER ASSEMBLIES for
M101A1 Howitzer

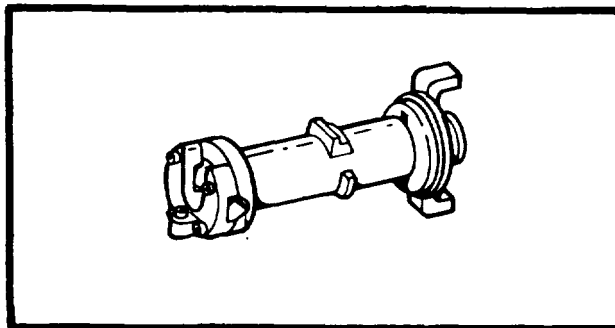

ADAPTER ASSEMBLY for
M198 Howitzer

Figure 1-4. Adapter assemblies.

e. *Lanyard Ring Assembly.* The lanyard ring assembly consists of a holder, lever, and lanyard which when placed on the barrel assembly provide an off-carriage means of firing the subcaliber device.

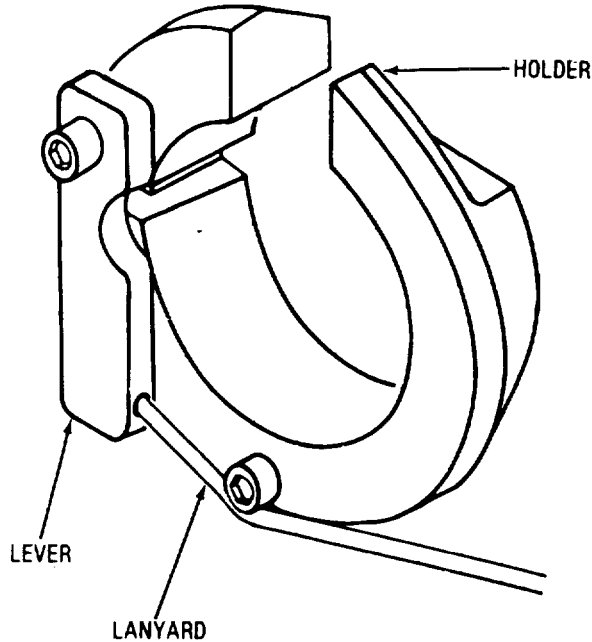

Figure 1-5. Lanyard ring assembly.

f. *Ammunition.* The trainer fires a projectile that ignites and produces an audible report, a puff of smoke visible for 1,000 meters in daylight, and a flash of light visible for several kilometers at night. Cartridges are available with a 3-second delay fuze (M181), a 6-second delay fuze (M182), or a point detonation fuze (M183).

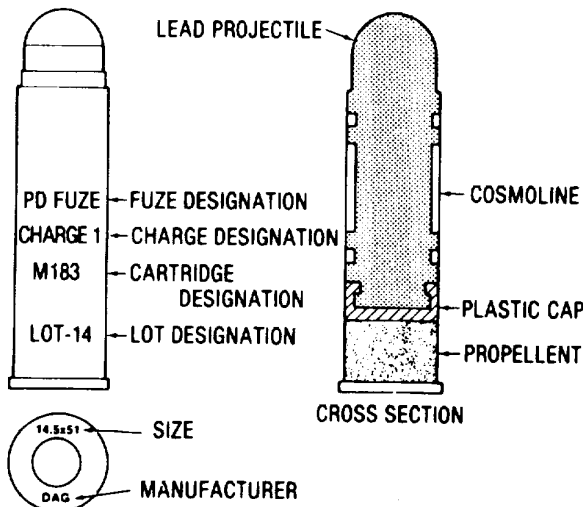

Figure 1-6. Trainer ammunition.

1-5. Differences Between Kits.

a. For list of available kits see para 1-2.

b. All kits contain certain items required to fire the M31 trainer either from the tripod or as a subcaliber device. These items are as follows:

- (1) Graphical firing tables.
- (2) Graphical site tables.
- (3) Tabular firing tables.
- (4) M18 FADAC tapes (revision 5).
- (5) TM 9-6920-361-13&P (6) Safety tongs.
- (7) Organizational repair parts.

c. Specific kits contain additional equipment as required for the types of weapons supported. Units equipped with the M12 series panoramic telescope will be issued a telescope socket assembly. Units equipped with the M113 or the M115 panoramic telescope will be issued a telescope holder assembly. Units equipped with the M117 panoramic telescope will be issued a telescope support assembly. Here is the breakdown on this equipment:

- (1) Kit for 105-mm How M102
 - (a) Two M31 trainers complete with telescope holder assembly.
 - (b) Six adapters for 105-mm How M102 with six lanyard ring assemblies.
 - (c) Four 14.5-mm barrels with cleaning kits.
- (2) Kit for 155-mm How M109/M109AI
 - (a) Two M31 trainers complete with telescope support assembly.
 - (b) Six adapters for the 155-mm How M109/M 109AI with six lanyard ring assemblies.
 - (c) Four 14.5-mm barrels with cleaning kits.
- (3) Kit for 175-mm Gun M107 and 8-inch How M110
 - (a) Two M31 trainers complete with telescope holder assembly.
 - (b) Four adapters for the 175-mm How M107 and 8-inch How M110 with four lanyard ring assemblies.
 - (c) Two 14.5-mm barrels with cleaning kits.
- (4) Kit for 105-mm How M101A1
 - (a) Two M31 trainers complete with telescope socket assembly.

- (b) Six adapters for the 105-mm How M101A1 with six lanyard ring assemblies.
- (c) Four 14.5-mm barrels with cleaning kits.

(5) Kit for 155-mm How M114A1.

- (a) Two M31 trainers complete with telescope socket assembly.
- (b) Six adapters for the 155-mm How M114A1 with six lanyard ring assemblies.
- (c) Four 14.5-mm barrels with cleaning kits.

(6) Kit for 155-mm How M114A1/8-inch How M10 Composite Bn.

- (a) Two M31 trainers with one telescope socket assembly and one telescope holder assembly.
- (b) Six adapters for the 155-mm How M114A1 and four adapters for the 8-inch How M110, with six lanyard ring assemblies.
- (c) Four 14.5-mm barrels with cleaning kits.

(7) Kit for 105-mm How M101A1/155-mm How M114A1 Composite Bn.

- (a) Two M31 trainers complete-with telescope socket assembly.
- (b) Six adapters for the 105-mm How M101A1 and six adapters for the 155-mm How M114A1, with twelve lanyard ring assemblies.
- (c) Four 14.5-mm barrels with cleaning kits.

(8) Kit for United States Military Academy Sixteen M31 Trainers complete with telescope socket assembly.

(9) Kit for United States Army Infantry School Seven M31 trainers complete with telescope socket assembly.

(10) Kit for United States Army Field Artillery School.

- (a) Twelve M31 trainers complete with telescope holder assembly.
- (b) Twelve adapters for the 105-mm How M102 with twelve lanyard ring assemblies.
- (c) Twelve 14.5-mm barrels with cleaning kits.

(11) Kit for 155-mm How M198

- (a) Two M31 trainers complete with telescope holder assembly.
- (b) Six adapters for the 155-mm How M198 with six lanyard ring assemblies.
- (c) Four 14.5-mm barrels with cleaning kits.

(12) Kit for 105-mm How M101A1/ 155-mm How M198 Composite Bn.

- (a) Two M31 trainers with one telescope socket assembly and one telescope holder assembly.
- (b) Six adapters for the 105-mm How M101A1 and six adapters for the 155-mm How M198, with twelve lanyard ring assemblies.
- (c) Four 14.5-mm barrels with cleaning kits.

(13) Kit for 155-mm How M198/8-inch How M110 Composite Bn.

- (a) Two M31 trainers with one telescope holder assembly and one telescope socket assembly.
- (b) Six adapters for the 155-mm How M198 and four adapters for the 8-inch How M110, with six lanyard ring assemblies.
- (c) Four 14.5-mm barrels with cleaning kits.

1-6. Tabulated Data

a. General.

Barrel	Rifled portion 13-1/4 inches long, uniform right hand twist, one turn in 8.5 calibers
Breech	Bolt action with safety Firing mechanism
Firing mechanism	Trigger located at left rear of breech
Elevating limits	Minus 52 mils and plus 1,617 mils
Loading limits	Minus 52 mils and plus 1,070 mils
Traverse	6,400 mils
Mils per turn of handwheel:	
Elevating	52 mils
Traversing	66 mils

b. Ammunition (Fixed Round

14.5-mm Cartridge).	
M181-Charge 1 (1305A365).	3-second delay fuze
M182-Charge 1 (1305A366).	6-second delay fuze
M183-Charge 1 (1305A367).	Point detonating fuze
Muzzle velocity (all cartridges)	100 meters per second

c. *Weights.*

Tripod mount assembly	46 pounds
Mount assembly (rotating and fixed base)	47 pounds
Barrel assembly	8.5 pounds
Telescope socket assembly for M12 Series panoramic telescope	4 pounds
Telescope holder assembly for M113 or M115 panoramic telescope	6 pounds
Telescope support assembly for M117 panoramic telescope	7 pounds
Adapter for 105-mm How M101A1	27 pounds
Adapter for 105- mm How M102	29 pounds

Adapter for 155-mm HowM114A1	21 pounds
Adapter for M109/M109A1/ M107/M110vehicles.	24 pounds
Adapter for 155-mm How M198	15 pounds

d. *Dimensions.*

Recommended emplacement height on tripod	64 inches
Spread of front legs emplaced	55 inches
Length of front legs	45 inches
Length of extended rear leg	60 inches
Length of barrel	15.75 inches
Shipping and storage chest	61 x 12-3/4 x 11-7/8

1-7. **Basic Issue Items**

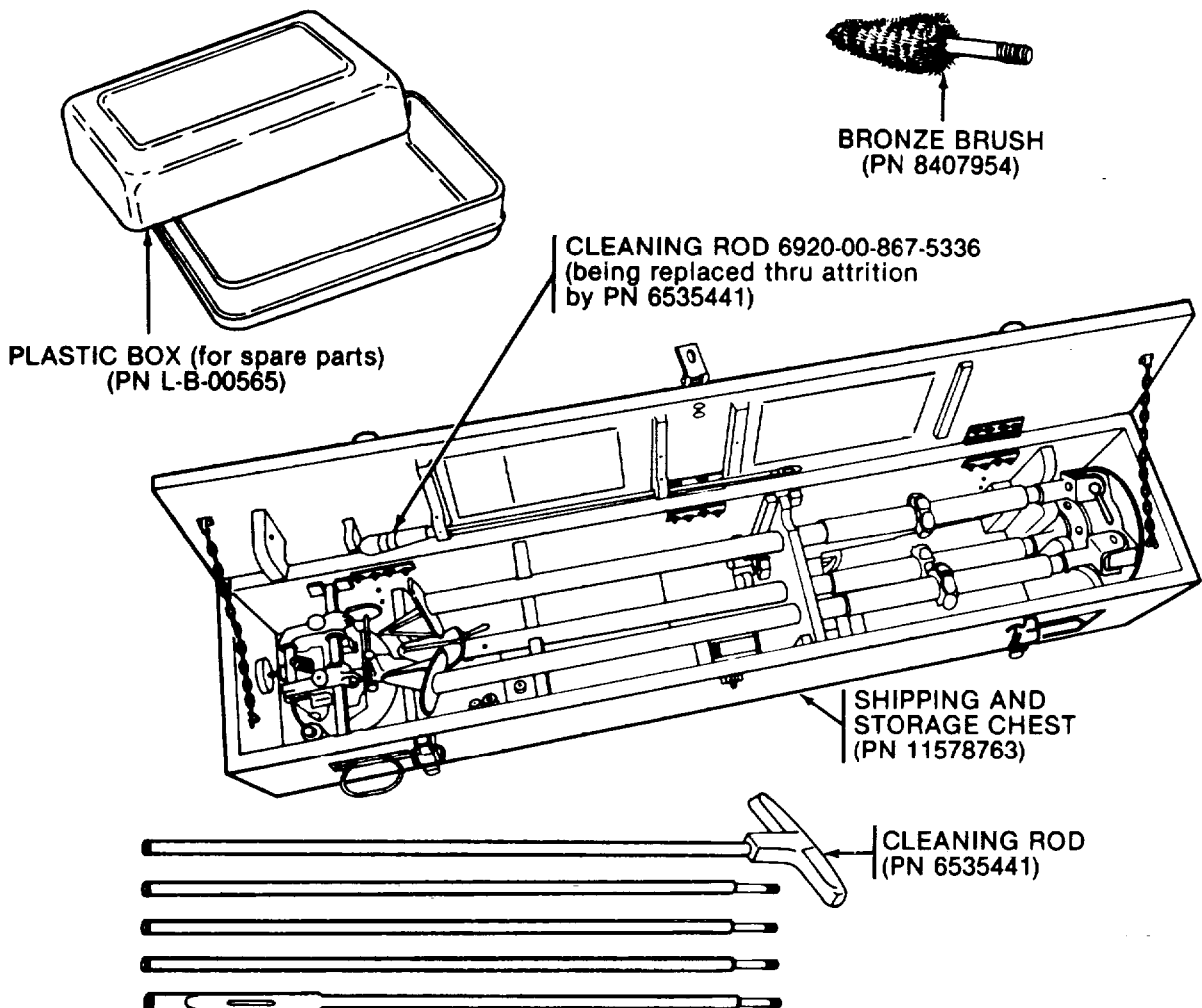
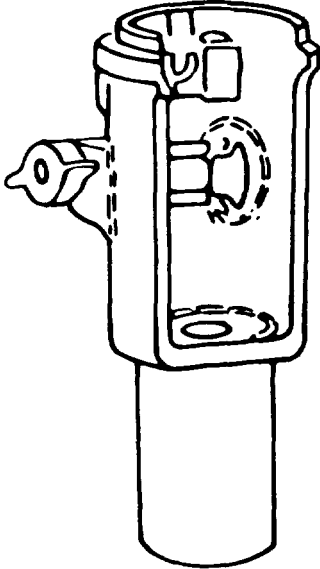
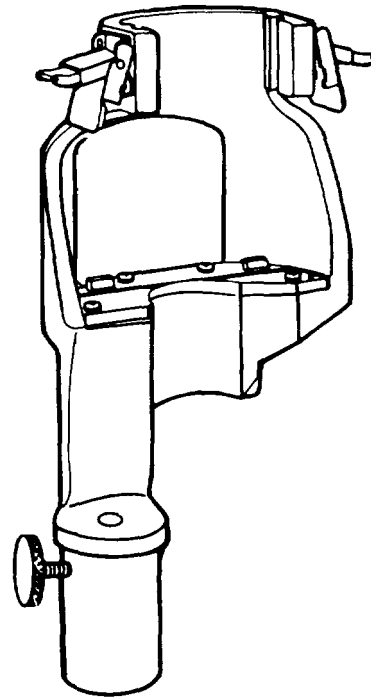

Figure 1-7. Basic issue items.

1-7. Basic Issue Items - Continued



TELESCOPE SOCKET (PN 11578700)
For M12 Series Panoramic Telescope



TELESCOPE SUPPORT ASSEMBLY (PN 11728907)
For M117 Panoramic Telescope

ARR 81-1842

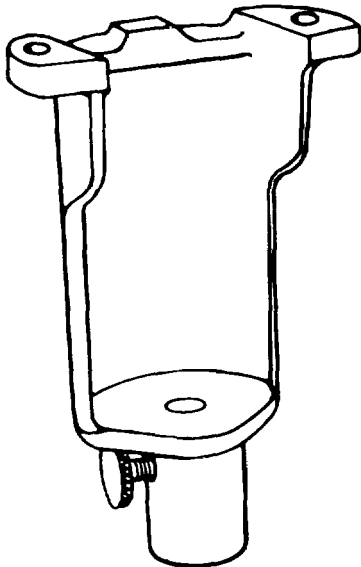

TELESCOPE HOLDER ASSEMBLY (PN 11727520)
For M113/M115 Panoramic Telescope

1-8. Items Troop Installed or Authorized. Troop installed items are listed in section III of appendix C, and are illustrated in paragraphs 1-4d and e.

1-9. Consumable and Expendable Items.

GAA	5 lbs.	9150-00-190-0904
SD	1 gal.	6850-00-281-1985
Rags	5 lbs.	7920-00-234-8465
Enamel	1 gal.	8010-00-297-2116
Brush	2	7920-00-205-2401
Swabs	1,000	1005-00-288-3565
CLP	1 pt./w/ trigger spray	9150-01-054-6433
	4-oz. bt.	9150-01-079-6124

Figure 1-7. Basic issue items--continued.

CHAPTER 2
OPERATING INSTRUCTIONS

Section I. PREPARATION FOR OPERATION

2-1. General. The amount of time spent in preparation greatly determines the amount of benefit the unit will derive from training with the M31. Certain preparations must be made in order to get maximum benefit from the equipment in the training kits. Your unit must construct a miniature range, develop a special map, and instruct personnel on the use of the equipment. The more thorough the preparation, the better your training will be.

2-2. Constructing a Firing Range.

a. *Select a Range Site.* The first step is the selection of a range site. Commanders may authorize M31 trainer firing on permanent firing ranges or in other approved training areas--when such firing is conducted in accordance with safety requirements which will be discussed later. The terrain should be slightly rolling. Otherwise, rounds can be lost in deep ditches, behind large mounds, or in exceptionally tall (higher than six inches) grass or weeds.

b. *Types of Ranges.* Permanent, semipermanent, and temporary ranges can be constructed. Their characteristics are:

(1) *Permanent range.* A permanent range is one which is used only for 14.5-mm firing. The targets, reference points, firing point markers, observation posts, and other manmade objects are permanently emplaced and marked. Most military posts have sufficient area to accommodate one or more such ranges.

(2) *Semipermanent.* A semipermanent range is one which must be shared with other training activities or operations, such as known distance rifle range, drill field or temporary landing field. The targets, reference points, etc., must be removed after use and all reference stakes which mark the location of these items must be at or below ground level. The unit can use the range on a scheduled basis.

(3) *Temporary range.* A temporary range is one which is used by the unit on a one-time basis (e.g., one day or one weekend) and is normally on private property such as a meadow, field, or pasture.

c. Surface Danger Zone.

(1) The dimensions of the surface danger zone are dependent on the nature of the firing and the type of surface conditions present within the surface danger zone.

(2) Figure 2-1 represents the "worst case" for soft or medium soil conditions. If the area for the proposed surface danger zone is limited, the exact dimensions for all surface conditions can be determined by using table 2-1 in conjunction with figure 2-2. For example, if the maximum range to be fired was 500 meters, and the impact area was composed of soft soil, the surface danger area would extend 580 meters downrange and the lateral buffer zone would be 25 meters outside of the right and left deflection limits as shown in figure 2-3.

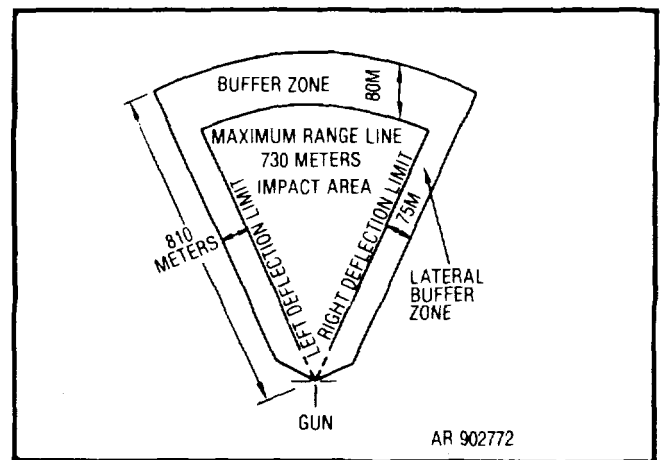

Figure 2-1. Surface danger zone

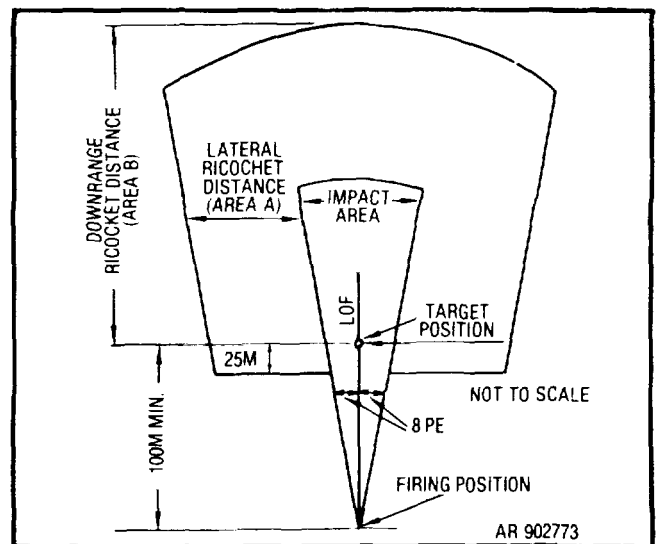

Figure 2-2. For determining the exact surface danger area required (Charge 1 only)

Table 2-1. Required Surface Danger Zone Dimensions (Charge 1 Only).

Impact Area Condition	Range to Target	Maximum Ricochet Distance (Charge 1 Only)	
		Downrange (Area B)	Lateral (Area A)
Soft soil (loose and essentially rock free for the top six (inches))	100	470	75
	150	420	75
	200	375	75
	250	330	75
	300	305	75
	350	290	75
	400	285	75
	450	80	25
	500	80	25
	550	80	25
	600	80	25
	650	80	25
	700	80	25
	730	80	25
Medium soil (essentially rock free and of medium hardness)	100	490	75
	150	455	75
	200	410	75
	250	370	75
	300	355	75
	350	350	75
	400	350	75
	450	80	25
	500	80	25
	550	80	25
	600	80	25
	650	80	25
	700	80	25
	730	80	25
Macadam/Concrete (also hard soil with rock present)	100	1345	120
	150	1310	135
	200	1265	145
	250	1215	195
	300	1165	205
	350	1120	245
	400	1070	250
	450	1020	285
	500	965	310
	550	910	310
	600	855	325
	650	790	315
	700	710	310
	730	590	280

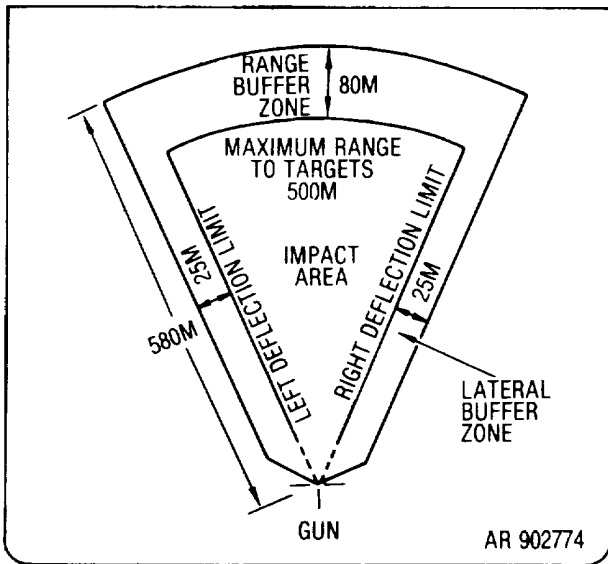

Figure 2-3. Example of computed surface danger zone

(3) Entering the surface danger zone is prohibited unless positive protection is provided against ricochet and projectile impact. When it is necessary to position personnel within the surface danger zone, the officer in charge or safety officer will insure adequate protection is provided. Minimum thicknesses of material required to protect personnel are:

- (a) Wood--2 inches.
- (b) Aluminum--0.04 inches.
- (c) Sandbags--3 (18 inches total thickness).
- (d) Sand or soil backed by wood or metal for support--14 inches.

d. Federal Aviation Administration (FAA) Notification.

(1) Since the 14.5-mm trainer is used to conduct indirect fire and is classified as field artillery, the airspace in the firing area represents a hazard to low flying aircraft. When the 14.5-mm range is established at a location other than a military reservation (e.g., a large plot of farmland) the selected site must be classified as a controlled firing area by the FAA.

(2) A controlled firing area is an area in which activities are conducted which, if not conducted in a controlled environment, could be hazardous to nonparticipating aircraft in flight. Further information on controlled firing areas, and instructions for submitting a request, are found in AR 95-50. The unit should contact the appropriate Department of the Army Regional

Representative (AR 95-50) for TM 9-6920361-13&P assistance when preparing a request. Normally 90 days is the minimum time required for approval or disapproval of a request.

(3) Military reservations normally are classified as restricted areas for nonmilitary aircraft. The site for the range on a military reservation can thus be approved by the post range control personnel.

e. Range Construction.

(1) After the site for the range has been selected, it should be examined by ground reconnaissance to determine the best position for observation posts (OP) and firing positions (FP). It is very important that these positions be selected so that the angle T is kept as small as possible. In addition, the FPs should be almost on line with the OPs so that your OPs do not interfere with the lateral safety limits.

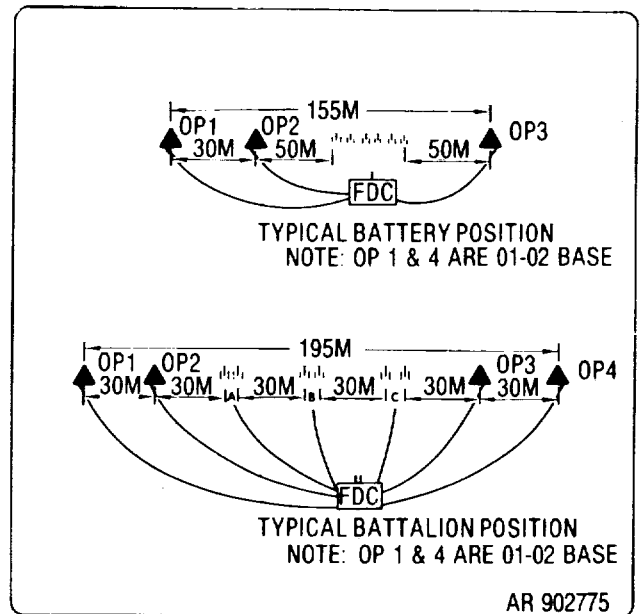

Figure 2-4. Typical battery and battalion positions

(2) Figure 24 is a sketch of typical battery and battalion position areas. If the area offers good observation from three or four sides, select several FP; OP combinations to permit the unit to move from one position to another. The terrain should be evaluated carefully in an attempt to locate the firing positions in accordance with good position selection criteria.

(3) A target area plan should be devised by the project officer and approved by the unit commander. While the plan need not be to scale, it should show the relative location of houses, roads and other manmade objects to be constructed in the area.

(4) A good plan will save many hours in organizing work details and will allow several projects to be accomplished simultaneously. For example, if the plan shows four roads in the target area, and the project officer has four work crews, he need only to stake the start point, road junctions, crossroads, and terminal point. The work crew will then be able to follow a simple sketch with minimum supervision from the project officer.

(5) As the roads are constructed, buildings can be erected to represent farmhouses, villages and towns. Manmade objects such as buildings and towns are represented on the observer's map by normal military symbols.

(6) Two-way roads should be about 40-50 inches wide. For permanent or semipermanent ranges, the roads can be made of asphalt, gravel, concrete, or any other material that would indicate a road. A scraper can be used to scrape out a road; however, the road may lose its identity when grass and weeds grow in the cleared area.

(7) The observer can best use buildings, water towers or other permanent terrain features to relate to targets. By using imagination and ingenuity, realistic reference points can be constructed. All targets should be three dimensional to insure accurate representation of the target from any viewing angle.

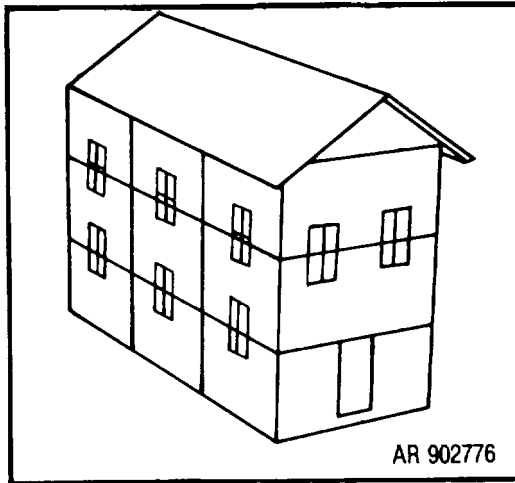

Figure 2-5. Cinder block house

Some target examples are:

(a) Simple buildings (as shown in figure 2-5) can be constructed in minutes by one man stacking nine cinder blocks three wide and three high. Doors and windows can be painted on the blocks. Ammunition boxes or other salvage lumber can be used to construct A-frame type roofs to be placed on top of the cinder blocks. Several houses of this type positioned in the same area can be used to represent a village.

(b) A 55-gallon drum placed on end and painted aluminum or with red and white squares can be used to represent a water tower.

(c) By placing a cross on the roof of one of the buildings, it will look like a church to the observer. The church can also be shown on the observer's map by the appropriate military symbol.

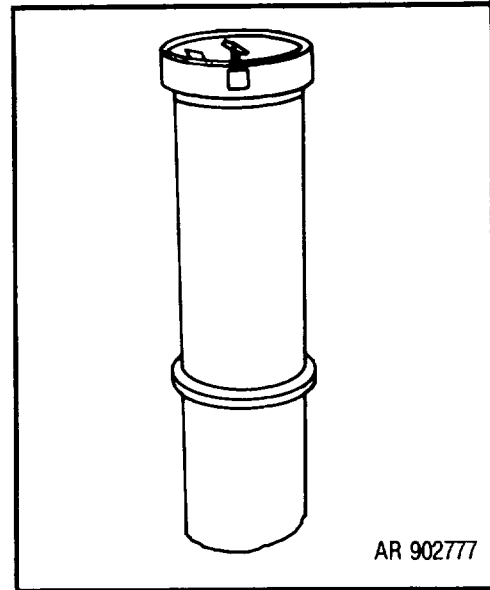
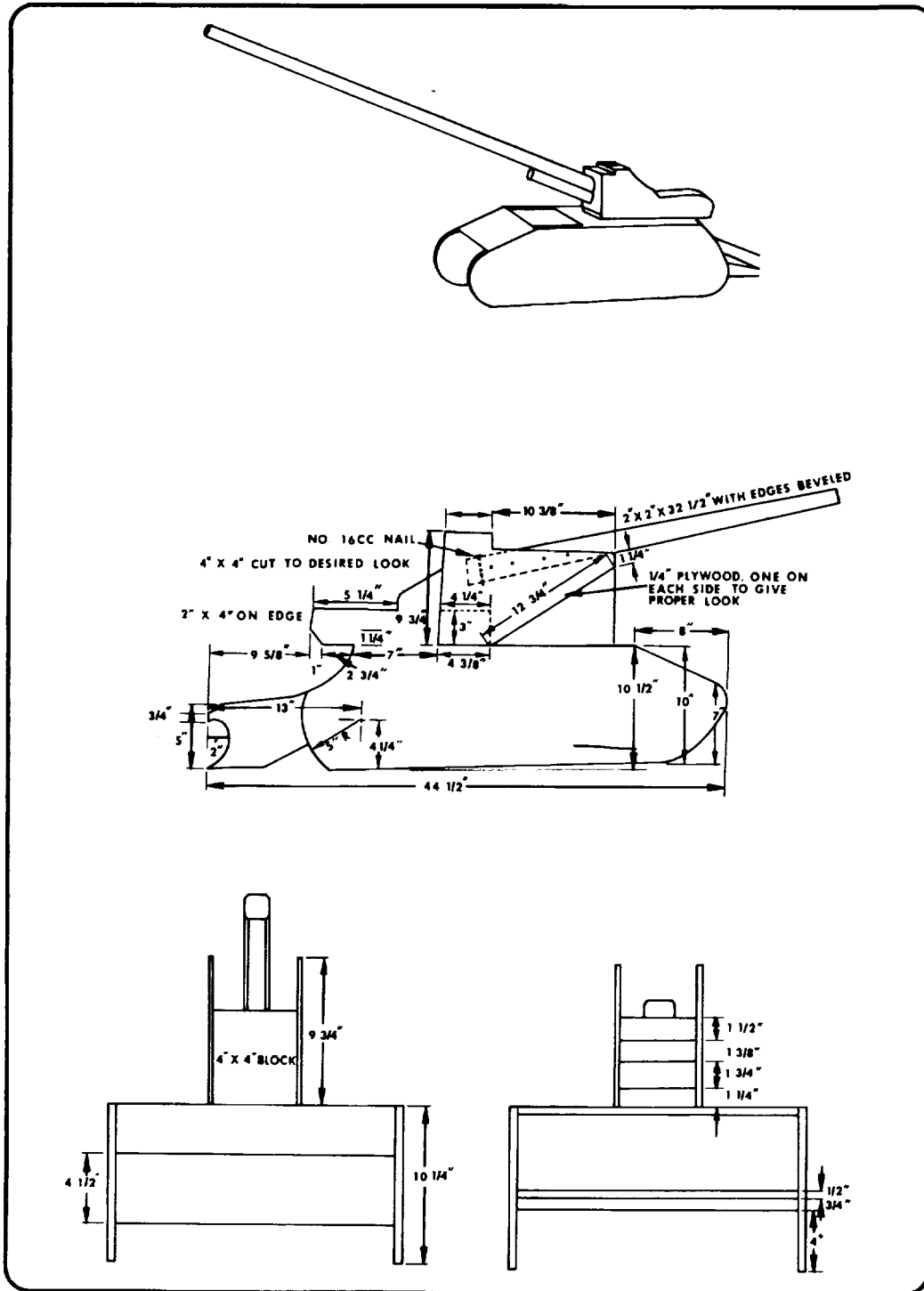

Figure 2-6. 155-mm Propellant container target

(8) Full scale artillery ranges use car bodies, salvaged tanks, trucks, etc., for targets. Targets for the 14.5-mm range could be cardboard boxes, old automobile tires, ammunition boxes, propellant containers, etc. A 155-mm propellant container makes a good adjusting point (fig. 2-6). Half the metal container is painted and the unpainted portion is buried in the ground. Use of several such containers, painted in different colors, offers a good variety of adjusting points.

(9) However, more realism is created if the unit builds trucks, tanks, self-propelled artillery weapons, and other type military vehicles which can be placed in the impact area and identified to the observer as a target for him to engage. For example, the officer in charge of firing could identify a target near an APC as: TEN PERSONNEL IN VICINITY OF DISABLED APC. THE APC IS THE ADJUSTING POINT.

(10) Here are five examples (fig. 2-7 thru 2-11) of types of targets used on permanent, Semipermanent or temporary ranges. The targets are all made from plywood and scrap lumber. Targets should be accurately located by survey and secured to a stake at that location.



AR 902778

Figure 2-7. 175-mm Gun target model

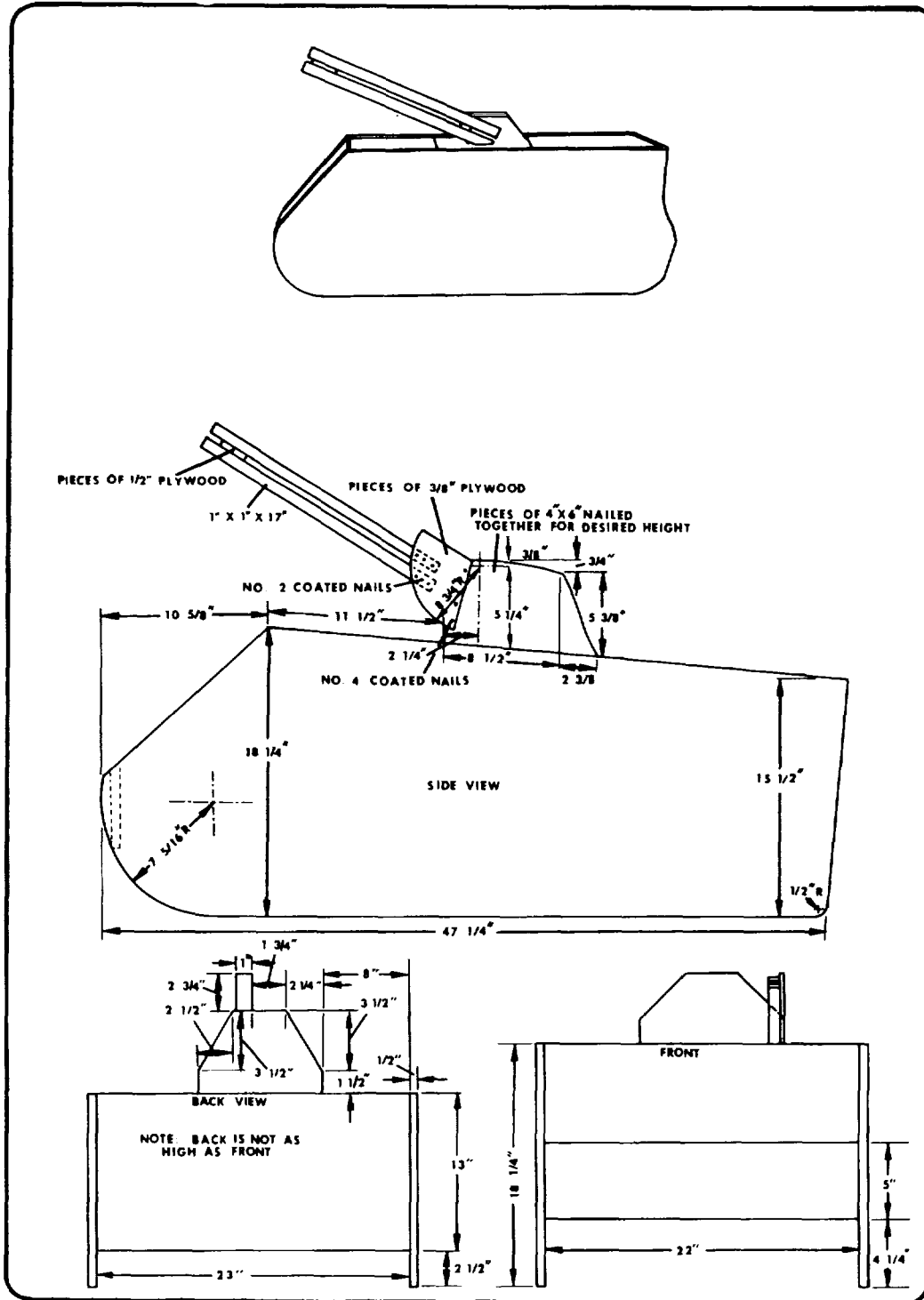

AR 902779

Figure 2-8. Self-propelled anti-aircraft vehicle target model

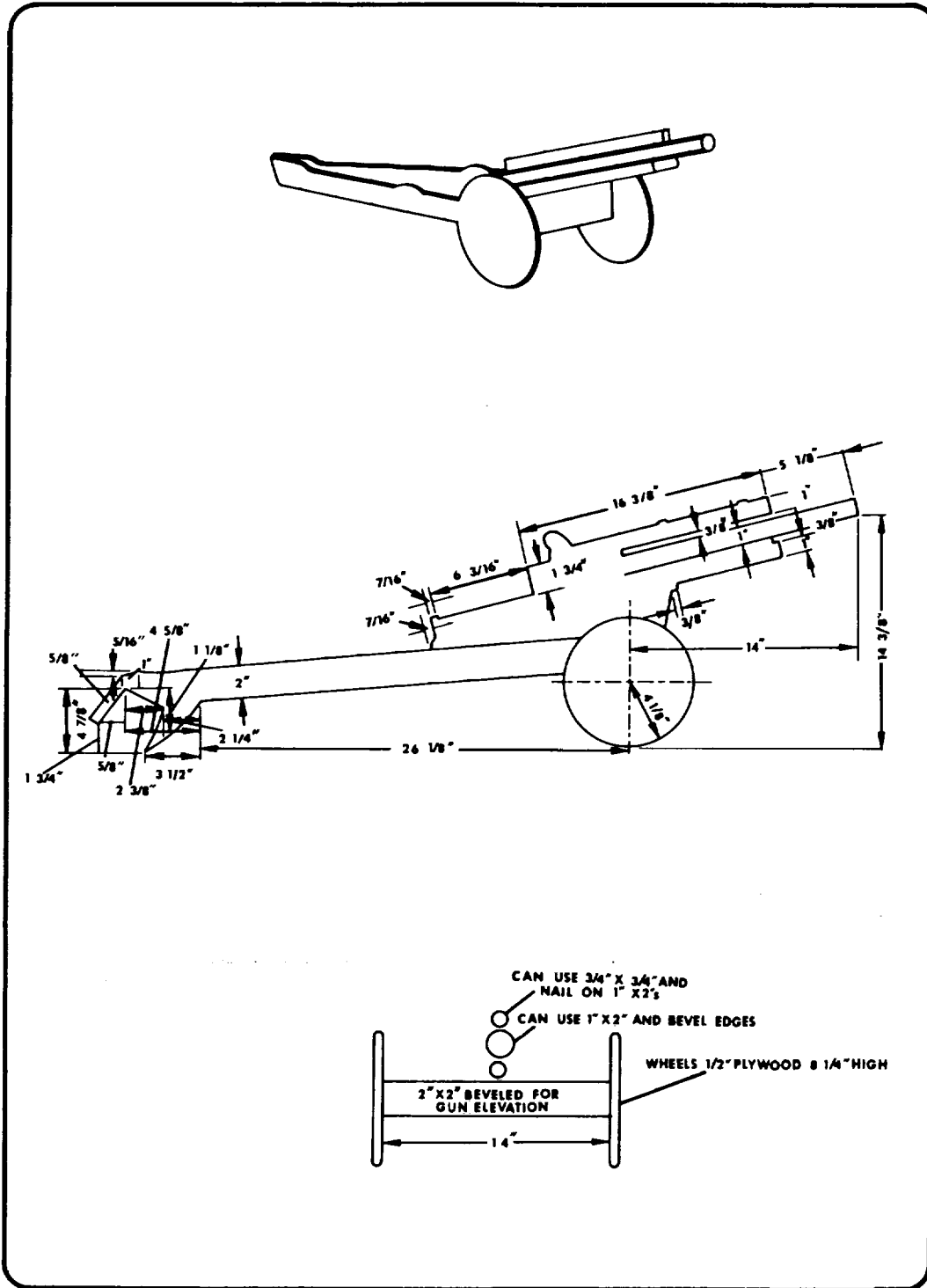

AR 902780

Figure 2-9. 105-mm Howitzer target model

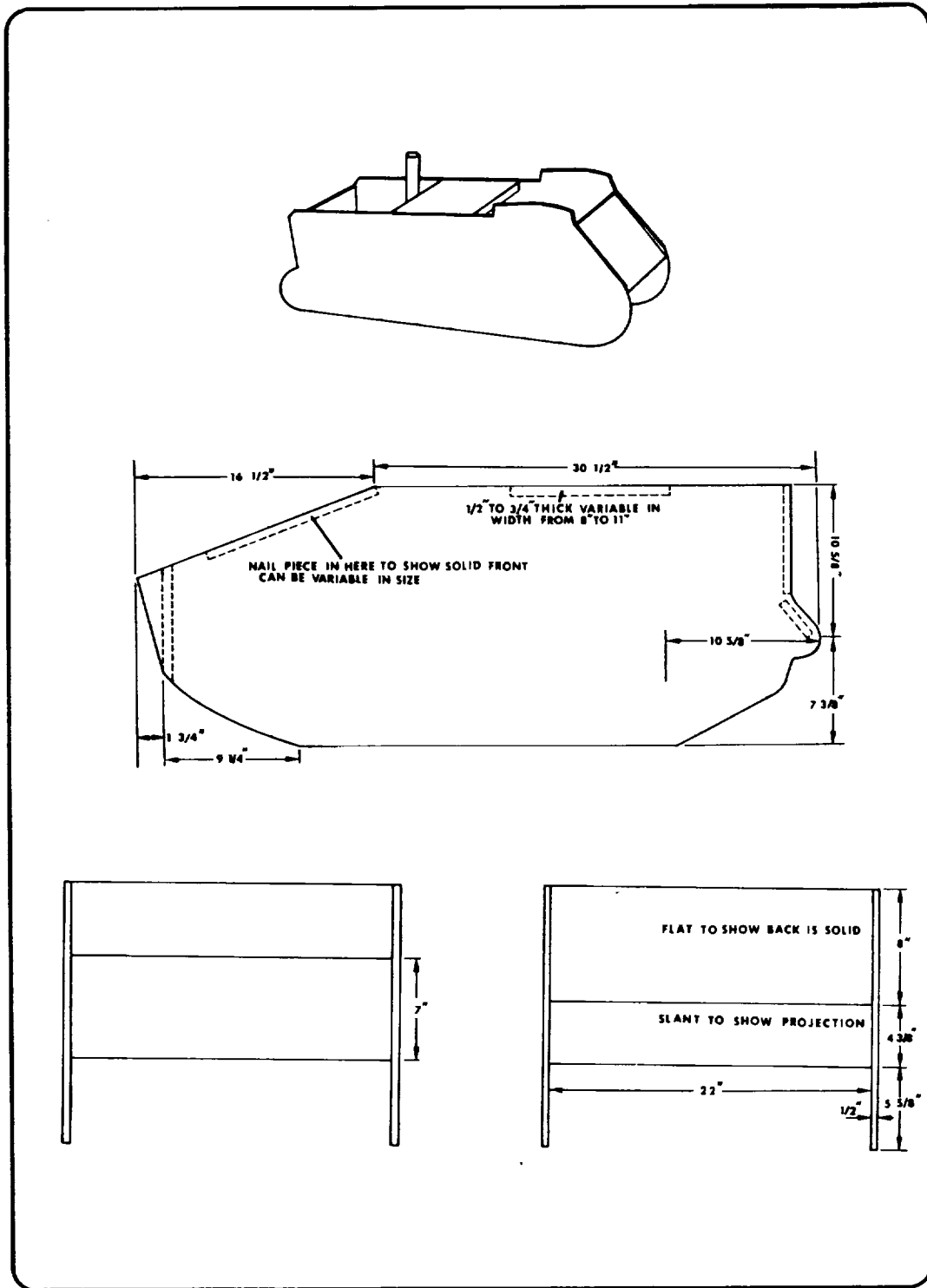

AR 902781

Figure 2-10. Armored personnel carrier target model

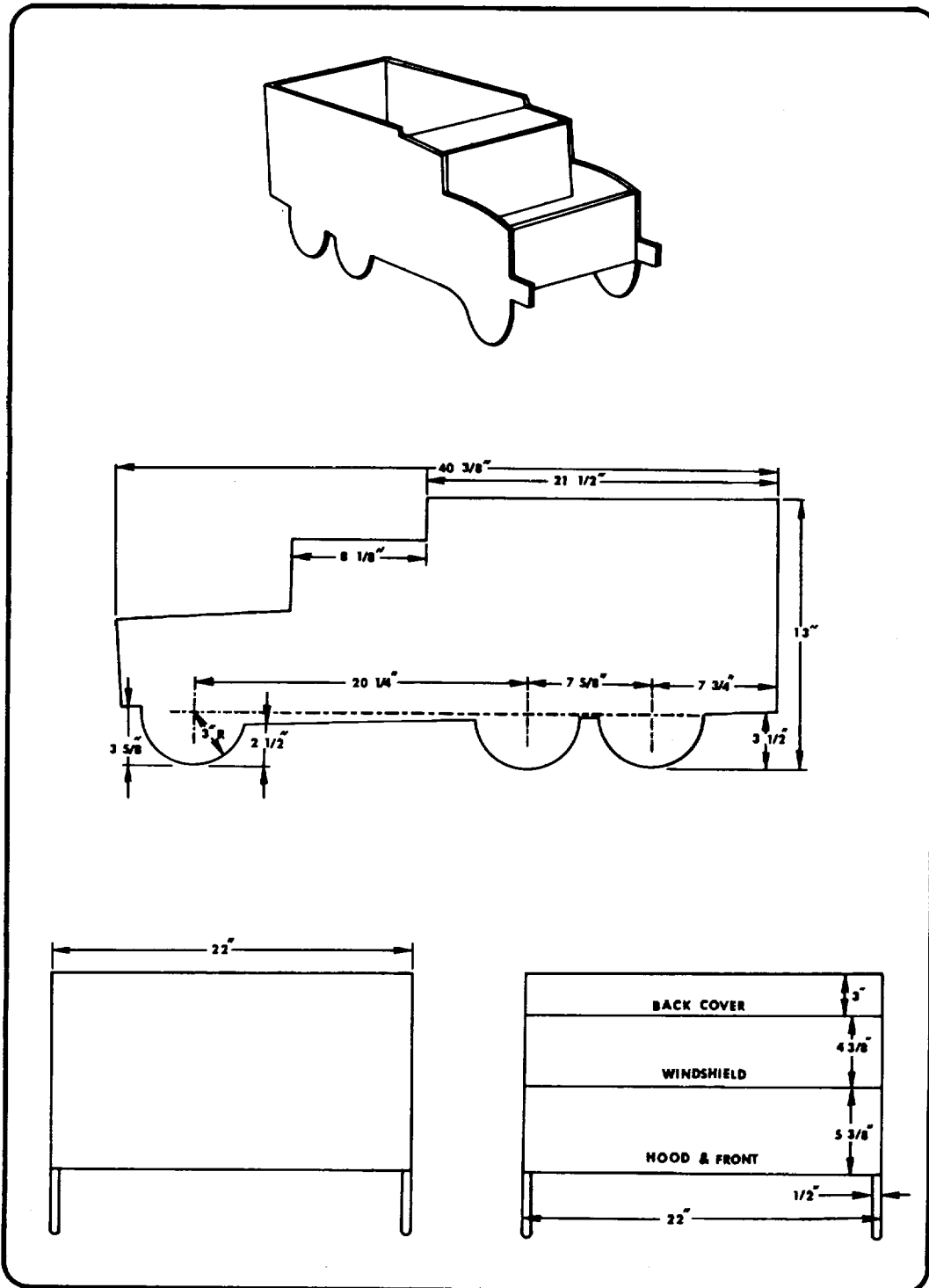

AR 902782

Figure 2-11. 2 1/2 Ton target model

2-3. Constructing a Map for the Range.

a. Maps for Permanent and Semipermanent Ranges.

(1) For permanent and semipermanent ranges a 1:5,000 scale map of the impact area should be constructed. Most training aids centers can enlarge a portion of a map in order to create the required scale. Figure 2-12 shows a type 1:5,000 scale map of 800 meters by 1,100 meters section of a range at Fort Sill, Okla. The map shows the contour lines and terrain features shown on the original map.

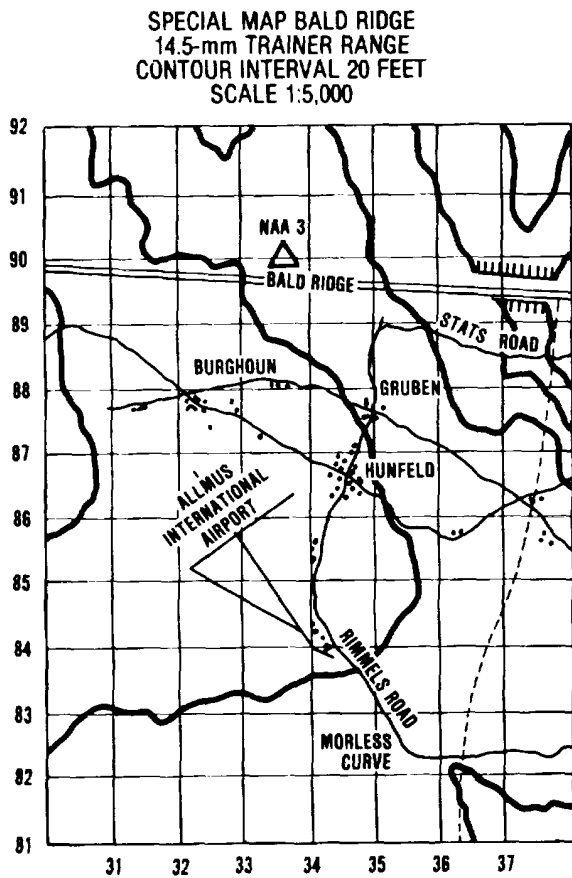

AR 90271

Figure 2-12. Example of a 14.5-mm range map

(2) After the roads, buildings, and other constructed terrain features (such as small mounds or orchards) have been positioned and accurately located by survey, they are included on the map. The map need not be in color if the terrain is fairly level and there are few contour lines. However, there should be sufficient information on buildings, roads, orchards, etc., to permit the observer to locate targets in relation to a known point that he can identify on the ground and on the map.

(3) The grid lines on the special map are scaled to 100 meters (1,000 decimeters) apart so the observer can use the normal observed fire (OF) fan and the coordinate scale that he would use with a 1:50,000 map.

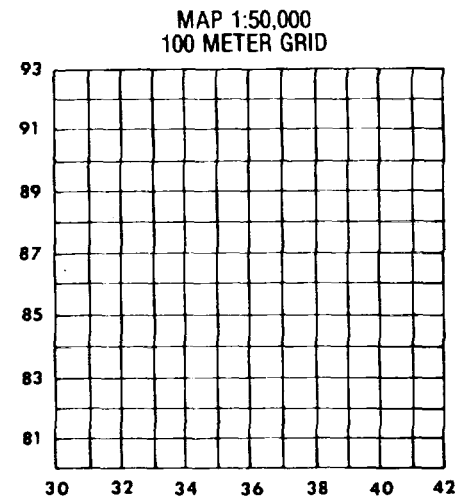
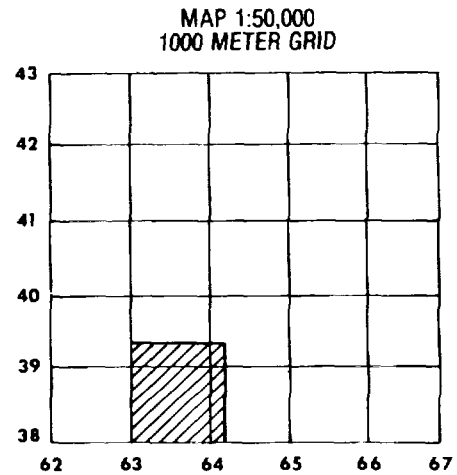

AR 902784

Figure 2-13. Labeling the special map

(4) When labeling the grid lines on the special map use the 100 meter value. For example, if you are preparing a map of the area which is located in the shaded square of a 1:50,000 map, you would label the grid lines of the special map as shown in figure 2-13, leaving off the 10,000 meter digit and adding the 100 meter digit.

b. Maps for a Temporary Range.

(1) Since a temporary range may be available to a unit for only one or two days, it is not practical to construct an elaborate range map. Therefore, the unit may begin the service practice by constructing an observed fire (OF) chart and then convert to a surveyed firing chart when survey is completed.

(2) The forward observer will be required to locate all targets using the shift from a known point method until survey has located his position and the OP is plotted on the firing chart. At that time, the forward observer can send polar coordinates in his call for fire.

(3) Survey should start at the earliest opportunity and, if possible, be completed prior to the start of the service practice, precluding the need for an OF chart. The survey party can provide the forward observer with a crude map by drawing 500-meter grid lines between the 1,000-meter lines on a 1:25,000 grid sheet. This creates a map of 1:50,000 scale. Each grid line is then labeled with its 100-meter (1,000 decimeters) designation. The grid sheet will then become a map with 1:5,000 scale (figure 2-14).

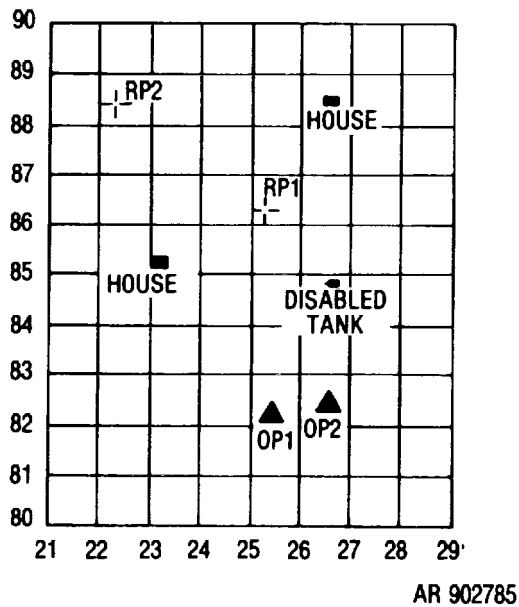

Figure 2-14. Special grid sheet map

(4) Critical points (buildings, road junctions, watertowers, targets, OPs, FPs, etc.) can be plotted on the grid sheet. These critical points should be located to the nearest 0.1 meter with an accuracy of 1 in 500. This information will be required to construct the special map.

c. Survey Requirements.

(1) A type of firing point marker which could be used on a permanent range is shown in figure 2-15. The marker is a metal rod with a flat piece of metal 12 inches by 6 inches welded to it. A 3-foot piece of pipe driven into the ground serves as a holder for the marker. Reference points in the impact area are used by the officer in charge to identify targets to the observer. For

example, FROM REFERENCE POINT THREE, GO RIGHT 35 MILS AND DOWN FROM THE SKYLINE ZERO MILS. THIS WILL PLACE YOU ON A SELF-PROPELLED GUN.

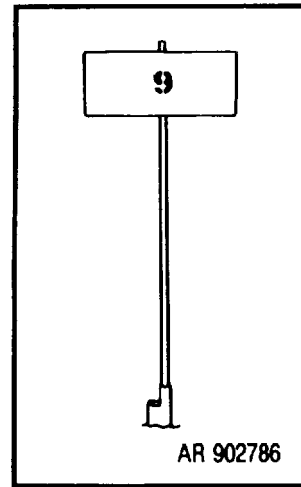

Figure 2-15. Firing point marker

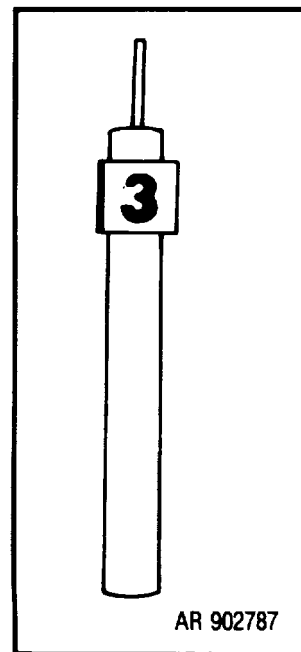

Figure 2-16. Permanent reference point

(2) The permanent reference point shown in figure 2-16 is a piece of telephone pole embedded in the ground. Numbers placed on all sides of the pole permit all-round identification. On temporary ranges, portable reference points can be positioned in the impact area. An example is the volleyball net pole shown in figure 2-17. Such a reference point need not be located by survey. The officer in charge of the OPs should determine the azimuth to the reference point prior to the conduct of the service practice. The battalion survey party should provide the battalion S3 with a list of targets, firing points and OPs, showing the coordinates and altitudes of each to the nearest 0.1 meter. The list should also reflect the target number and description for ease of identification.

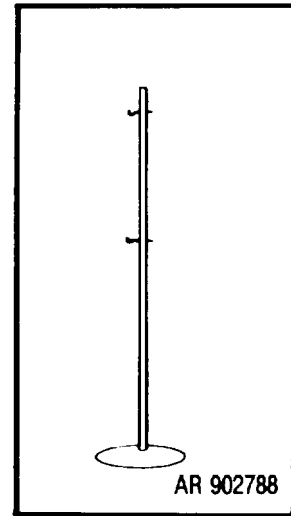

Figure 2-17. Temporary reference point

Here is a sample target list:

TGT	COORDINATES (M)	ALT (M)	DESCRIPTION
21	2168.1 3826.5 gun	391	Self-propelled
22	2207.4 3794.6 container	389	Red 8-inch propellant
23	2294.5 3788.2 auto tire	392	Half buried white

Section II. SERVICE UPON RECIEPT OF EQUIPMENT

2-4. General. When a new or reconditioned trainer is first received, it is the responsibility of the officer-in-charge to determine whether the trainer has been properly prepared for service by the supplying organization and whether it is in condition to perform its mission.

2-5. Inspecting and Servicing the Equipment.

a. Inspect and service the trainer as follows:

- (1) Remove trainer from shipping and storage chest.
- (2) Remove volatile corrosion inhibitor.
- (3) Remove corrosion-preventive compound.

(4) Inspect all assemblies for excessive wear, damage, missing parts or corrosion, proper assembly, and correct adjustment. Inspect the safety and all levers and locks for proper functioning.

(5) Check to see that trainer is complete with all tools and equipment.

(6) Clean and lubricate (Par. 3-4).

2-6. Setting-up Instructions for the M31 Trainer.

a. Assembly. The 14.5-mm trainer has four major assemblies which are assembled in the following sequence when emplacing the 14.5-mm trainer on the tripod. The four sections are packed in the shipping[storage chest along with maintenance tools and equipment. To set up the trainer follow steps 1 through 9.

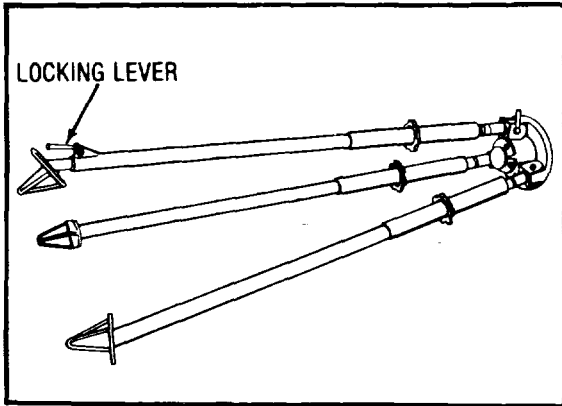

Step 1: Remove the tripod assembly from the storage chest. (Note that the rear leg has the locking lever near the bottom).

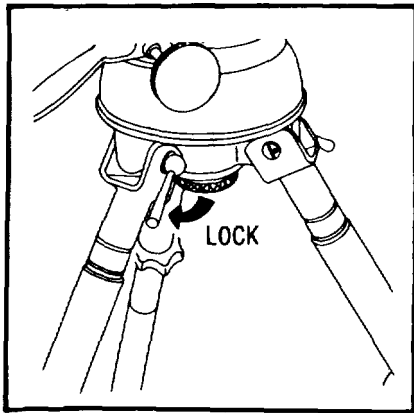

Step 2: With the rear leg pointing opposite to the direction of fire, spread the two front legs about 4-1/2 feet apart and lock them in place by turning the leg locking levers to the outward position.

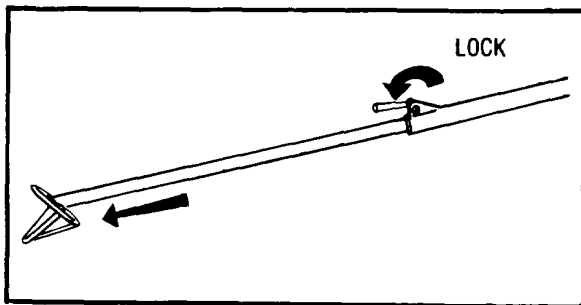

Step 3: Unlock the locking lever at the bottom of the rear leg and extend the leg about 15 inches. Lock it in the extended position by tightening the lower locking lever. Then place the rear leg in the ground so the top of the tripod assembly is approximately level.

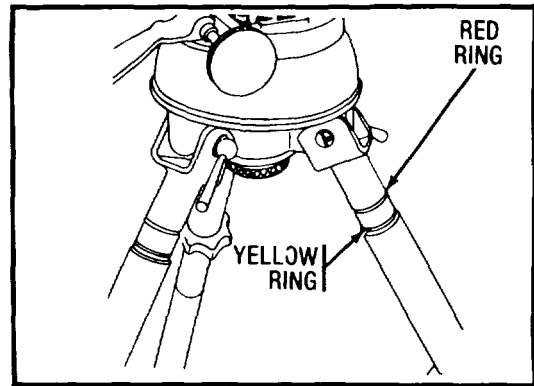

Step 4: Extend each leg until the yellow ring can be seen. The yellow ring indicates the center of the threads. There are two red rings on each leg which indicates that the rotating collar has reached the end of the threads. Do not turn the rotating collar beyond the red rings.

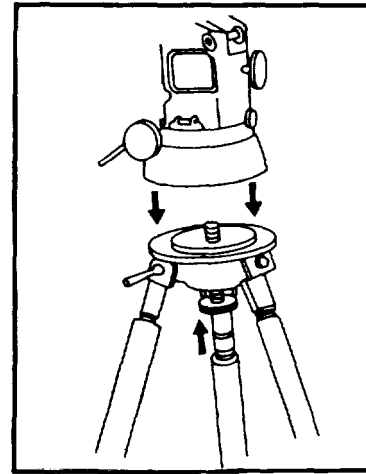

Step 5: remove the mount assembly from the storage chest and place it on top of the tripod assembly. Align key on tripod base with keyway in bottom of mount. Then tighten the mount locking screw into the mount assembly.

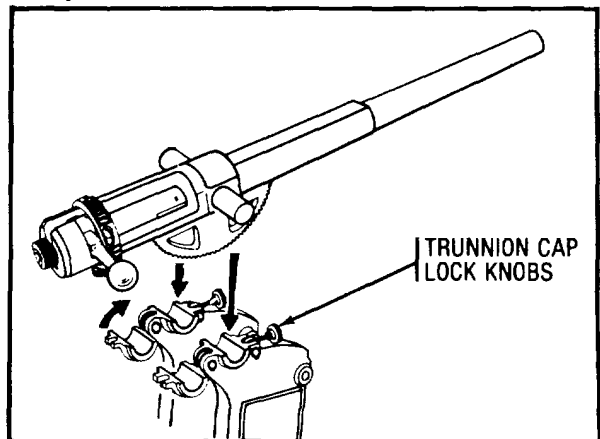

Step 6: Open the trunnion caps. Remove the barrel from the chest and attach it to the mount assembly by placing the trunnions in the recesses. Lock the trunnion caps.

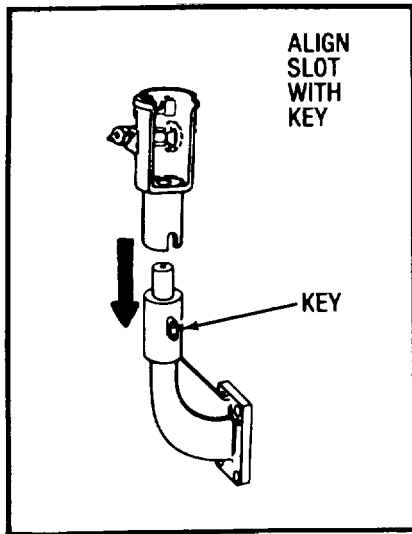

Step 7: Attach the telescope socket, holder, or support assembly to the mount assembly.

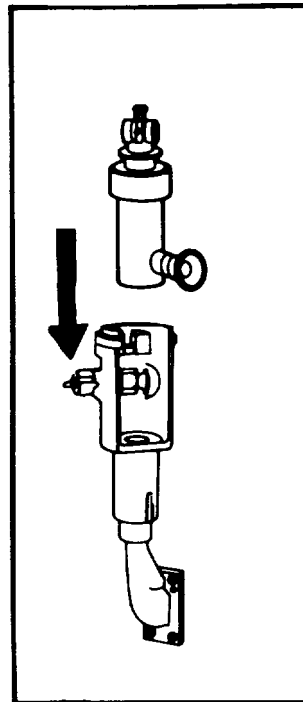

Step 9: Place the panoramic telescope into the telescope socket, holder, or support assembly.

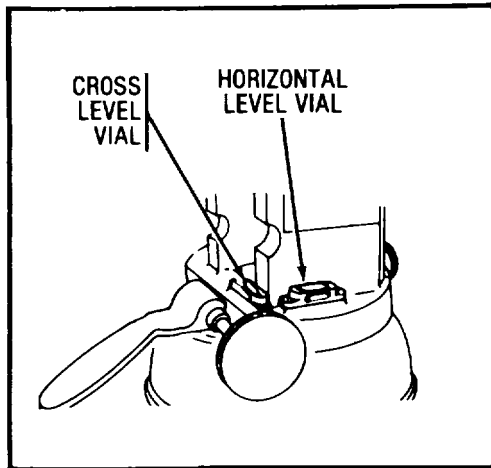

Step 8: Level the mount. There are two level vials on the mount. With the tube pointed in the approximate direction of fire, turn the traversing handwheel until one of the level vials is directly over the rear leg. This vial will be known as the "cross level vial". In this position the other level vial will be near the right front leg and will be known as the "horizontal level vial". The horizontal level vial bubble is centered by turning the rotating collar of the rear leg. The cross level vial bubble is centered by simultaneously turning the rotating collar of the two front legs either toward each other or away from each other.

b. Boresighting. The distant aiming point method of boresighting is used when the 14.5-mm trainer is mounted on the tripod. To boresight the trainer follow steps 1 through 5.

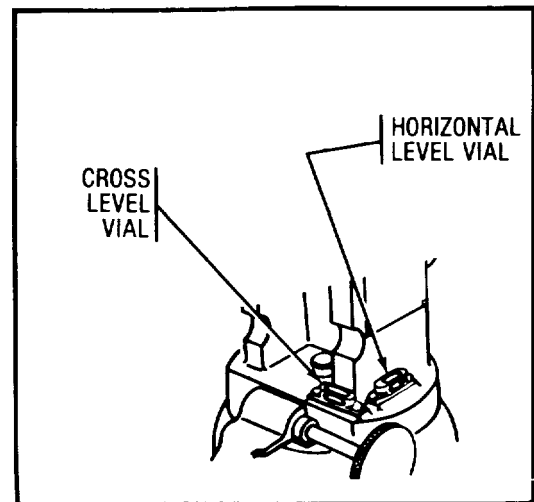

Step 1: Center both the horizontal and the cross level vial bubbles.

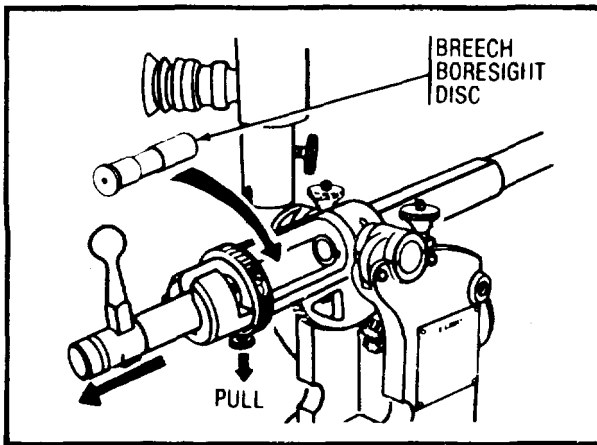

Step 2: Remove the bolt. Install breech boresight disc. (The breech boresight disc is a fired cartridge case that has a 1/16-inch hole drilled in the center of the cartridge base.

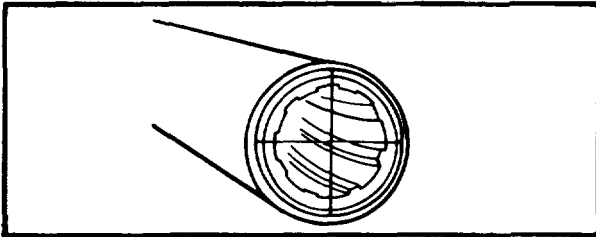

Step 3: Attach cross thread to the muzzle.

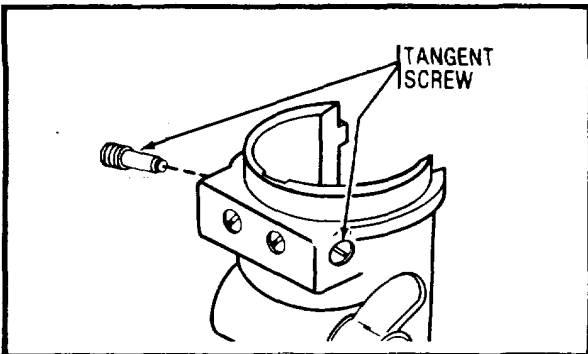

Step 4: Sight the tube onto a distant aiming point (1, 500 meters). Aline panoramic telescope sight on the same distant aiming point using the tangent screws on the telescope mount or the telescope boresight adjusting screw

NOTE

When the M115/M117 panoramic telescope is mounted in the support it is 1600 mils out of boresight. Since it is impractical to turn the azimuth scale 1600 mils using the boresight adjusting screw, the telescope head will be turned to the distant aiming point, and then the reset counter will be set to 3200. Use only the lower scale for laying and referring.

c. *End-for-end test.* To perform the end-for-end test of the gunner's quadrant, refer to TM 9-1290-200-15 and the operator's manual for the major caliber weapon.

2-7. Installation Instructions for the M1091 M109A1/M115/M110 Howitzers and M107 Guns. The 14.5-mm gun barrel is mounted in the breech of the M109/M109A1 155-mm howitzers, the M107 175-mm gun and the M110 8-inch howitzer as a subcaliber device. To mount the gun barrel and boresight the piece follow steps 1 through 13.

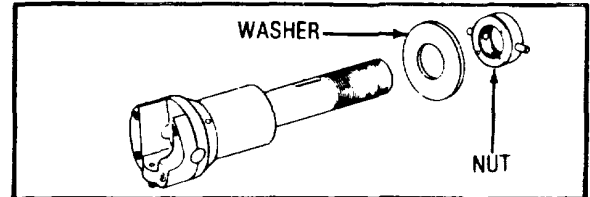

Step 1: Remove the obturator group, obturator spring, and firing mechanism housing assembly (refer to the operator's manual for the major caliber weapon).

Step 2: Remove adapter nut and washer.

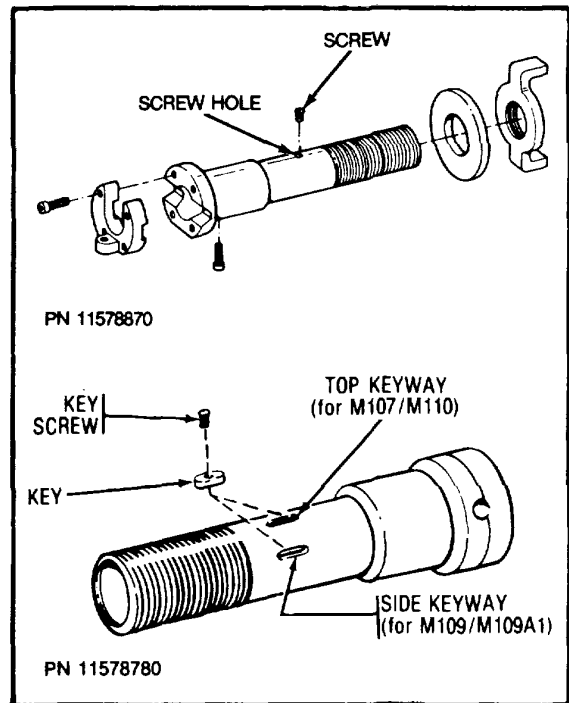

Step 3: Install the key in the appropriate keyway and secure with a screw: The top keyway is for the M107/M110 weapons, the side keyway is for the M109 and M109A1 155-mm howitzers. Adapter PN 11578870 has no keyway. Install screw in appropriate screw hole.

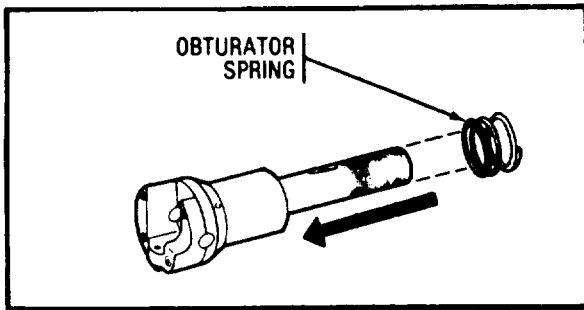

Step 4: Place the obturator spring over the adapter.

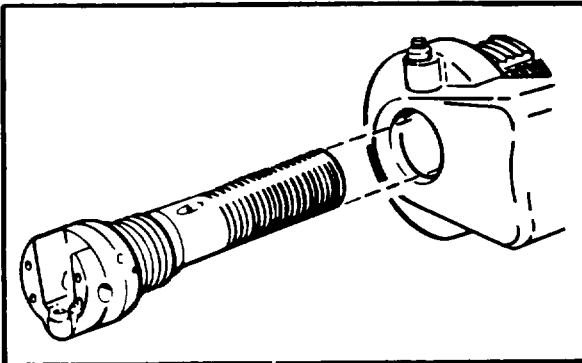

Step 5: Insert the adapter (top up) in the breech-block.

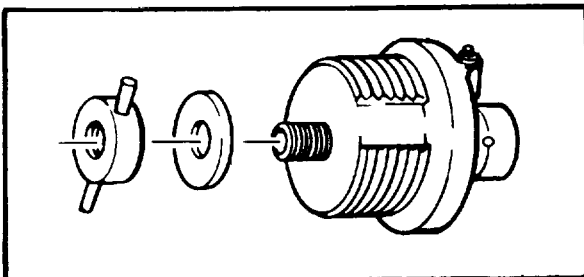

Step 6: Place the washer on the adapter. Tighten the nut all the way down, then loosen it one turn. The loosening of the nut allows the breech to be closed fully.

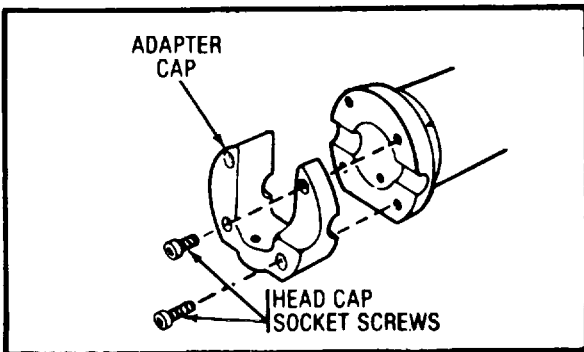

Step 7: Remove the four head cap socket screws and the adapter cap.

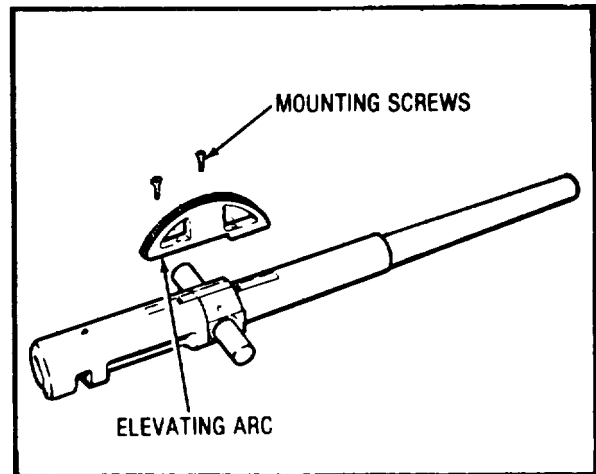

Step 8: Remove the elevating arc from the gun barrel by removing the two mounting screw.

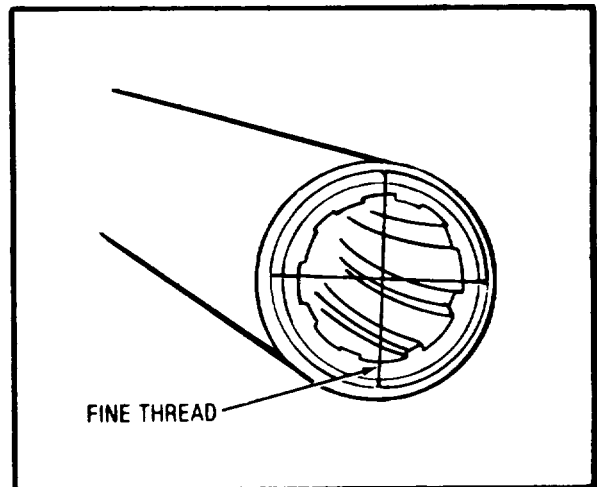

Step 9: Attach fine thread across the four witness marks on the end of the tube by using a rubber band. Also place boresight strings on the muzzle of the howitzer.

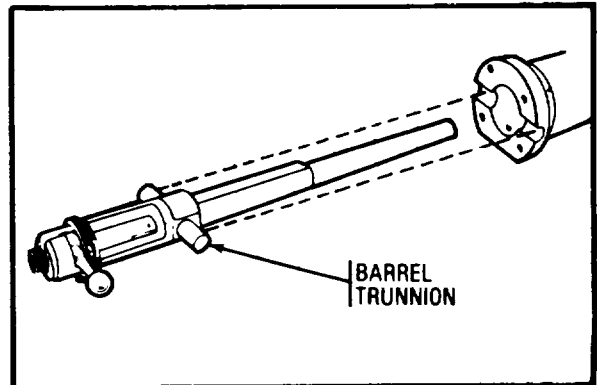

Step 10: Place the gun barrel in the adapter and engage the barrel trunnions with the adapter slots.

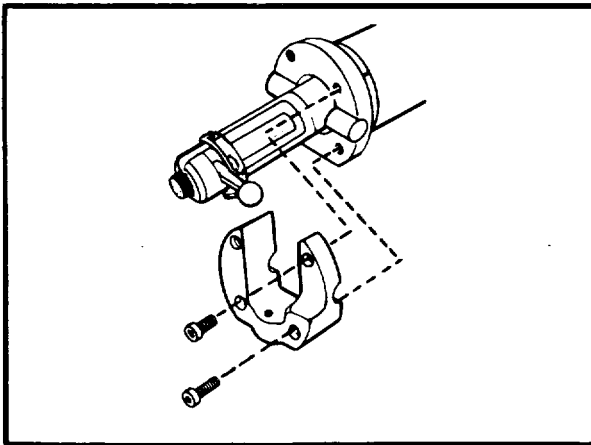

Step 11. Lock the barrel into position by securing the adapter cap to the body (short screw in upper right hole). Do not tighten the four screws yet.

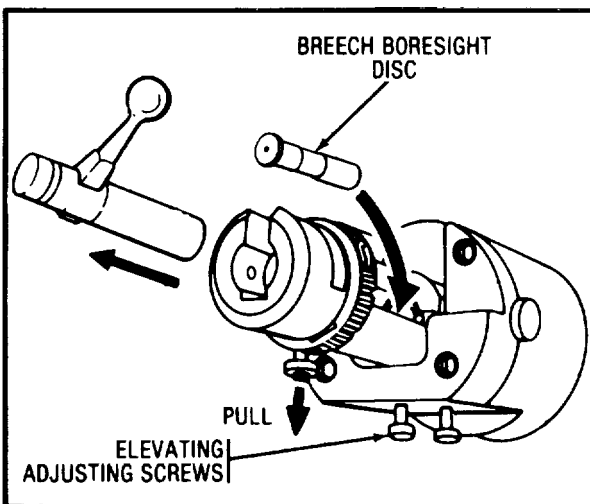

Step 12: Close the breech, remove the bolt by pulling down on the locking cap and pulling bolt to the rear. To boresight the 14.5 mm device:

1. Tighten both elevating adjusting screws against the barrel.
2. Place the breech boresight disc in the cartridge chamber.
3. Sighting through the breech boresight disc, align the horizontal boresight string of the 14.5 mm barrel with the horizontal boresight string of the primary weapon by adjusting elevating adjusting screws (the rear screw lowers the barrel, the front screw raises the barrel).
4. Tighten the four adapter cap screws.
5. Verify the alinement of the muzzle horizontal boresight strings. Remove the muzzle boresight strings from the primary weapon.
6. Select a distant aiming point (DAP) at least 1,500 meters from the weapon.

7. Sighting through the breech boresight disc align the 14.5mm barrel on the DAP.

8. Refer the panoramic sight to the DAP. The reading should be 3200 mils. If the reading is not 3200 adjust to 3200 mils.

9. Remove boresight disc and install bolt.

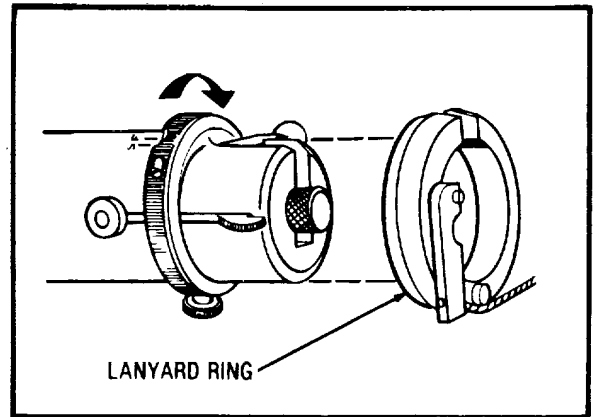

Step 13: Turn the safety ring to the "fire" position. Place the lanyard ring over the rear of the breech, matching the openings of breech and the lanyard ring.

2-8. Installation Instructions for the M101A1 Howitzer. The 14.5-mm gun barrel is mounted in the breech of the M101A1 howitzer as a subcaliber device. To mount the gun barrel, follow steps 1 through 8.

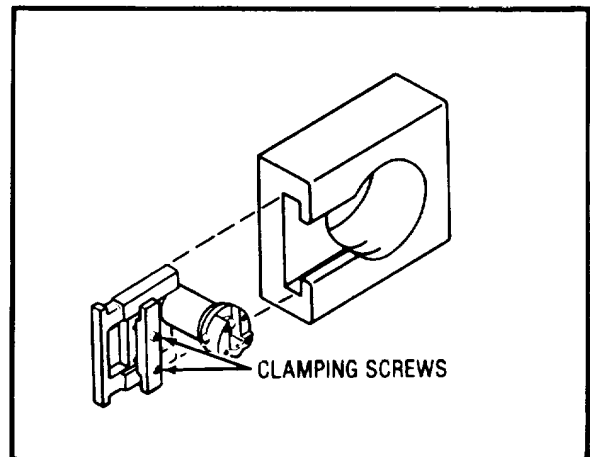

Step 1: Open the breech and place the adapter in the breech recess. (If the weapon is going to be moved, remove the breech block). Make sure the two clamping screws are in an unscrewed position. Tighten the two clamping screws.

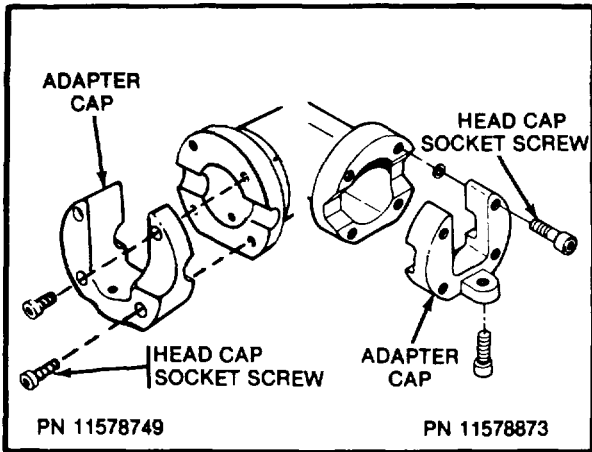

Step 2: Remove the four head cap socket screws and the adapter cap.

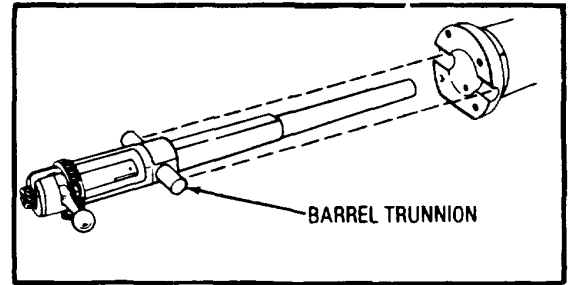

Step 5: Place the gun barrel in the adapter and engage the barrel trunnions with the adapter slots.

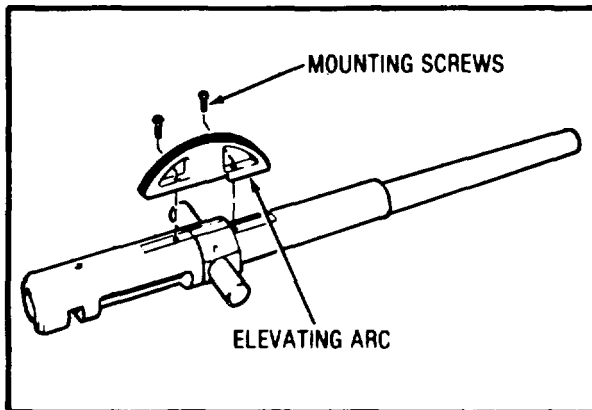

Step 3: Remove the elevating arc from the gun barrel by removing the two mounting screws.

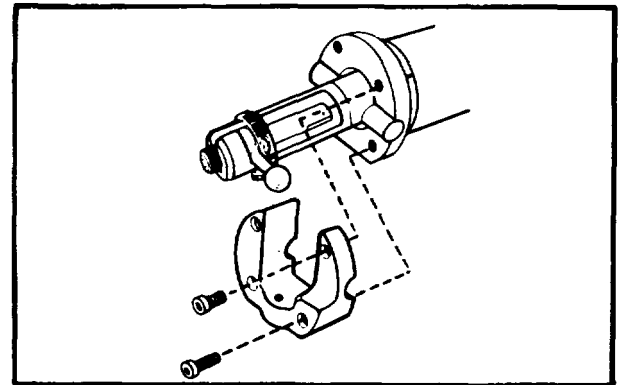

NOTE

Adapter PN 11578873 does not have short screws.

Step 6: Lock the barrel into position by securing the adapter cap to the body (short screw must be in upper right hole). Do not tighten the four screws yet.

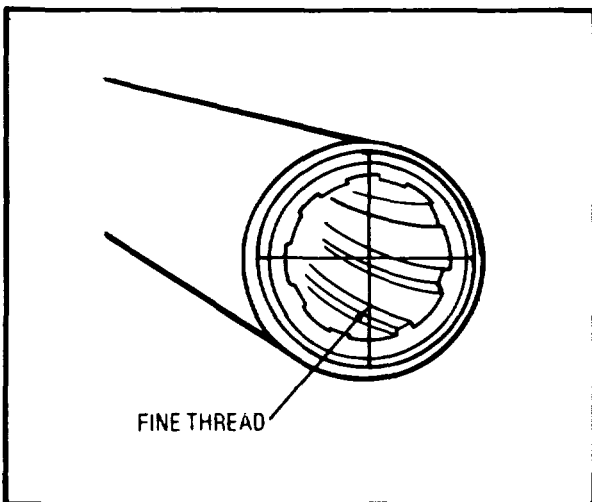

Step 4: Attach fine thread across the four witness marks on the end of the tube by using a rubber band. Also place boresight strings on the muzzle of the bowitzer.

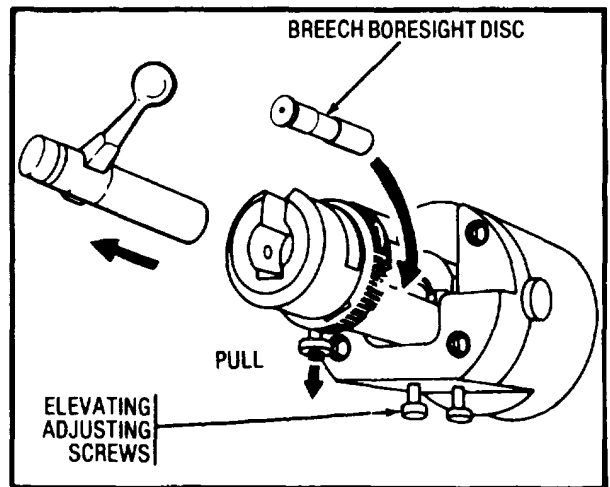

Step 7: Boresight the 14.5mm gun in the following sequence:

1. Remove the bolt and install the breech boresight disc.

2. Sight through the breech boresight disc and align the horizontal boresight string of the gun with the horizontal cross-hair string on the howitzer. To raise the barrel, tighten the front elevating adjusting screw and loosen the rear elevating adjusting screw. To lower the barrel, loosen the front screw and tighten the rear screws.

3. When the horizontal crosshairs are in alignment and the two elevating adjusting screws are tight, tighten the four head cap socket screws.

4. Remove the howitzer boresight strings.

5. Select a distant aiming point (DAP) at least 1,500 meters from the weapon. Sighting thru the breech boresight disc align the 14.5-mm barrel on the DAP.

6. Refer the panoramic sight to the distant aiming point. The reading should be zero. If it is not set to zero, turn azimuth knob until azimuth scale reads zero, then adjust the sight onto the distant aiming point using the tangent adjusting screw.

7. Remove boresight disc and install bolt.

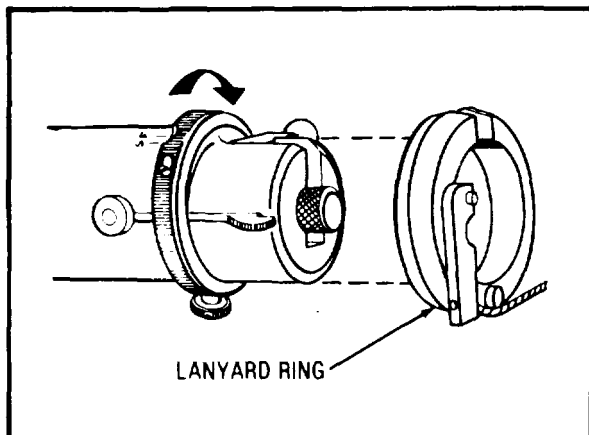

Step 8: Turn the safety ring to the "tire" position. Place the lanyard ring over the rear of the breech, matching the openings of breech and the lanyard ring.

2-9. Installation Instructions for the M102 Howitzer. The 14.5-mm gun barrel is mounted in the breech of the M102 howitzer as a subcaliber device. To mount the gun barrel, follow steps 1 through 8.

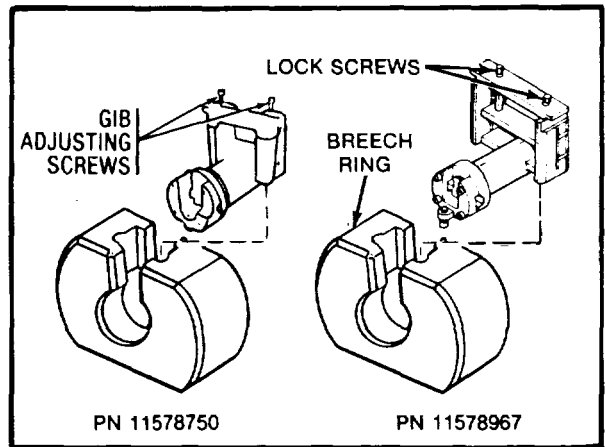

Step 1: Open the breech and place the adapter in the breech recess. The gib adjusting screws should be in the unscrewed position. Make sure the adapter rests against the breech ring then turn the gib screws finger tight. Tighten the screws an additional 1/2 turn. Loosen lock screws before positioning adapter PN 11578967 in breech recess. Tighten the screws to lock adapter in breech ring.

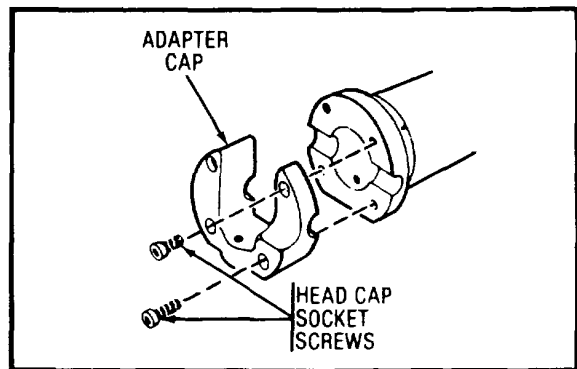

Step 2: Remove the four head cap socket screws and the adapter cap.

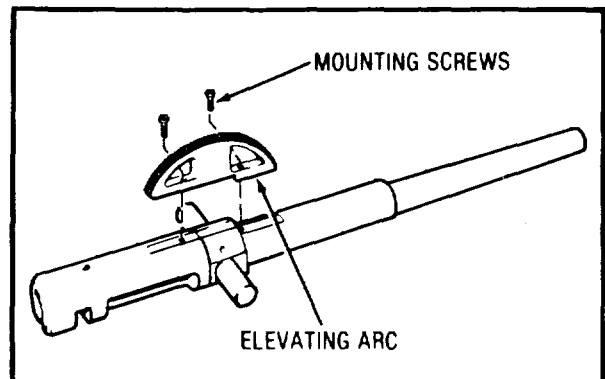

Step 3: Remove the elevating arc from the barrel by removing the two mounting screws

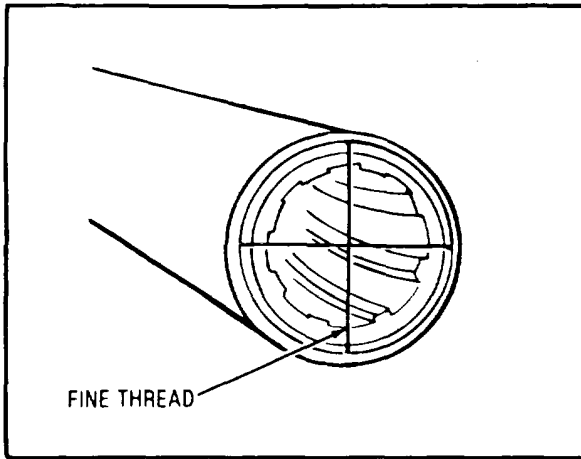

Step 4: Attach fine thread across the four witness marks on the end of the tube by using a rubber band. Also place boresight strings on the muzzle of the howitzer

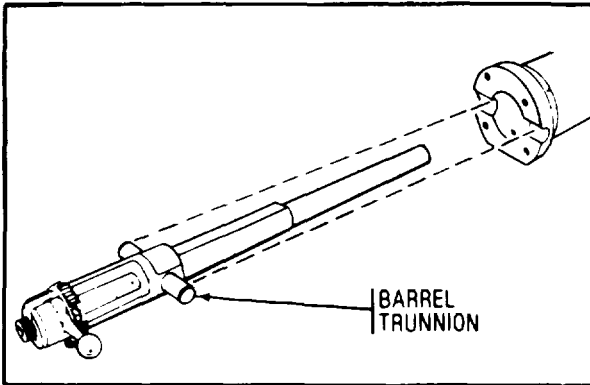

Step 5: Place the gun barrel in the adapter and engage the barrel trunnions with the adapter slots.

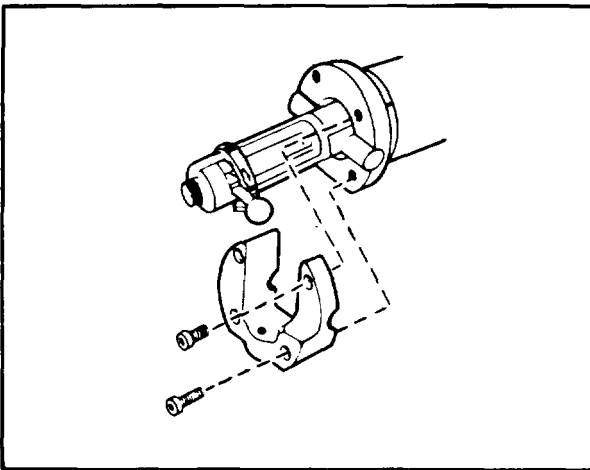

Step 6: Lock the barrel into position by securing the adapter cap to the body. Do not tighten the four screws yet.

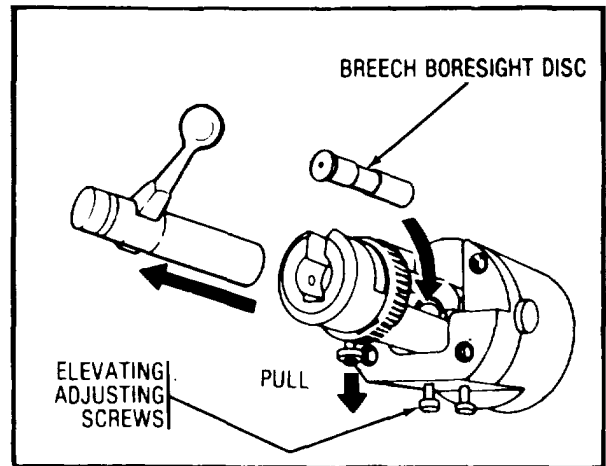

Step 7: Boresight the 14.5-mm gun in the following sequence:

1. Remove the bolt and install the breech boresight disc
2. Sight through the breech boresight disc and align the horizontal boresight string of the gun with the horizontal cross-hair string on the howitzer. To raise the barrel, tighten the front elevating adjusting screw. To lower the barrel, loosen the front screw and tighten the rear screws.
3. When the horizontal crosshairs are in alignment and the two elevating screws are tight, tighten the four head cap socket screws.
4. Remove the howitzer boresight strings.
5. Select a distant aiming point (DAP) at least 1,500 meters from the weapon. Sighting through the breech boresight disc align the 14.5-mm barrel on the DAP.
6. Refer the panoramic sight to the distant aiming point. The reading should be 3200 mils. If the reading is not 3200, adjust it to 3200 mils.
7. Remove breech boresight disc and install breech-bolt.

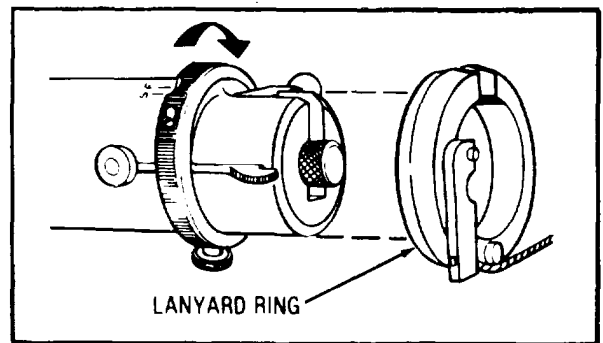

Step 8: Turn the safety ring to the "tire" position. Place the lanyard ring over the rear of the breech, matching the openings of breech and the lanyard ring.

2-10. Installation Instructions for the M114A1 Howitzer. To mount the barrel in the M114A1 howitzer and boresight the device, follow steps 1 through 13.

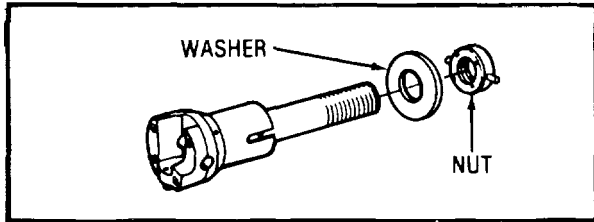

Step 1: To remove the obturator group, obturator spring, and firing mechanism housing assembly, refer to the operator's manual for the major caliber weapon.

Step 2: Remove adapter nut and washer.

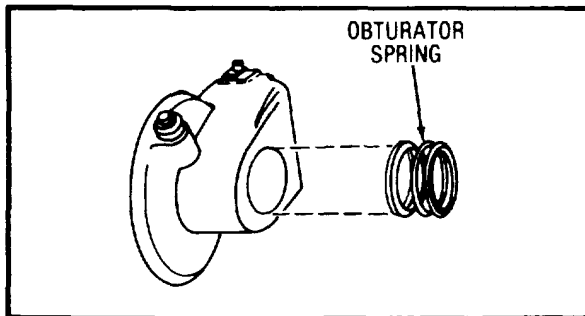

Step 3: Place the obturator spring in the firing mechanism housing recess.

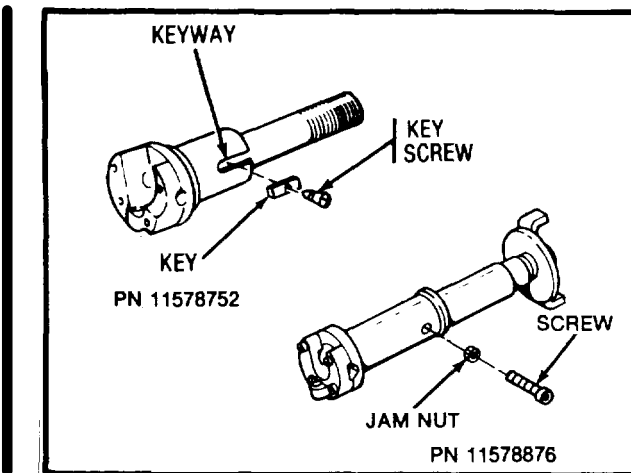

Step 4: Install the key in the keyway and secure with a screw.

NOTE

Adapter PN 11578876 does not have keyway. Use as issued with screw and jam nut.

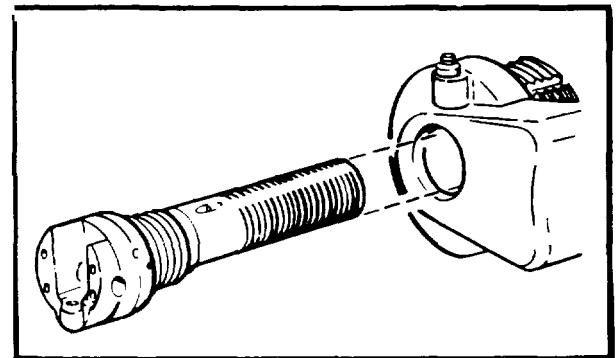

Step 5: Insert the adapter (top up) in the breech-block.

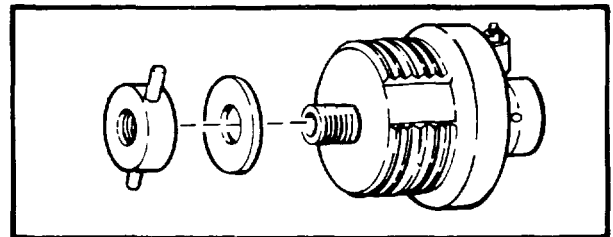

Step 6: Place the washer on the adapter. Tighten the nut all the way down, then loosen it two turns. The loosening of the nut allows the breech to be closed fully.

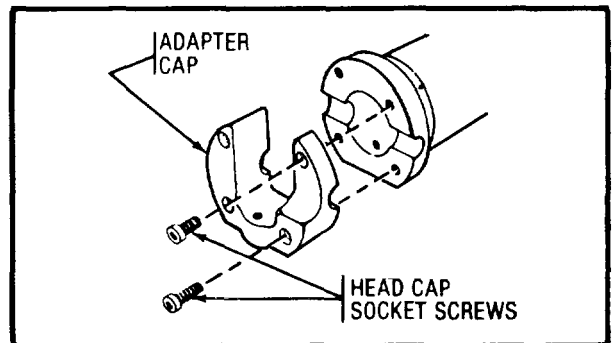

Step 7: Remove the four head cap socket screws and the adapter cap.

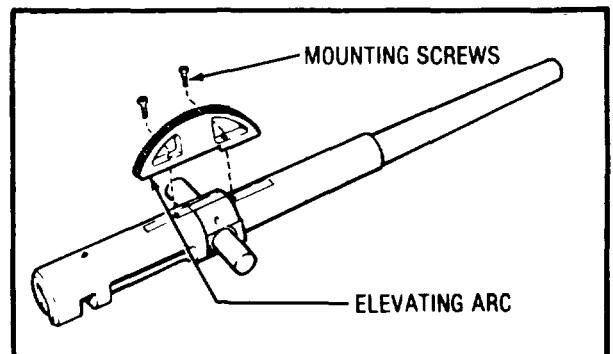

Step 8: Remove the elevating arc from the gun barrel by removing the two mounting screw.

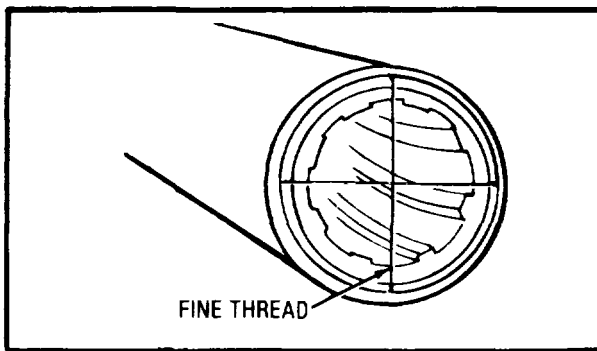

Step 9: Attach fine thread across the four witness marks on the end of the tube by using a rubber band. Also place boresight strings on the muzzle of the howitzer.

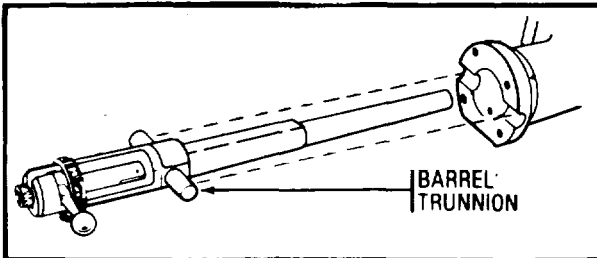

Step 10: Place the gun barrel in the adapter and engage the barrel trunnions with the adapter slots.

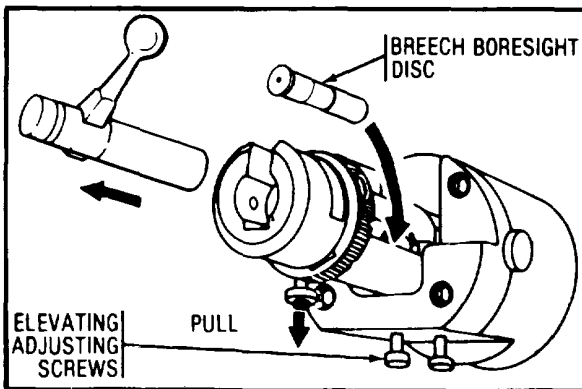

Step 11: Lock the barrel into position by securing the adapter cap to the body. Small bolt goes in upper right hole. Do not tighten the four screws yet.

Step 12: Close the breech, remove the bolt by pulling down on the locking cap and pulling bolt to the rear. To boresight the 14.5-mm device:

1. Tighten both elevating adjusting screws against the barrel.
2. Place the breech boresight disc in the cartridge chamber.
3. Sighting through the breech boresight disc, align the horizontal boresight string of the 14.5-mm barrel with the horizontal boresight string of the primary weapon by adjusting the elevating adjusting screws (the rear screw lowers the barrel, the front screw raises the barrel).
4. Tighten the four adapter cap screws.
5. Verify the alignment of the muzzle horizontal boresight strings. Remove the muzzle boresight strings from the primary weapon.
6. Select a distant aiming point (DAP) at least 1,500 meters from the weapon.
7. Sighting through the breech boresight disc align the 14.5-mm barrel on the DAP.
8. Refer the panoramic sight on the DAP. The reading should be zero. If it does not read zero, set to zero. Then adjust the sight on the distant aiming point using the target adjusting screws.
9. Open breech and remove boresight strings from muzzle of subcaliber device.
10. Close breech. Remove boresight disc and install bolt.

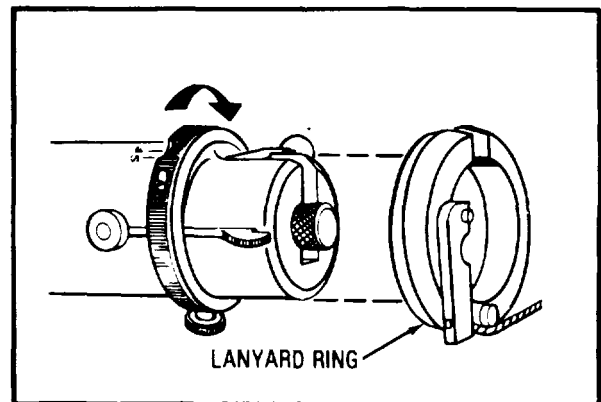

Step 13: Turn the safety ring to the "fire" position. Place the lanyard ring over the rear of the breech, matching the openings of breech and the lanyard ring.

2-10.1. Installation Instructions for the M198 Howitzer. To mount the barrel in the M198 howitzer and boresight the device, follow steps 1 through 11.

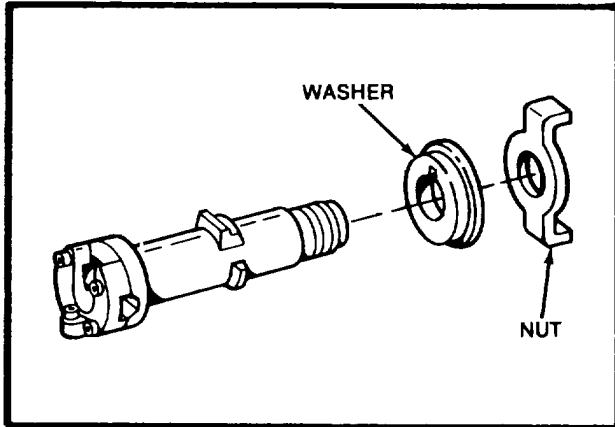

Step 1: To remove the firing mechanism, firing mechanism block, and obturator spindle assembly, refer to the operator's manual for the major caliber weapon.

Step 2: Remove adapter nut and washer.

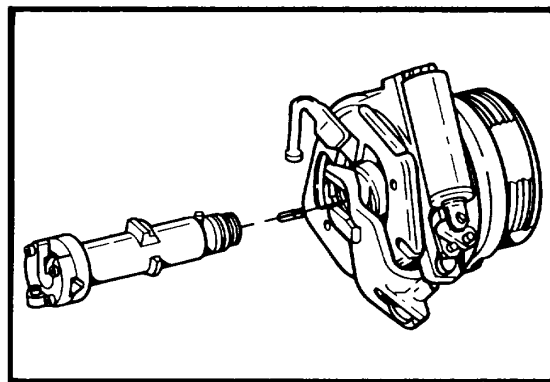

Step 3: Insert the adapter (top up) in the breechblock.

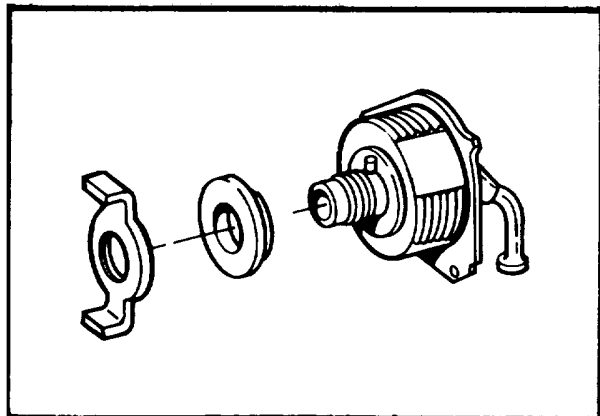

Step 4: Align pin on adapter with slot in washer and install washer. Install nut and tighten completely.

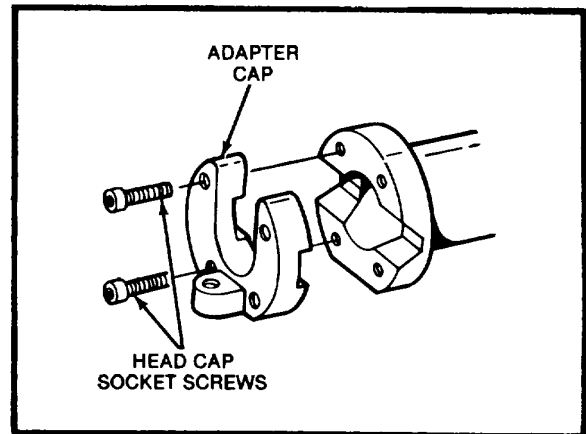

Step 5: Remove the four head cap socket screws and the adapter cap.

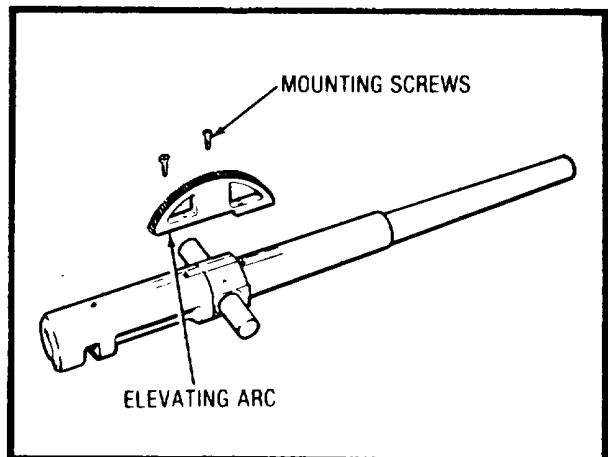

Step 6: Remove the elevating arc from the gun barrel by removing the two mounting screws.

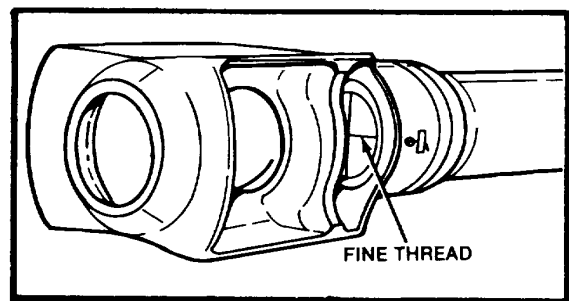

Step 7: Attach fine thread across the four witness marks on the end of the tube by using a rubber band. Also place boresight strings on the muzzle of the howitzer.

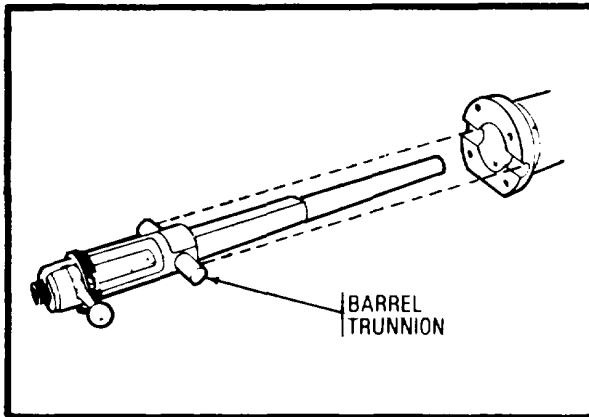

Step 8: Place the gun barrel in the adapter and engage the barrel trunnions with the adapter slots.

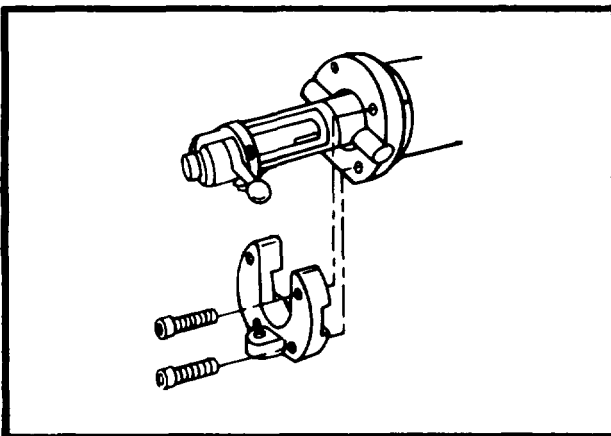

Step 9: Lock the barrel into position by securing adapter cap to the body. Do not tighten the four screws yet.

CAUTION

Use caution if opening breech with barrel assembly installed to prevent barrel assembly from striking top carriage.

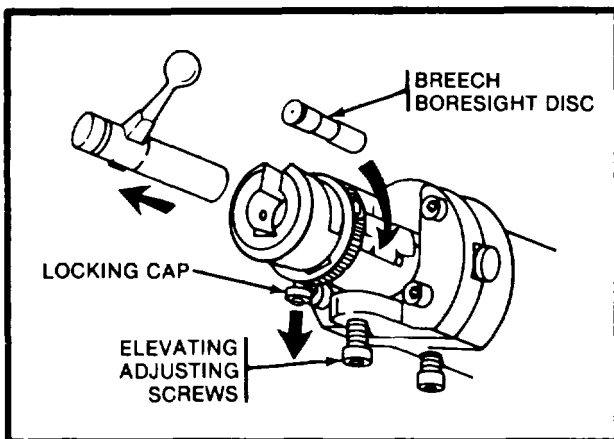

Step 10: Close the breech, remove the bolt by pulling down on the locking cap and pulling bolt to the rear. To boresight the 14.5-mm device:

1. Tighten both elevating adjusting screws against the barrel.
2. Place the breech boresight disc in the cartridge chamber.
3. Sighting through the breech boresight disc, align the horizontal boresight string of the 14.5-mm barrel with the horizontal boresight string of the primary weapon by adjusting the elevating adjusting screws (the rear screw lowers the barrel, the front screw raises the barrel).
4. Tighten the four adapter cap screws.
5. Verify the alignment of the muzzle horizontal boresight strings. Remove the muzzle boresight strings from the primary weapon.
6. Select a distant aiming point (DAP) at least 1,500 meters from the weapon.
7. Sighting through the breech boresight disc, align the 14.5-mm barrel on the DAP.
8. Refer the panoramic sight on the DAP. The reading should be zero. If it does not read zero, set to zero. Then adjust the sight on the DAP using the target adjusting screws.
9. Open breech and remove boresight strings from muzzle of subcaliber device.
10. Close breech, remove boresight disc and install bolt.

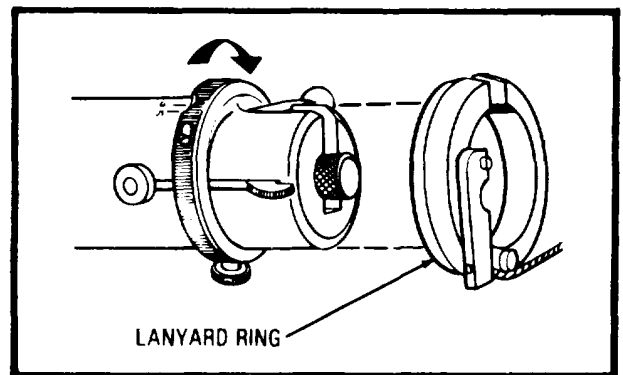

Step 11: Turn the safety ring to the :fire: position. Place the lanyard ring over the rear of the breech, matching the openings of breech and the lanyard ring.

Section III. OPERATION UNDER USUAL CONDITIONS

2-11. General. This section contains training procedures, and instructions for operation of the trainer M31 and the associated inbore subcaliber devices under conditions of moderate temperature and humidity. For operation under unusual conditions see Section IV

any other easy, logical method can be used. Additionally, problems may be encountered when traversing self-propelled weapons. During large deflection changes, the weapons should be traversed in unison to avoid the possibility of hitting adjacent weapons with gun tubes.

2-12. Training Procedures.**WARNING**

During firing mission, personnel should wear safety glasses, suitable ear protection devices, and stand to the rear of the weapon barrel.

CAUTION

During firing, the bore should be cleaned with the bronze bore brush after every 10 to 15 rounds to reduce the possibility of a muzzle burst.

a. Firing Battery Procedures.

(1) When the 14.5-mm trainer is mounted in the primary weapon as a subcaliber device, the on-carriage fire control equipment and traversing and elevating mechanism will be used to lay the weapon for direction and elevation.

(2) During firing, the weapon can be serviced by a four-man crew-chief of section, gunner, assistant gunner, and number 1 cannoneer. The chief of section, gunner, and assistant gunner will perform their duties as though the primary weapon is being fired, except the breech is not opened and closed. Cannoneer number 1 will load the piece.

(3) During the conduct of the fire mission, realistic commands are announced to the section; e.g., FIRE MISSION, BATTERY ADJUST AT MY COMMAND, CHARGE 1, DEFLECTION 3270, QUADRANT 365, BATTERY 2 ROUNDS IN EFFECT (NUMBER 3 ONE ROUND SHELL HE, LOT X, FUZE Q HAVE BEEN DESIGNATED AS STANDARD). Each command will require the section to respond in much the same manner as though the primary weapon were being fired.

(4) When the 14.5-mm bursts are more than five meters apart, the observer will have difficulty in spotting the center of the two bursts for range. Therefore, when positioning the weapons, the lateral distance between tubes should be about one-tenth the normal emplacement lateral distance. Special corrections can be applied to fire for effect data if the weapons are more than the normal distance apart, but it is unrealistic to habitually apply special corrections during fire for effect. Minimum quadrant elevation should be computed and reported as normal operations. Crest clearance for the 14.5-mm trainer is five decimeters. Either the tabular or graphical solution is acceptable.

(5) When using the inbore version in a six-gun battery mode with all of the weapons separated by five meters or less, some special techniques must be used. Aiming posts and/or collimators should be identified by section to preclude a mixup of aiming points between sections. Numbers, section colors, lights, or

(6) There is considerable buildup of cosmoline in the tube during firing, and if it is not removed, there is a loss in range. Eventually the cosmoline buildup will cause a muzzle burst.

(7) It is not necessary to remove the 14.5-mm tube from the adapter for cleaning. Remove the bolt and swab the bore from the breech end of the tube. After firing has been completed and the adapter is removed, both the howitzer's primary tube and the 14.5-mm tube must be cleaned as though both tubes were fired. The adapter bore is cleaned using the same cleaning material as used for the 14.5-mm device.

(8) A muzzle burst is currently considered a malfunction. In the event of a muzzle burst, the officer in charge of firing should report the malfunction to local ammunition authorities. Normally the ammunition lot will not be suspended, however, the details of the malfunction should be reported through proper channels.

b. Observer Procedures.

(1) When the observer is provided a special map as previously discussed, normal observer procedures (including the use of an OF fan) are used to determine target locations. The OT factor determined by the observer is based upon thousands of decimeters rather than thousands of meters. For example, an observer-target distance of 2,800 decimeters (280 meters) would result in an OT factor of 3. The observer corrects for deviation by multiplying the measured deviation by the OT factor and announcing his corrections to the nearest ten decimeters; i.e., RIGHT 60.

(2) The observer uses the bracketing method of range adjustment. Caution should be exercised in establishing the range bracket because the observer in many cases will think his rounds are much closer to the target than they actually are. As an example, if the rounds are 30 meters (300 decimeters) short of the target, the observer should announce ADD 400 in order to obtain a range bracket.

(3) Air observer (AO) training can be conducted using a helicopter. The aircraft should fly at an altitude of about 200 feet to the rear of the firing position. The AO should be given *shot* ten seconds before the weapons fire, in order to properly position the aircraft for observation.

c. *Fire Direction Center Procedures.*

(1) *Manual solution.*

(a) The 1:25, 000 scale grid sheet is set up in the same manner as for firing the main tube except that the space between grid lines is 1, 000 decimeters.

(b) The target grid is oriented in the same manner as with other field artillery weapons. The horizontal control operator (HCO) plots the target using the 1:25, 000 coordinate scale and determines chart data (range and deflection) using the 1:25, 000 scale range-deflection protractor or using the graphical firing table (GFT) fan determine deflection and elevation. The vertical control operator (VCO) determines site using the special map and the 14.5-mm graphical site table (GST).

(c) When the difference in altitude is determined in feet or meters, it must be converted to decimeters. For example, if the difference in altitude is 31.2 meters, the VCO would use 312 decimeters as the vertical interval (VI) and the range announced by the HCO to determine site. Instructions and examples on GST usage are printed on the back of the GST. The computer, using the 14.5-mm graphical firing table (GFT), computes the gun data and announces the fire commands to the guns.

(d) Because of short range of the 14.5-mm trainer, small vertical differences, such as one or two meters, equate to several meters in range. Therefore, in order to obtain valid corrections when conducting a registration, the height of the barrel above the surveyed battery center should be considered. When constructing a firing chart the surveyed altitude of the battery should be increased the following amount.

Model	Howitzer	Decimeters
M101A1	105-mm	+10
M102	105-mm	+10
M114A1	155-mm	+15
M109/M109A1	155-mm	+20
M110	8-inch	+20
M107	175-mm (Gun)	+20
M198	155-mm	+20

(2) *FADAC Solution.* The M18 FADAC tape (revision 5) will be utilized for the FADAC solution.

d. *Mission Procedures.*

(1) During practice for unit ATT/ORTT, the following missions may be conducted using the M31:

- (a) Battery emergency mission
- (b) High burst registration
- (c) Mean-point-of-impact registration
- (d) Precision impact registration
- (e) Destruction mission
- (f) MET plus VE fire for effect
- (g) High-angle battalion mass mission
- (h) Battalion TOT
- (i) Coordinated illumination mission

Those missions that cannot be conducted are time transfers and area time adjustments.

(2) During the march from the rendezvous area to a firing position (or from one firing position to another), an emergency mission may be conducted if the 14.5-mm barrel has been previously installed and boresighted (para. 2-7 through 2-10.1). The emergency mission position may become a primary position requiring survey, communication, and other improvements.

(3) During a battalion exercise the survey party may establish an 01-02 base. If the point selected for the MPI or HB is about 300 meters down range, then the length of the base should be 60 to 100 meters. A good rule to follow is that the length of the base should be no less than 1/5 the observing range. Care should be exercised when selecting the 01-02 base; make sure that the guns do not fire over the personnel occupying the 01-02 base.

NOTE

Do not apply registration corrections obtained from a HB registration to subsequent firing data. Do not attempt to transfer fire using the 3-or 6-second delay round.

(4) When conducting a high burst registration, you can use either the 3-second or 6-second delay round. The chart location of the high burst will be at the appropriate deflection and at a GT range corresponding to 3or 6seconds. This plot will provide orienting data for 01 and 02. The quadrant elevation fired should correspond to a time of flight 0.6 seconds greater than the present time (3 or 6 seconds) of the round. Eight rounds will normally provide sufficient data to obtain corrections.

(5) The same 01-02 base can be used to conduct an MPI registration provided the chart location of the MPI is about the same as the chart location of HB. Registration corrections obtained from an MPI registration can be applied to all subsequent fire using the PD fuze.

(6) Precision fire is conducted with one gun on a point target to obtain registration corrections or to destroy a target. Since there is no fragmentation of the projectile, most targets should be considered destroyed after one or two target hits. Data obtained from a precision registration may be used to construct an OF chart or to determine corrections to survey chart data. The 01-02 personnel and the forward observers use the same procedures for spotting as with their primary weapon.

(7) If a MET station is available, you should conduct your precision registration concurrent with the time of the MET in order to determine a VE.

(8) The survey party may locate targets accurately enough (within 0.1 meters) to use MET plus VE techniques in engagement as outlined in FM 640. The 14.5-mm tabular firing tables contain sufficient information plus sample problems to allow FDC personnel to work a MET as though they were working it for their primary weapon (weight of projectile cannot be determined accurately, so we do not attempt to apply that value). A propellant temperature correction can be applied if the powder thermometer is placed in the vicinity of the projectiles.

(9) High angle fire mission with one battery adjusting and massing the battalion can be conducted with very good results even when the wind is blowing 20 to 30 miles per hour. The 10m site factor on the GFT should be used to determine site. Do not attempt to fire at a quadrant elevation above 1250 mils since the round may not impact with the nose of the projectile in the downward position.

(10) The time of flight on the GFT and in the TFT is sufficiently accurate to permit battalion TOT missions to be fired. Battalion TOT targets should be selected near a lateral limit rather than in the center of sector, so as to allow different times of flight for each battery.

(11) Coordinated illumination missions may be fired by having the forward observer, or someone located in the vicinity of the OP, fire at the appropriate time either a hand-held, star-cluster parachute flare or a flare fired from the M79 grenade launcher. The flare will provide illumination over most of the impact area for about one minute. The call for fire should include "AT

MY COMMAND" allowing the observer to fire as soon as the target area is adequately illuminated. This may allow the observer to see the results of two corrections with one flare.

2-13. Preparation for Firing.

a. *Assembly and Installation.* Assemble or install the trainer or subcaliber device in accordance with applicable paragraphs 2-6 through 2-10.1)

NOTE

Trainer M31 will be positioned with the rear leg opposite the direction of fire.

b. *Boresighting.* The trainer or subcaliber device has been boresighted during assembly or installation. Recheck boresighting in accordance with applicable paragraphs (para. 2-6 through 2-10.1).

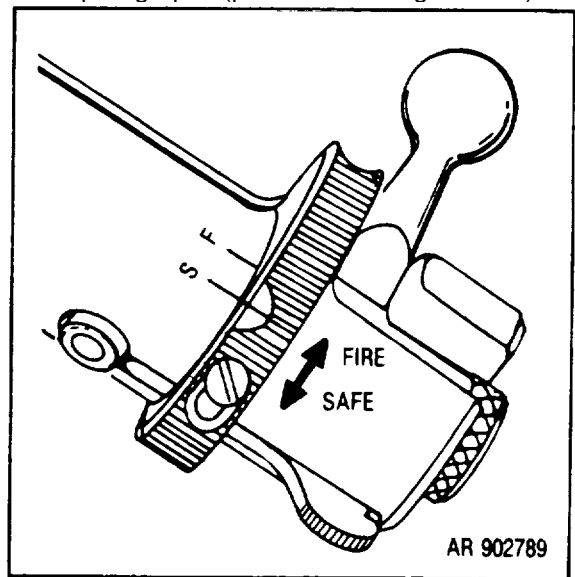

Figure 2-18. Operation of safety

2-14. Firing the Trainer.

a. *Loading.* Pull the breech bolt to the rear, and make sure the bore and chamber are dry and free of dirt and foreign matter. Place safety in the safe position, (fig. 2-18), insert a cartridge in the chamber and close the bolt.

b. *Firing.* Rotate safety to fire position. Depress the trigger by pulling the lanyard, or if lanyard ring assembly is not installed, by placing the thumb on the trigger and the forefinger on the opposite side of the receiver to prevent lateral movement of the barrel when trigger is depressed.

c. *Extraction.* Pull the bolt to the rear to eject the cartridge case. If the case fails to extract, use the cleaning rod to remove it; then follow instructions in table 3-2. If the adapter is installed in the breech recess of the major caliber weapon (e.g., 105-mm howitzer M102) it will have to be removed from the tube in order to push the cartridge case out with the cleaning rod. If the adapter is installed in place of the obturator spindle (e.g., 155-mm howitzer M114A1), it is only necessary to open the breechblock of the major caliber weapon.

d. *Misfire, Hangfire, and Cookoff*

(1) *Misfire.* A misfire is a complete failure to fire and may be due to a faulty firing mechanism or faulty element in the propelling charge explosive train. A misfire in itself is not dangerous, but since it cannot be immediately distinguished from a delay in the functioning of the firing mechanism or from a hangfire, these possibilities should be considered until they have been eliminated. Such delay in the functioning of the firing mechanism could result from the presence of foreign matter such as sand, grit, frost, and ice, or improper or excessive oil or grease. These conditions might create a partial mechanical restraint which, after some delay, is overcome as a result of the continued force applied by the spring, and the firing pin then driven into the primer in the normal manner. No cartridge should be left in a hot trainer or subcaliber device any longer than circumstances require because of the possibility of a cookoff.

(2) *Hangfire.* A hangfire is a delay in the functioning of a propelling charge at the time of firing. The amount of delay is unpredictable but, in most cases, will fall within the range of a split second to several minutes. A hangfire cannot immediately be distinguished from a misfire, and, therefore, it may be mistaken for a misfire. In case of a misfire, perform the following steps in sequence:

- (a) Keep the device trained on the target and all personnel clear of the muzzle.
- (b) Before attempting to remove the cartridge from the trainer, personnel not required for the operation will be cleared from the vicinity.
- (c) Inspect rear of bolt to determine if the firing pin has been released and is forward. (It will protrude from the rear of the bolt if the weapon is cocked). If the firing pin has been released, wait 30 seconds and proceed with steps d, e, and f.

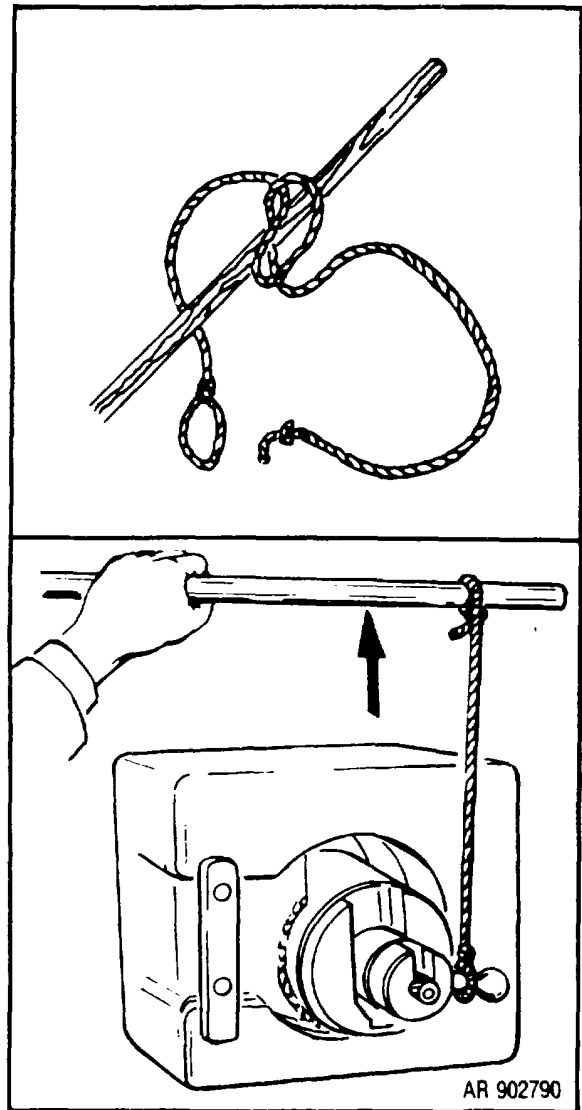

Figure 2-19. Misfire device

NOTE

You may have a hangfire. A hangfire cannot be distinguished from a misfire if the firing pin has been released. If the firing pin has not been released you can immediately proceed to steps d, e, and f.

- (d) Attach locally fabricated device, (figure 2-19) to breech bolt lever.
- (e) Pull bolt lever up, then to the rear and eject cartridge.
- (f) Inspect the cartridge from a distance to determine if the cartridge or firing mechanism is at fault. If the primer is dented, dispose of the cartridge in accordance with local regulations for small arms ammunition. If primer is not dented, disassemble the bolt and repair as necessary.

(3) *Cookoff*: A cookoff is a functioning of any or all of the components of a cartridge chambered in a very hot trainer due to the heat from the trainer. If the cartridge propellant should cookoff, the projectile will be propelled from the trainer with normal velocity even though no attempt was made to fire the primer by actuating the firing mechanism. In such case, there may be uncertainty as to whether or when the cartridge will fire, and precautions should be observed the same as those prescribed for hangfire. To prevent a cookoff, a cartridge which has been loaded into a very hot trainer should be fired immediately, or removed after a lapse of 5 seconds and within 10 seconds.

2-15. Services after Firing.

a. Immediately after firing and on two consecutive days thereafter, thoroughly clean the barrel

bore, receiver, breech bolt, and firing pin with lubricant and preservative cleaner (CLP), making certain that all surfaces are well coated. Do not wipe dry. On the third day after firing, clean with CLP, wipe dry (using clean lintfree cloth), and coat lightly with CLP.

b. Clean all exposed surfaces of the trainer, and lubricate in accordance with paragraph 3-4.

c. Disassemble the trainer in reverse sequence as indicated in paragraph 2-6, and replace in shipping and storage chest.

d. Remove subcaliber device in reverse order of applicable installation paragraph (see para. 2-7 through 2-10.1).

Section IV. OPERATION UNDER UNUSUAL CONDITIONS

2-16. General.

a. Operational procedures for the trainer or subcaliber device under unusual conditions are the same as under usual conditions (para. 2-12 through 2-15). Special instructions for servicing the trainer or subcaliber device under unusual conditions are contained herein. In addition to the normal preventive maintenance services, special care in cleaning must be observed where extremes of temperature, humidity, and atmospheric conditions are present or anticipated. Proper cleaning and handling guards against excessive wear and deterioration of the materiel. b. When chronic failure of materiel results from subjection to extreme conditions, report of such failure should be made in accordance with paragraph 1-2.

b. Protect the materiel when not in use. Keep snow and ice from the controls. Provide as much protection as possible.

c. When the materiel is brought from a cold temperature to a heated area, it should be wrapped in a covering of sufficient thickness to allow it to reach 'room temperature' gradually.

d. If a materiel is brought into a warm area and condensation forms, it must be thoroughly cleaned and dried as soon as it reaches room temperature. If materiel is taken into below freezing temperatures before it is thoroughly cleaned and dried, ice will form in its mechanisms, making it inoperative.

2-17. Operation in Cold Climates.

a. Special preparation of materiel scheduled for operation in extreme cold weather is necessary. Extreme cold will cause lubricants to thicken or congeal, which will impair operation of the trainer. Lubricate the materiel for operation in cold climates according to instructions in FM 9-207.

2-18. Operation in Hot Climates.

a. In hot climates, the film of oil necessary for operation and preservation will be quickly dissipated and should be renewed more frequently. Inspect the materiel more frequently, paying particular attention to hidden surfaces (the bore, receiver, and like places), where corrosion might occur and not be quickly noticed.

b. Perspiration is a contributing factor to rusting because it contains acids and salts. After handling, clean, wipe dry, and restore oil film.

Change 1 2-27/(2-28 blank)

CHAPTER 3
OPERATOR MAINTENANCE INSTRUCTIONS

Section I. REPAIR PARTS, SPECIAL TOOLS, AND EQUIPMENT

3-1. Repair Parts. Repair parts supplied to the operator are listed in appendix C, which is the authority for requisitioning replacements.

3-2. Special Tools and Equipment. There are no special tools or equipment required for repair of the trainer.

Section II. CLEANING AND LUBRICATION INSTRUCTIONS

3-3. General. These instructions are provided for the operating maintenance personnel to properly clean and lubricate the trainer (fig. 3-1).

and apply a light film of CLP. Extend and do the same for the hidden portion of the rear leg.

3-4. Cleaning and Lubrication.

(2) Place a few drops of CLP at the top and bottom of the leg adjusting sleeve between the sleeve and tripod legs; then rotate the adjusting sleeve to its maximum limits in both directions (red lines around the legs indicate the maximum limits).

a. Barrel Assembly. Weekly clean all exposed metal surfaces and apply a light film of CLP (fig. 3-1). Wipe the barrel bore, receiver, breech bolt, and firing pin dry before firing.

(3) Touch-up painted surfaces, as necessary.

b. Mount Assembly.

(1) Weekly clean all unpainted metal surfaces and apply a light film of CLP. Do not oil bronze components.

d. Telescope Socket, Holder and Support Assemblies. Weekly clean all unpainted metal surfaces and apply a light film of CLP. Place a few drops of CLP on the telescope lock and handle. Touch-up painted surfaces, as necessary.

(2) Monthly clean the bevel gears and elevating and traversing worm gears, and apply artillery and automotive grease (GAA).

(3) Touch-up painted surfaces, as necessary.

e. Adapter Assemblies. Weekly clean and apply a light film of CLP. After firing, clean the adapter bore using the same procedures prescribed for the barrel bore (fig. 3-1).

c. Tripod Mount Assembly.

(1) Weekly clean all exposed metal surfaces

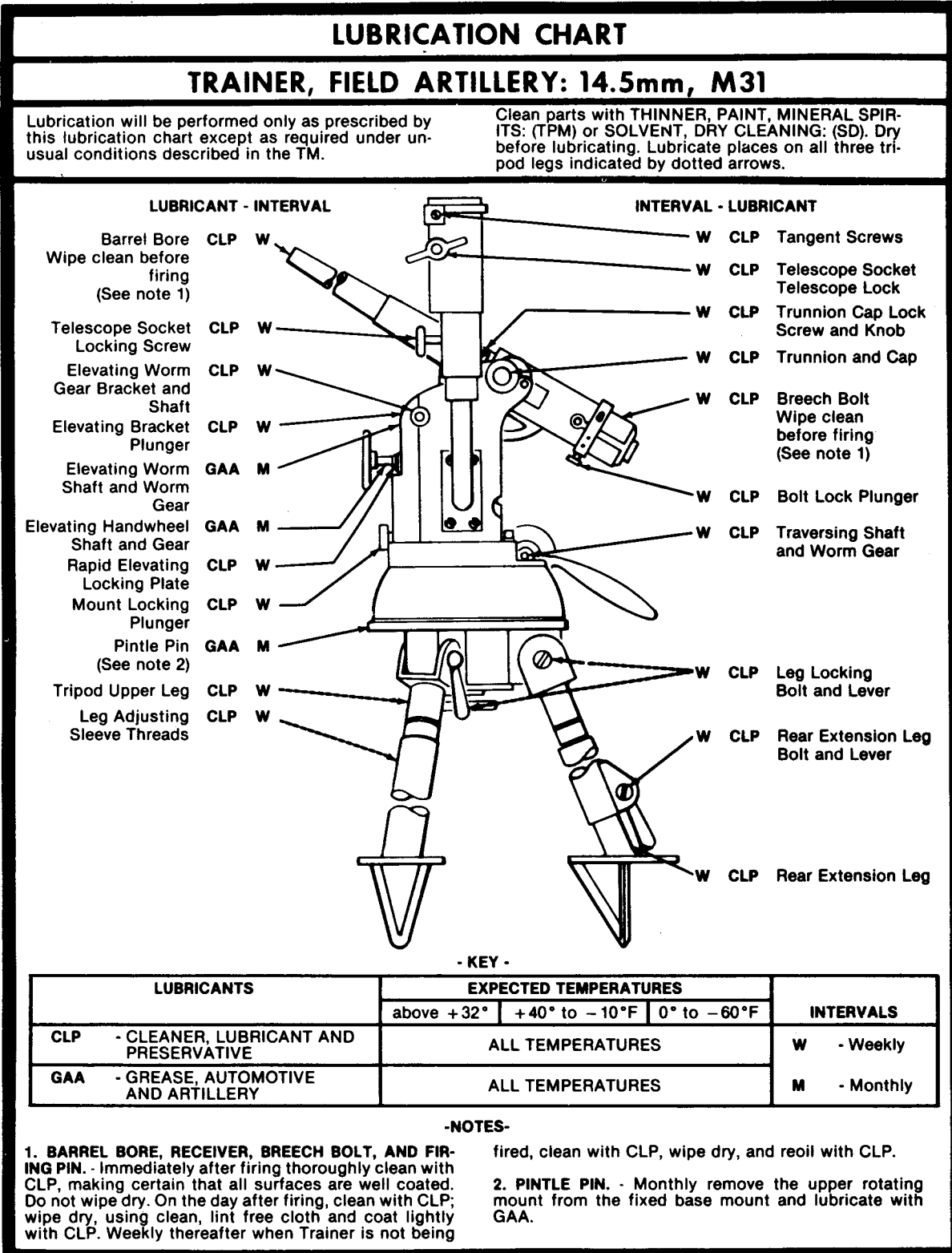

ARR 81-1843

Figure 3-1. Lubrication chart

Section III. PREVENTIVE MAINTENANCE CHECKS AND SERVICES

3-5. General.

a. To insure that the 14.5-mm field artillery trainer M31 or subcaliber device is ready for operation at all times, it must be inspected systematically so that defects may be discovered and corrected before they result in serious damage or failure. The necessary preventive maintenance checks and services to be performed are listed in table 3-1. Defects discovered during operation of the unit will be noted for future correction, to be made as soon as operation has ceased. Stop operation immediately if a deficiency is noted which would damage the equipment if operation were continued. All deficiencies and shortcomings will be recorded, together with the corrective action taken, on DA Form 2407 at the earliest opportunity. The frequency of the preventive maintenance services prescribed is considered a minimum requirement for operation of the materiel under usual conditions. Under unusual operating conditions, such as extreme temperatures,

dust or sand, extremely wet terrain, moist or salty atmosphere, or in rain or snow, it will be necessary to perform the maintenance services more frequently.

b. The general preventive maintenance services outlined below will be observed, in addition to those referred to in table 3-1.

(1) Check to see that the trainer is correctly assembled, and no parts or components are missing.

(2) Inspect for loose, broken, or damaged parts. Tighten loose parts.

(3) Each time the trainer is disassembled for cleaning or repair, carefully inspect all parts for cracks, excessive wear, rust, and like defects which might cause malfunctions. Clean all parts before assembly.

3-6. Operator's Preventive Maintenance The item or points to be inspected and serviced by the operators are listed in table 3-1.

Table 3-1. Preventive Maintenance Checks and Services

Item	B - Before firing			D - During firing	A - After firing
	Interval B	D	A	Procedure	Work time (M, H)
Barrel assembly	x	x	x	See that bolt lock plunger properly engages the breech bolt.	0.1
	x	x	x	Check bolt for smooth operation.	
	x	x	x	Check safety for proper operation.	
	x	x	x	Check trigger for proper functioning.	
Barrel	x			Insure that bore is free of all residue by use of bronze cleaning brush.	0.2
	x			Wipe bore clean and dry.	
		x		Clean barrel with bronze cleaning brush after each 15 cartridges.	
Mount assembly			x	Clean barrel.	0.1
	x	x	x	Insure that trunnion caps hold barrel assembly securely.	
	x			Check elevating handwheel for smooth operation.	
	x			Check traversing handwheel for smooth operation.	
	x			Check for broken level vials.	
	x			Insure that gears disengage properly for rapid elevating and traversing of trainer.	
Telescope socket assembly	x	x		Insure that mount assembly is mated to the tripod securely.	0.1
	x			Check telescope socket for secure retention of telescope socket assembly.	
Tripod mount assembly	x	x		Check leg locking levers. They must hold the legs securely in place.	0.1
	x	x		Check mount locking screw for secure retention of the mount assembly.	

Section IV. TROUBLESHOOTING

3-7. General. This section provides information useful in diagnosing and correcting unsatisfactory operation or failure of the trainer or subcaliber device which is peculiar to operator maintenance operations only. Malfunctions which may occur

are listed in table 3-2. Each malfunction stated is followed by a list of probable causes of the trouble. The corrective action is described opposite the probable cause.

Table 3-2. Troubleshooting

Malfunction	Probable cause	Corrective action
Failure to fire	Defective firing pin Weak firing pin compression helical spring Defective trigger	Replace firing pin. Replace spring. Replace trigger.
Failure to extract	Defective extractor Weak or broken extractor spring	Replace extractor. Replace spring.
Hard to elevate	Elevating gears out of adjustment	Adjust gears.
Jerky elevation	Burred or stripped gears	Notify direct support maintenance.
Jerky traverse	Burred or stripped gears	Notify direct support
Tripod legs bind	Bent legs	Notify direct support maintenance.

Section V. MAINTENANCE INSTRUCTIONS

3-8. General. Maintenance by the operator is confined to replacing the firing pin and firing pin compression helical spring (para. 3-9), cleaning and lubricating the trainer (para. 3-4), and preventive maintenance checks and services (table 3-1).

3-9. Maintenance of Firing Pin and Spring. To replace a damaged or broken firing pin or compression helical spring, perform the following steps in sequence:

Step 2: Remove the breech bolt screw, detent spacer, and bolt lever. The compression helical spring, spring guide, and firing pin will now slide out the rear of the bolt.

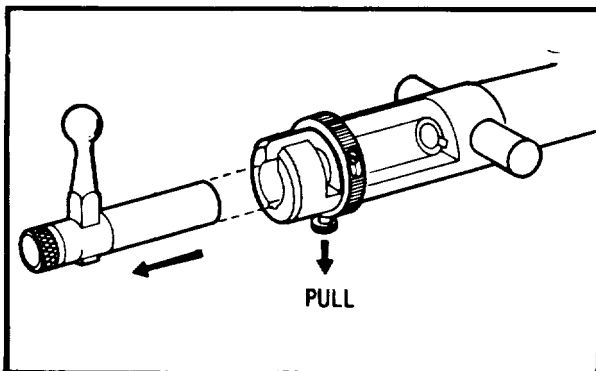

Step 1: Remove the bolt by pulling down on the bolt locking cap and pulling bolt to the rear.

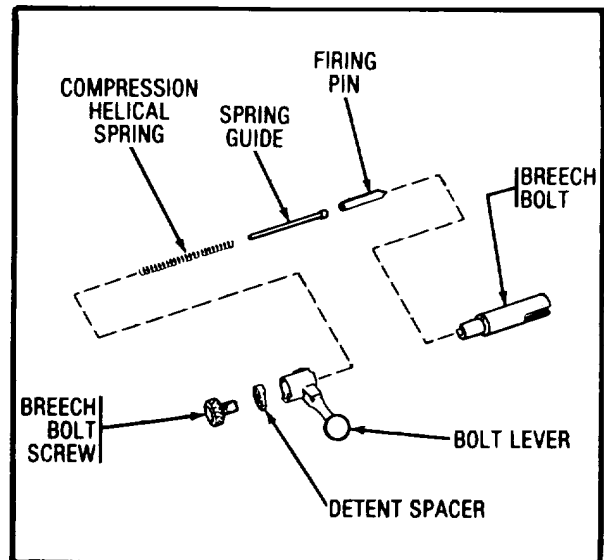

Step 3: Replace the spring and/or firing pin as required, then reassemble parts in reverse order.

**CHAPTER 4
ORGANIZATIONAL MAINTENANCE INSTRUCTIONS**

Section I. REPAIR PARTS, SPECIAL TOOLS, AND EQUIPMENT

4-1. Repair Parts. Repair parts supplied for organizational maintenance are listed in appendix C, which is the authority for requisitioning replacements.

4-2. Special Tools and Equipment. There are no special tools and equipment required for repair of the trainer.

Section II. PREVENTIVE MAINTENANCE CHECKS AND SERVICES

4-3. General. To insure that the 14.5-mm field artillery trainer M31 and subcaliber devices are ready for operation at all times, they must be inspected systematically so that defects may be discovered and corrected before they result in serious damage or failure. The necessary preventive maintenance checks and services to be performed are listed in table 4-1. The item numbers indicate the sequence of minimum inspection requirements. All deficiencies and shortcomings will be recorded, together with the corrective action taken, as required by DA PAM 738-750 (TAMMS).

4-4. Organizational Preventive Maintenance. Service by organizational maintenance personnel includes a systematic check to see that all operator's preventive maintenance has been properly performed at the prescribed intervals and that the materiel is in the best possible operating condition. The services outlined in table 4-1 are to be performed by organizational maintenance personnel at the designated intervals, in addition to any maintenance required as a result of the checks and services by the operator.

Table 4-1. Preventive Maintenance Checks and Services

Weekly	Item to be inspected	Procedure	Reference	Time standards
1	Barrel assembly		Para 3-4	0.2
X		Check all components for proper functioning	Para 4-7 and 4-8	
X		Replace cracked or broken parts, and weak springs		
2	Mount assembly		Para 4-9	0.1
X		Check all components for proper functioning		
3	Tripod mount assembly		Para 4-10	0.1
X		Check overall for proper functioning and for broken or missing parts		
4	Telescope socket, holder and support assemblies		Para 4-11	0.2
X		Replace tangent screws when worn or stripped		0.1
X		Replace telescope socket locking screws when worn or stripped		
5	Adapter assemblies		Para 4-12	0.1
X		Check overall for proper functioning and for broken or missing parts		
6	Tools and equipment			0.2
X		Replace all missing or broken items		

Section III. ORGANIZATIONAL

4-5. General. This section describes organizational maintenance for the 14.5-mm field artillery trainer M31 and subcaliber devices. Replacement of repair parts will be limited to those allocated in the maintenance allocation chart (app. B) and repair parts and special tools list (app. C). For troubleshooting see chapter 3.

4-6. Removal and Installation of Major Components. The major components of the trainer are contained in the shipping and storage chest. If necessary to remove components from assembled trainer, refer to paragraph 2-6. For assembly, refer to paragraph 2-6.

4-7. Maintenance of Breech Bolt Group.

a. Disassembly (Fig. 4-1).

(1) Remove breech bolt group from barrel receiver (para. 3-9).

(2) Disassemble the breech bolt group in accordance with figure 4-1.

b. Maintenance.

(1) Clean and oil the breech bolt group as indicated in the lubrication chart (fig. 3-1) and paragraph para 3-4.

(2) Remove corrosion, burs, or scored areas with crocus cloth.

(3) Replace damaged or broken parts. If either the bolt or breech bolt lever is unserviceable, notify direct support maintenance personnel.

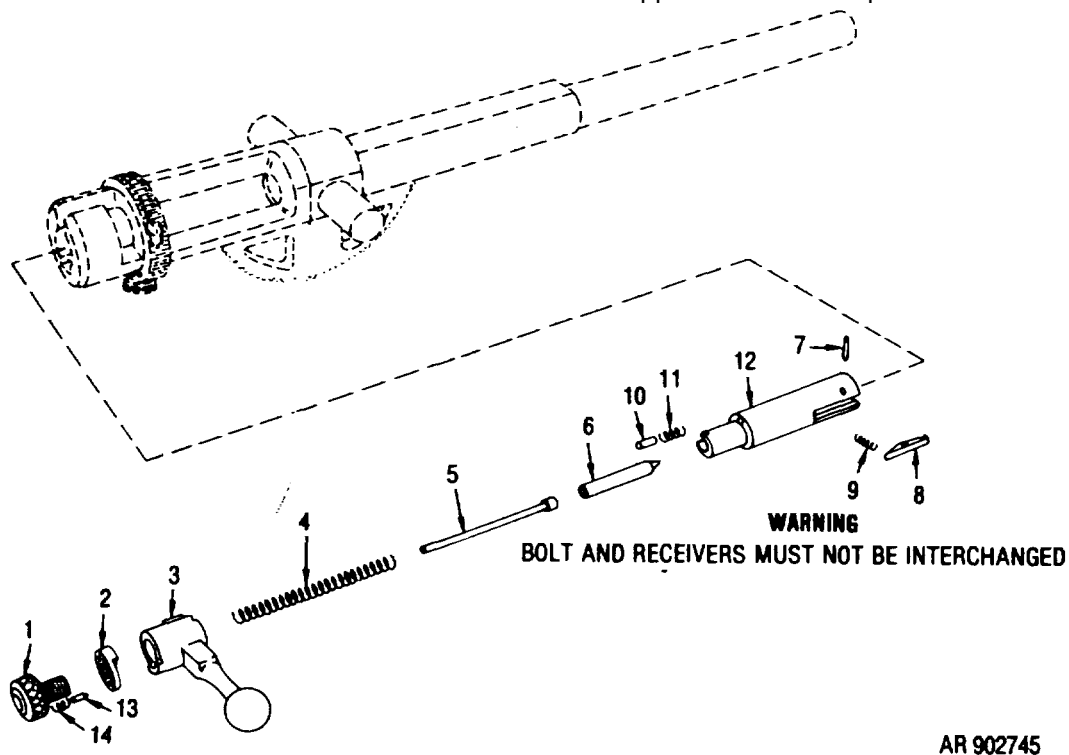

- | | |
|---------------------------------|----------------------------|
| 1. Bolt Screw - 11578612 | 8. Extractor - 11578608 |
| 2. Detent Spacer - 11578578 | 9. Extractor Spring |
| 3. Bolt Lever - 11578601 | 10. Plunger - 11578609 |
| 4. Firing Pin Spring - 11578613 | 11. Spring |
| 5. Spring Guide - 11578610 | 12. Breech Bolt - 11578600 |
| 6. Firing Pin - 11578606 | 13. Plunger - 11578611 |
| 7. Extractor Pin - 11578631 | 14. Bolt Spring |

Figure 4-1. Disassembly/assembly of breech bolt group

c. Assembly.

(1) Assemble the breech bolt group in accordance with figure 4-1.

(2) Install the breech bolt group into the barrel receiver.

(2) Remove corrosion, burs, or scored areas with crocus cloth.

(3) Replace damaged or broken parts. If the safety is unserviceable, notify direct support maintenance personnel.

4-8. Maintenance of Barrel Assembly.

a. Disassembly (Fig. 4-2).

(1) Remove the breech bolt group from barrel receiver (para. 3-9).

(2) Disassemble the barrel assembly in accordance with figure 4-2.

b. Maintenance.

(1) Clean and oil the barrel assembly as indicated in the lubrication chart (fig. 3-1) and subparagraph 3-4.

c. Assembly.

(1) Assemble the barrel assembly in accordance with figure 4-2.

(2) Install the breech bolt group into the barrel receiver.

NOTE

Be sure to assemble the bolt guide (15, fig. 4-2) with the beveled side on the bottom towards the muzzle of barrel.

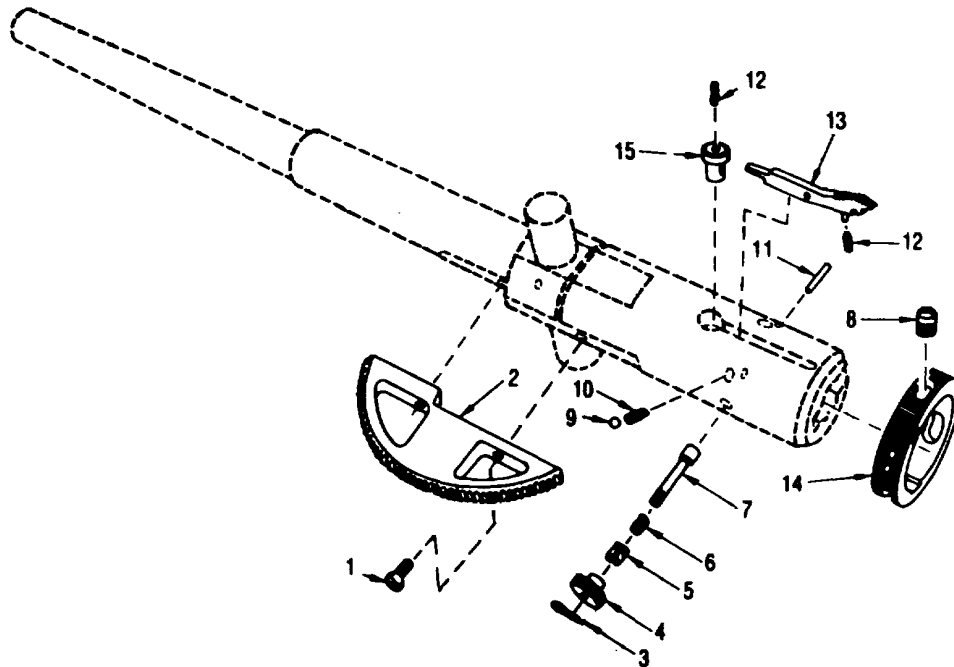

Legend

- | | |
|----------------------------|----------------------------|
| 1. Screw - 11578764 | 9. Bearing Ball - 11578632 |
| 2. Gear Sector - 11578695 | 10. Lock Spring |
| 3. Cotter Pin | 11. Trigger Pin - 11578630 |
| 4. Lock Knob - 11578617 | 12. Compression Spring |
| 5. Lock Bushing - 11578623 | 13. Trigger - 11578628 |
| 6. Lock Spring | 14. Safety - 11578607 |
| 7. Lock Plunger - 11578624 | 15. Bolt Guide - 11578604 |
| 8. Stop Screw - 11578622 | |

AR 902727

Figure 4-2. Disassembly/assembly of barrel assembly

4-9. Maintenance of Mount Assembly.

- a. Clean and oil the mount as indicated in the lubrication chart (fig. 3-1) and subparagraph 3-4.
- b. Remove corrosion, burs, or scored areas with crocus cloth.

4-10. Maintenance of Tripod Mount Assembly.

- a. Clean and oil the tripod mount assembly as indicated in the lubrication chart (fig. 3-1) and subparagraph 3-4.
- b. Replace the guide screw nut (1, fig. 4-3) and guide screw (2, fig. 4-3), if worn or threads are damaged.

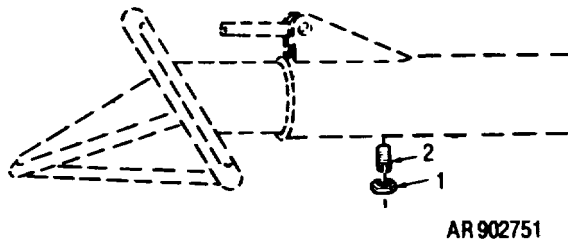

- Legend
 1. Guide Nut 11578712
 2. Guide Screw 11578711

Figure 4-3. Removal/installation of guide nut and screw from/to tripod rear leg

4-11. Maintenance of Telescope Socket, Holder, and Support Assemblies.

- a. Clean and oil the telescope socket, holder, or support assembly as indicated in paragraph 3-4.
- b. Replace damaged locking screw (1, fig. 4-4) in the telescope socket, holder, or support assembly in accordance with figure 4-4 (telescope socket shown).
- c. Loosen setscrew and replace tangent screw (2, fig. 44) if damaged.

4-12. Maintenance of Adapter Assemblies.

- a. Adapter Assemblies (PN1178866 and PN 11578873) for 10-mm Howitzer M1101A1.
 - (1) Disassemble in accordance with figure 4-

- 5.
 - (2) Clean and lubricate in accordance with paragraph 3-4.
 - (3) Replace or repair broken or damaged parts.
 - (4) Assemble in accordance with figure 4-5.
- b. Adapter Assemblies (PN 11578750 and PN 11678967) for 105-mm Howitzer M102.
 - (1) Disassemble in accordance with figure 4-6
 - (2) Clean and lubricate in accordance with paragraph 3-4.

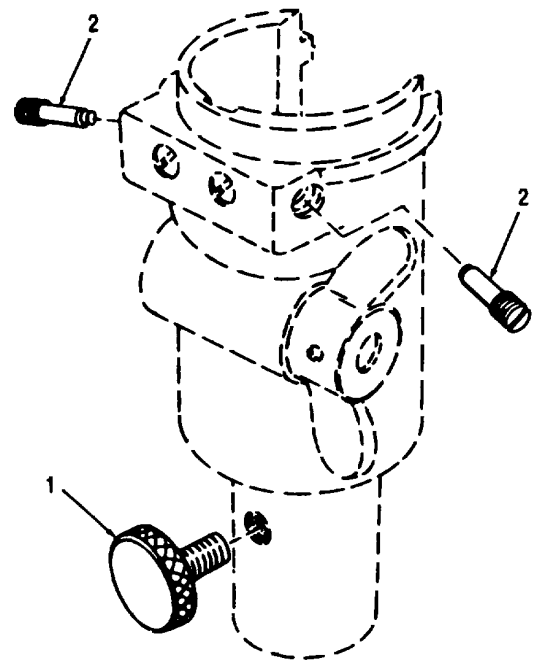

- Legend
 1. Locking Screw 11578705
 2. Tangent Screw 11578698

Figure 4-4. Removal/installation of telescope lock and tangent screws from/to telescope socket

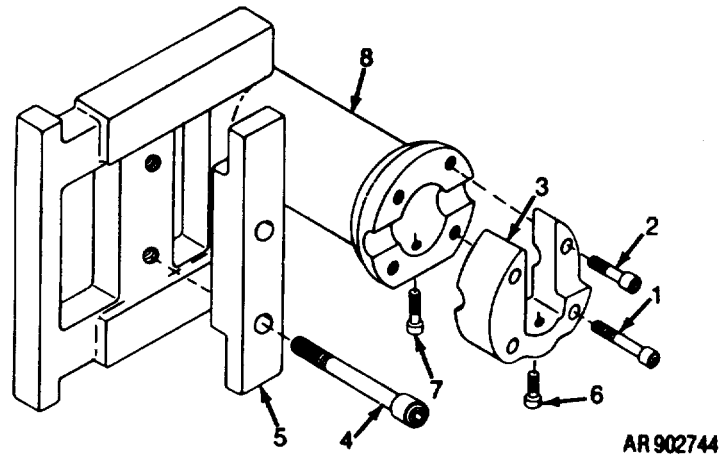

Legend

- | | |
|-------------------|----------------------------|
| 1. Screw | 5. Locking Bar - 11578839 |
| 2. Screw | 6. Screw |
| 3. Cap - 11578778 | 7. Screw |
| 4. Screw | 8. Adapter Body - 11578838 |

Figure 4-5. Disassembly/assembly of adapter assembly PN 11578865 for M101A1

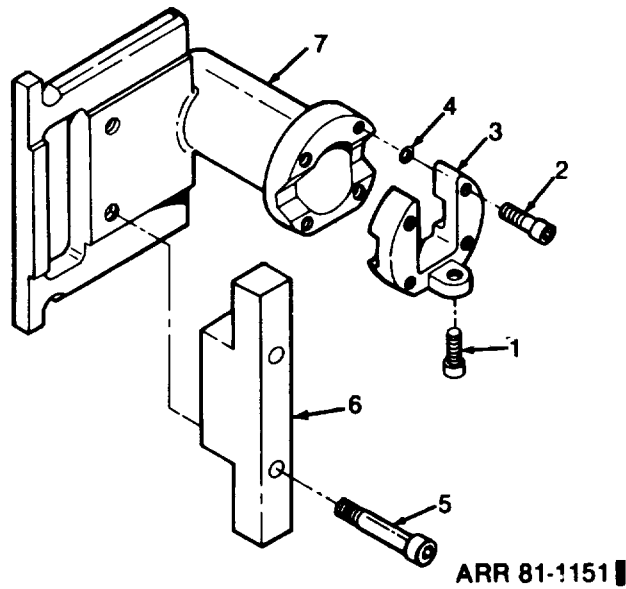

Legend

- | | |
|--------------------------------------|----------------------------|
| 1. Screw | 5. Screw |
| 2. Screw | 6. Locking Bar - 11578866 |
| 3. Cap - 11578868 | 7. Adapter Body - 11578865 |
| 4. Ring (Screw Retaining) - 11578950 | |

Figure 4-5A. Disassembly/assembly of adapter assembly PN 11578873 for M101A1

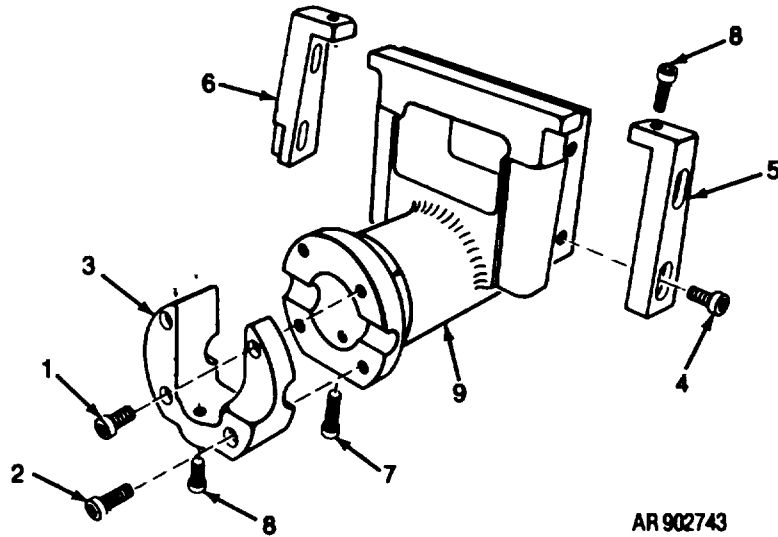

Legend

- | | |
|---------------------------|----------------------------|
| 1. Socket Head Cap Screw | 6. Left Gib - 11578777-2 |
| 2. Socket Head Cap Screw | 7. Socket Head Cap Screw |
| 3. Cap - 11578778 | 8. Socket Head Cap Screw |
| 4. Socket Head Cap Screw | 9. Adapter Body - 11578776 |
| 5. Right Gib - 11578777-1 | |

Figure 4-6. Disassembly/assembly of adapter assembly PN 11578750 for M102

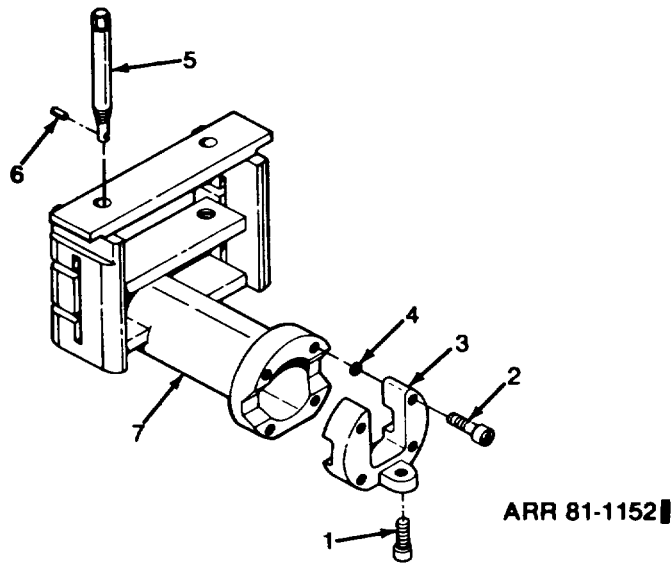

Legend

- | | |
|--------------------|----------------------------|
| 1. Screw | 5. Screw, Lock - 11578969 |
| 2. Screw | 6. Pin |
| 3. Cap - 11578868 | 7. Adapter Body - 11578968 |
| 4. Ring - 11578950 | |

Figure 4-6A. Disassembly/assembly of adapter assembly PN 11578967 for M102

(3) Replace or repair broken or damaged parts.

(4) Assemble in accordance with figure 4-6.

c. Adapter Assemblies (PN 11578752 and PN 11578876) for 155-mm Howitzer M114 and M114A1.

(1) Disassemble in accordance with figure 4-7.

(2) Clean and lubricate in accordance with paragraph 34.

(3) Replace or repair broken or damaged parts.

(4) Assemble in accordance with figure 4-7

d. Adapter Assemblies (PN 11578867 and PN 1578870) for 155mm Howitzer M109, 175mm Gun M107, and 8-inch Howitzer M110.

(1) Disassemble in accordance with figure 4-8.

(2) Clean and lubricate in accordance with paragraph 3-4.

(3) Replace or repair broken or damaged parts.

(4) Assemble in accordance with figure 4-8.

e. Adapter Assembly (PN 11579605) for 155mm Howitzer M198.

(1) Disassemble in accordance with figure 4-8

(2) Clean and lubricate in accordance with paragraph 3-4.

(3) Replace or repair broken or damaged parts.

(4) Assemble in accordance with figure 4-8

4-13. Maintenance of Lanyard Ring Assembly.

a. Disassemble in accordance with figure 4-9.

b. Clean and lubricate in accordance with paragraph 3-4.

c. Replace or repair broken or damaged parts.

d. Assemble in accordance with figure 4-9.

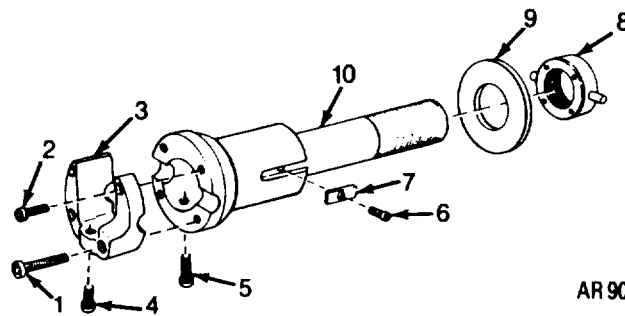

AR902741

Legend

- | | |
|--------------------------|-----------------------------|
| 1. Socket Head Cap Screw | 6. Socket Head Cap Screw |
| 2. Socket Head Cap Screw | 7. Key - 11578836 |
| 3. Cap- 11578718 | 8. Nut Assembly - 11578834 |
| 4. Socket Head Cap Screw | 9. Washer - 11578837 |
| 5. Socket Head Cap Screw | 10. Adapter Body - 11578835 |

Figure 4-7. Disassembly/assembly of adapter assembly PN 11578752 for M114 and M114A1

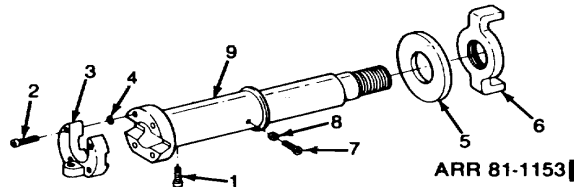

ARR 81-1153

Legend

- | | |
|--------------------------------------|----------------------------|
| 1. Screw | 6. Nut |
| 2. Screw | 7. Screw (Modified) |
| 3. Cap-11578868 | 8. Jam Nut |
| 4. Ring (Screw Retaining) - 11578950 | 9. Adapter Body - 11678877 |
| 5. Washer | |

Figure 4-7A. Disassembly/assembly of adapter assembly PN 11578876 for M114A1

Change 1 4-7

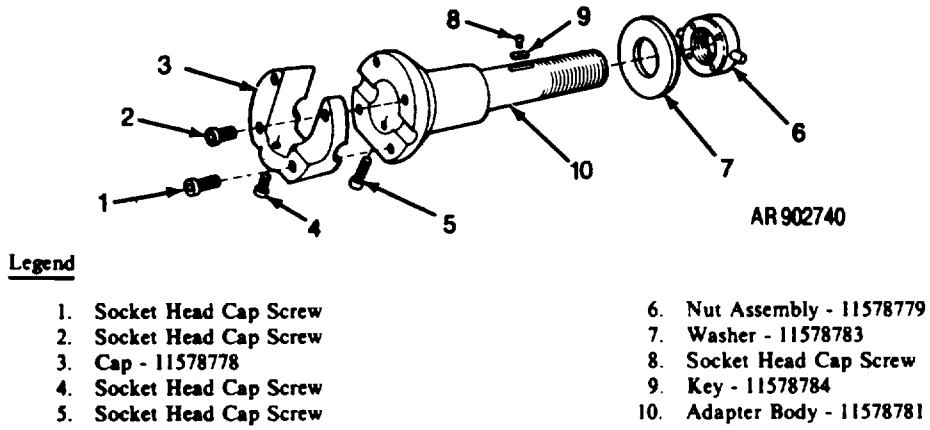

Figure 4-8. Disassembly/assembly of adapter assembly PN 11578780 for M109 series and M107/M110

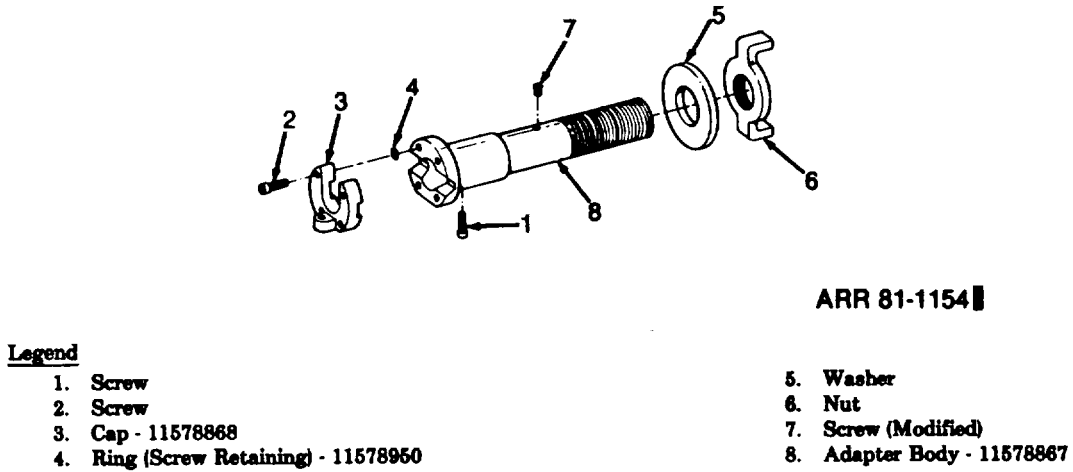

Figure 4-8A. Disassembly/assembly of adapter assembly PN 11578870 for M109/M109A1/M110

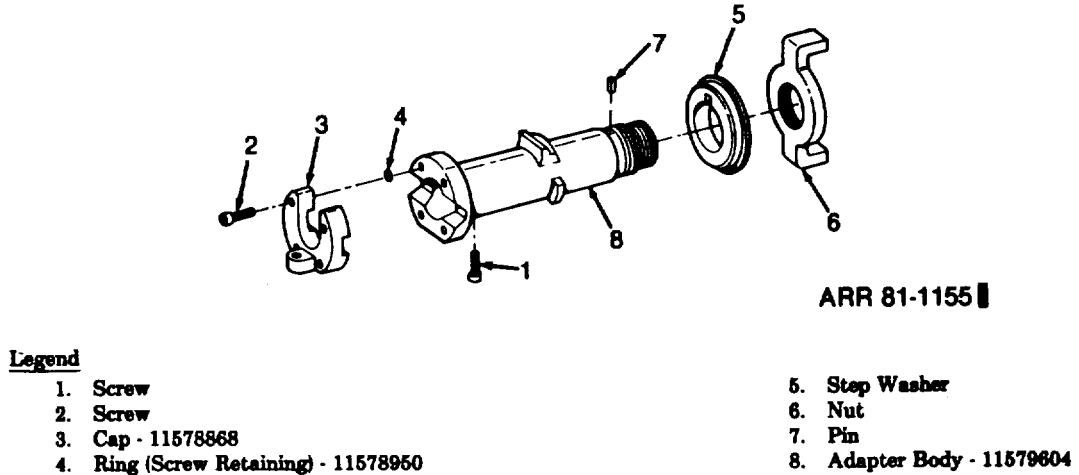
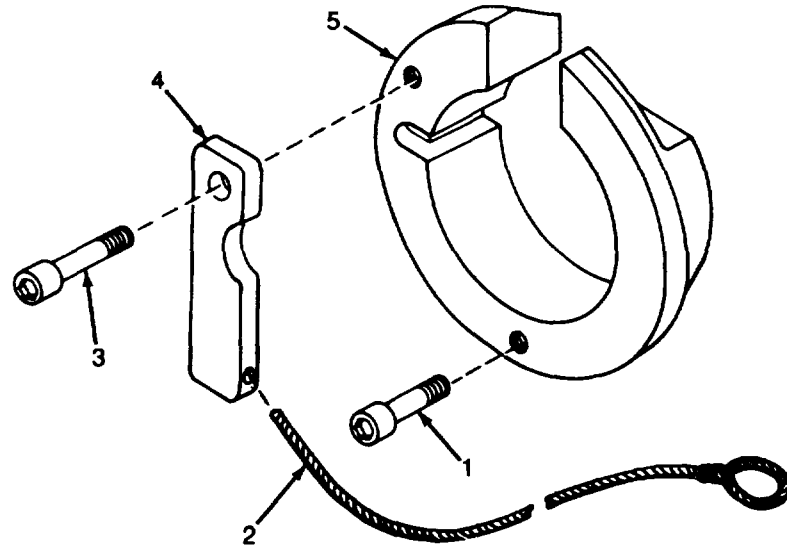

Figure 4-8B. Disassembly/assembly of adapter assembly PN 116796056 for M198



AR 902739

Legend

- 1. Screw
- 2. Lanyard - 11578774
- 3. Screw

- 4. Lever - 11578773
- 5. Holder - 11578771

Figure 4-9. Lanyard ring assembly - exploded view

Change 1 4-8.1/(4-8.2 blank)

CHAPTER 5

DIRECT SUPPORT MAINTENANCE INSTRUCTIONS

Section I. REPAIR PARTS, SPECIAL TOOLS, AND EQUIPMENT

5-1. Repair Parts. Repair parts supplied for direct support maintenance are listed in appendix C, which is the authority for requisitioning replacements.

5-2. Special Tools and Equipment. The head-space gage P/N 11578863 required for inspection of the trainer is illustrated in figure 5-1 and its use is illustrated in figure 5-2.

5-3. Consumable Supplies. Consumable supplies normally required in performing assembly and repair operations are listed in table 5-1.

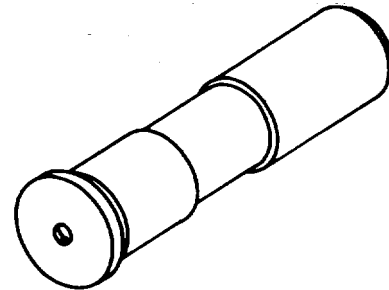

AR 902756

Figure 5-1. Headspace gage

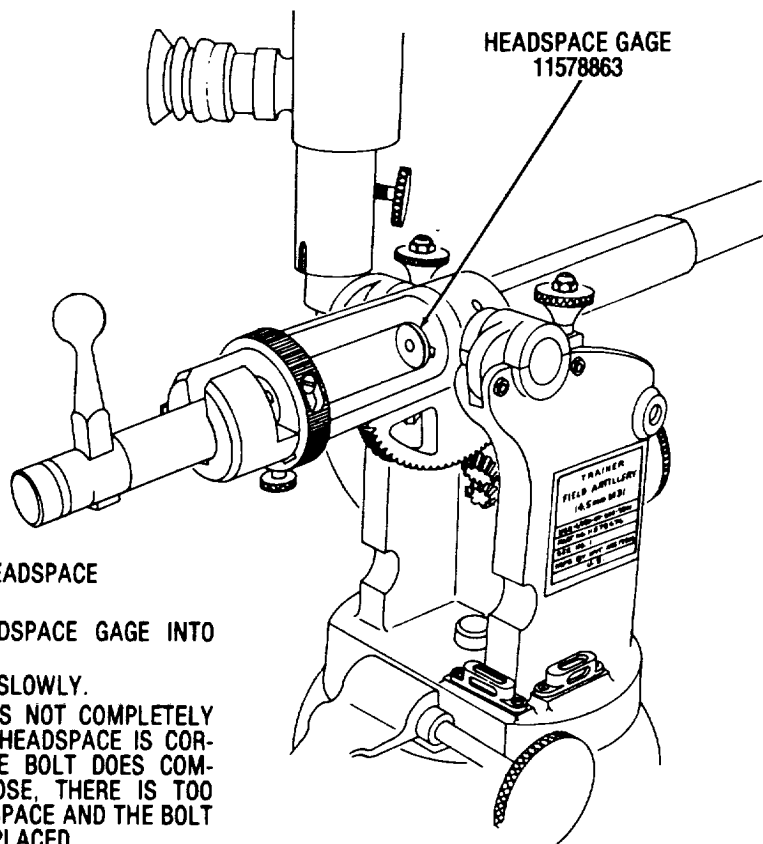

- CHECKING HEADSPACE**
- STEP 1: OPEN BOLT.
 - STEP 2: INSERT HEADSPACE GAGE INTO BREECH.
 - STEP 3: CLOSE BOLT SLOWLY.
 - STEP 4: IF BOLT DOES NOT COMPLETELY CLOSE, THE HEADSPACE IS CORRECT. IF THE BOLT DOES COMPLETELY CLOSE, THERE IS TOO MUCH HEADSPACE AND THE BOLT MUST BE REPLACED.

AR 902757

Figure 5-2. Checking headspace

Table 5-1. Consumable Supplies

NSN	Description
	GREASE, AIRCRAFT AND INSTRUMENT: MIL-G-23827
9150-00-985-7245	8 oz tube
9150-00-985-7246	1 lb can
9150-00-985-7247	5 lb can
9150-00-985-7248	35 lb pail
	GREASE, AUTOMOTIVE AND ARTILLERY: MIL-G-10924
9150-00-190-0904	1 lb can
9150-00-190-0905	55 lb can
9150-00-190-0907	35 lb pail
	GREASE, GRAPHITE SOFT: grade 1, V-G 671
9150-00-190-0917	1 lb can
9150-00-190-0919	5 lb can
	GREASE, MOLYBDENUM DISULFIDE: liquid, MIL-G-21164
9150-00-935-4018	14 oz cartridge
9150-00-754-2595	1 lb can
9150-00-223-4004	5 lb can

Section II. TROUBLESHOOTING

5-4. General. This section provides information useful in diagnosing and correcting unsatisfactory operation or failure of the trainer or subcaliber device which is peculiar to direct support maintenance operation only. Malfunctions which may occur are listed in table 5-2.

Each malfunction stated is followed by a list of probable causes of the trouble. The corrective action recommended is described opposite the probable cause. For troubleshooting procedures performed by lower levels of maintenance, refer to tables 3-2 and 4-1.

Table 5-2. Troubleshooting

Malfunction	Probable cause	Corrective action
Breech bolt does not slide smoothly	Bolt damaged or burred	Remove burs or replace breech bolt.
Safety inoperative	Safety detent ball bearing damaged	Replace ball bearing.
	Safety detent ball bearing spring weak	Replace spring.
Failure to elevate	Barrel trunnion damaged or bent	Replace barrel trunnion and receiver assembly.
	Elevating bevel gear or worm gear stripped or burred	Remove burs or replace gears.
	Elevating bracket shaft bent	Replace shaft.
	Elevating worm gear bracket worn or damaged	Replace bracket.
Failure to traverse	Traversing worm gear or worm wheel gear stripped or burred	Remove burs or replace gears.
	Traversing shaft bent	Replace shaft.
	Rapid traverse lever damaged	Replace lever.
Rapid traverse lever fails to lock in place.	Broken torsion helical spring	Replace spring.

Section III. INSPECTION

5-5. General.

WARNING

Before starting an inspection, be sure to clear the trainer or subcaliber device. Do not actuate the firing mechanism until the weapon has been cleared. Inspect the receiver to insure that it is empty and check to see that no ammunition is in position to be introduced. Avoid having live ammunition in the vicinity of the work.

a. Check to see that trainer has been cleaned of all corrosion-preventive compound, grease, excessive oil, dirt, or foreign matter which might interfere with proper functioning or obscure the true condition of the parts.

b. Make an overall inspection of the weapon for general appearance, condition, operation, and manual functioning.

5-6. Categories of Inspection. The two categories of inspection are: (1) Inspection of materiel in the hands of troops, and (2) Direct support maintenance inspection. Direct support maintenance inspections are listed below.

Inspection	Explanation
Initial	Perform initial inspection of materiel received in maintenance support shops to determine materiel serviceability and required maintenance.
In-process	Perform in-process inspection during repair or overhaul to insure materiel conforms to maintainability standards.

5-3(5-4 blank)

CHAPTER 6 DIRECT SUPPORT MAINTENANCE REPAIR INSTRUCTIONS

Section I. GENERAL MAINTENANCE

6-1. General.

a. This section contains those procedures which are of a general nature. Reference will be made to pertinent paragraphs in this section in the repair sections, in order to eliminate constant repetition of general instructions. Special reclamation instructions are contained in pertinent repair paragraphs.

b. In sections II through V, major assemblies are disassembled, repaired, overhauled, replaced, assembled, and given a final inspection. These instructions are supplementary to instructions for operator and organizational maintenance, which are covered in preceding chapters.

6-2. Disassembly and Assembly Procedures.

a. In disassembling an assembly, remove the major subassemblies, whenever possible. Subassemblies may then be disassembled, as necessary, into individual parts.

b. During assembly, subassemblies should be assembled first and then installed to form a complete assembly. Lubricate parts that are normally lubricated with aircraft and instrument grease (GL) before assembly.

c. Complete disassembly of an assembly is not always necessary in order to make a required repair or replacement. Good judgment should be exercised to keep assembly and disassembly operations to a minimum.

d. Maintenance functions to be performed are outlined in appendix B. Disassembly will follow numerical sequence in the illustrations, assembly will follow reverse order of numerical sequence in the illustrations.

6-3. Replacement of Parts.

a. Replace all damaged screws, nuts, pins, or snap rings.

b. Replace all springs, if they are broken, kinked, bent, if they fail to function properly, or if they fail to meet

specific requirements.

c. If a required new part is not available, a reconditioned used part may be substituted. Such reconditioned used parts should approximate the finish of corresponding new parts. Allowable tolerances must not be exceeded. Remove all burrs and rough spots with a fine stone or crocus cloth.

d. Redrilling and filing of all replacement parts, except bolts, is permitted to obtain proper fit.

6-4. Use of Tools.

a. Care must be exercised to use tools that fit and are suitable for the task to be performed, in order to avoid unnecessary mutilation of parts and/or damage to tools.

b. Keep tools clean and work with clean parts. The rules of good housekeeping must be observed.

6-5. Welding. Refer to TM 9-237.

6-6. Repairing Damaged Threads. Repair damaged threads with a thread restorer or by chasing on a lathe.

6-7. Painting. Refer to TM 43-0139.

6-8. Cleaning. Refer to TM 9-208-1 and 9-208-2.

6-9. Finished Surfaces. All painted or treated surfaces will be refinished to match the appearance of new parts as outlined below.

a. Paint all surfaces on which paint has deteriorated or become damaged.

b. Do not paint working parts inside groups or mechanisms. Lightly lubricate such components in accordance with paragraph 3-4.

c. Do not paint polished machine-finished surfaces.

6-10. Lubrication. Refer to paragraph 3-4.

Section II. MAINTENANCE OF THE BOLT ASSEMBLY

6-11. Initial Inspection. Check headspace in accordance with figure 5-2.

6-12. Disassembly. Disassemble the bolt assembly in accordance with figure 6-1.

6-13. Cleaning, Inspection, and Repair.

a. **Cleaning.** Refer to paragraph 6-8.

b. **Inspection.** Refer to paragraphs 5-4 and 5-5.

c. **Repair.** Replace the bolt or operating handle if damaged. Check headspace (fig. 5-2) if bolt is replaced.

6-14. Assembly. Assemble the bolt assembly in accordance with figure 6-1.

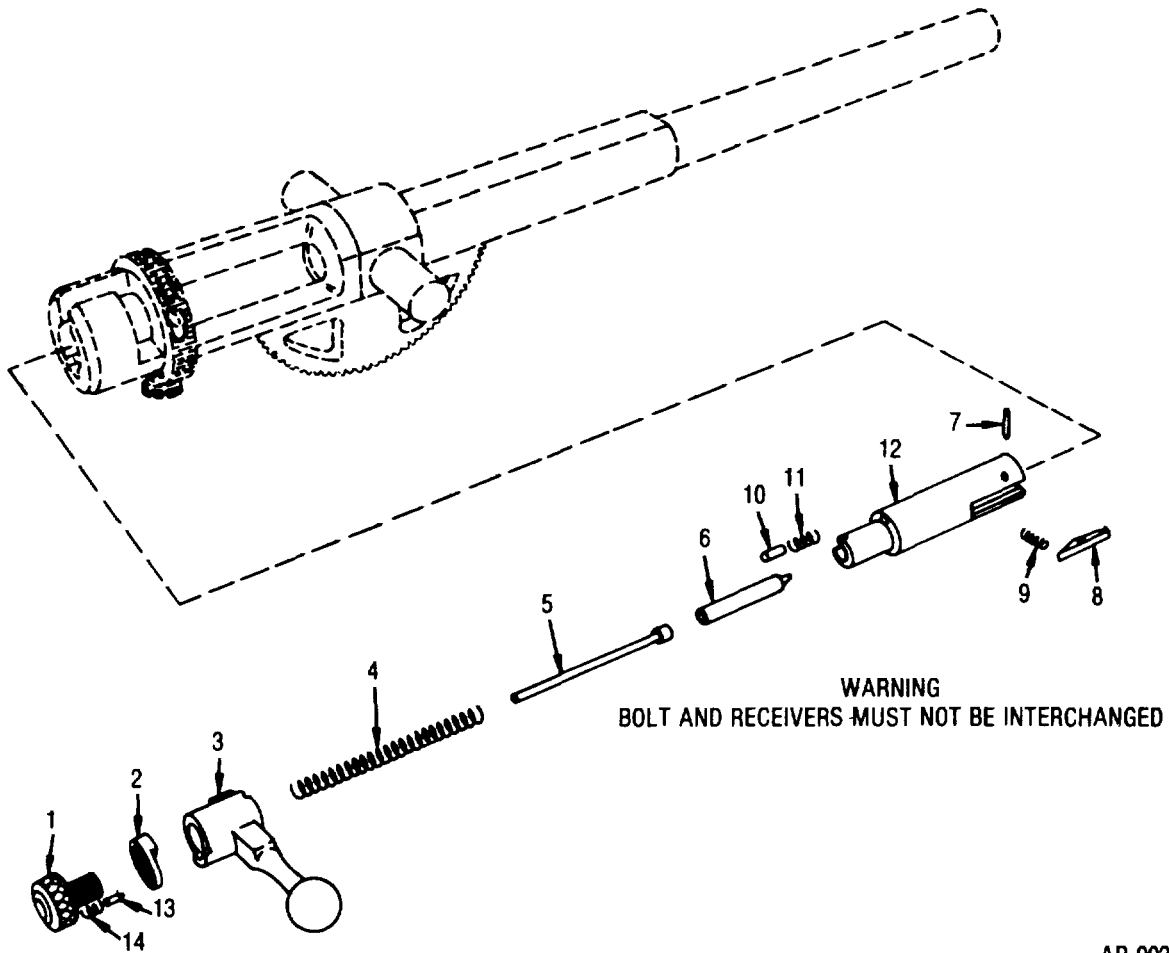

AR 902758

Legend

- | | |
|-----------------------------|----------------------------|
| 1. Screw - 11578612 | 8. Extractor - 11578608 |
| 2. Spacer - 11578578 | 9. Extractor Spring |
| 3. Lever - 11578601 | 10. Plunger - 11578609 |
| 4. Spring - 11578613 | 11. Plunger Spring |
| 5. Guide - 11578610 | 12. Breech Bolt - 11578600 |
| 6. Firing Pin - 11578606 | 13. Plunger - 11578611 |
| 7. Extractor Pin - 11578631 | 14. Spring |

Figure 6-1. Disassembly/assembly of breech bolt assembly

Section III. MAINTENANCE OF THE MOUNT ASSEMBLY

6-15. Disassembly. Disassemble the mount assembly as shown in figures 6-2 through 6-9.

c. *Repair.* Refer to paragraph 6-3.

6-16. Cleaning, Inspection, and Repair.

6-17. Assembly. Assemble the mount assembly in accordance with figures 6-2 through 6-9.

a. *Cleaning.* Refer to paragraph 6-8.

b. *Inspection.* Refer to paragraphs 5-4 and 5-5.

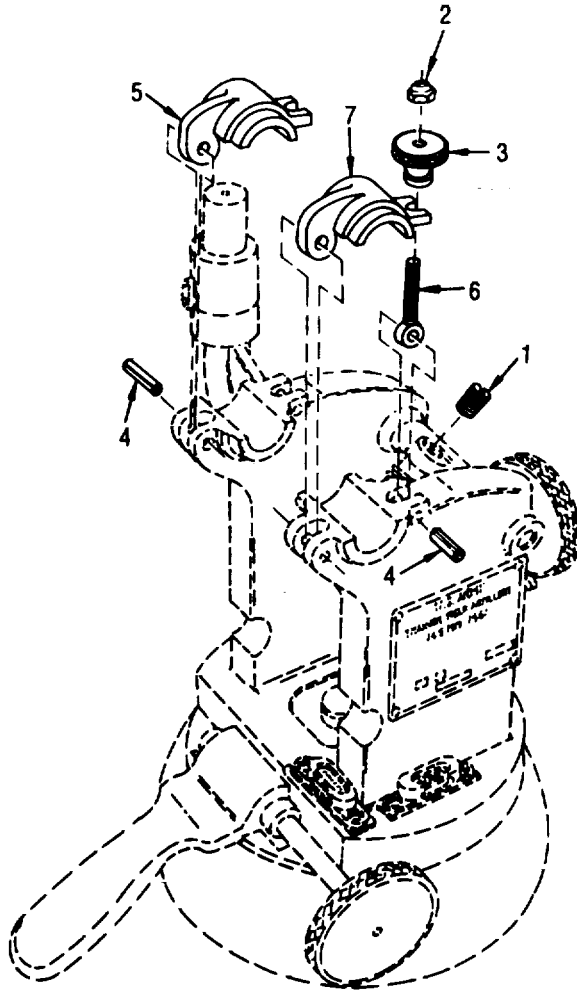

FILE CONCAVE SURFACE OR REPLACEMENT TRUNNION CAPS UNTIL CANNON WILL ELEVATE AND DEPRESS WITHOUT BINDING.

ADJUST SCREW (1) UNTIL ELEVATING GROUP OPERATES FREELY WITHOUT ENDPLAY BEFORE TIGHTENING SETSCREW.

AR 902747

Legend

- | | |
|-------------------------------|---------------------------------|
| 1. Adjusting Screw - 11578657 | 5. L.H. Trunnion Cap - 11578646 |
| 2. Stopnut - 11578678 | 6. Lock Screw - 11578638 |
| 3. Lock Knob - 11578640 | 7. R.H. Trunnion Cap - 11578647 |
| 4. Spring Pin - 11578645 | |

Figure 6-2. Removal/ installation of LH. and R.H. trunnion caps

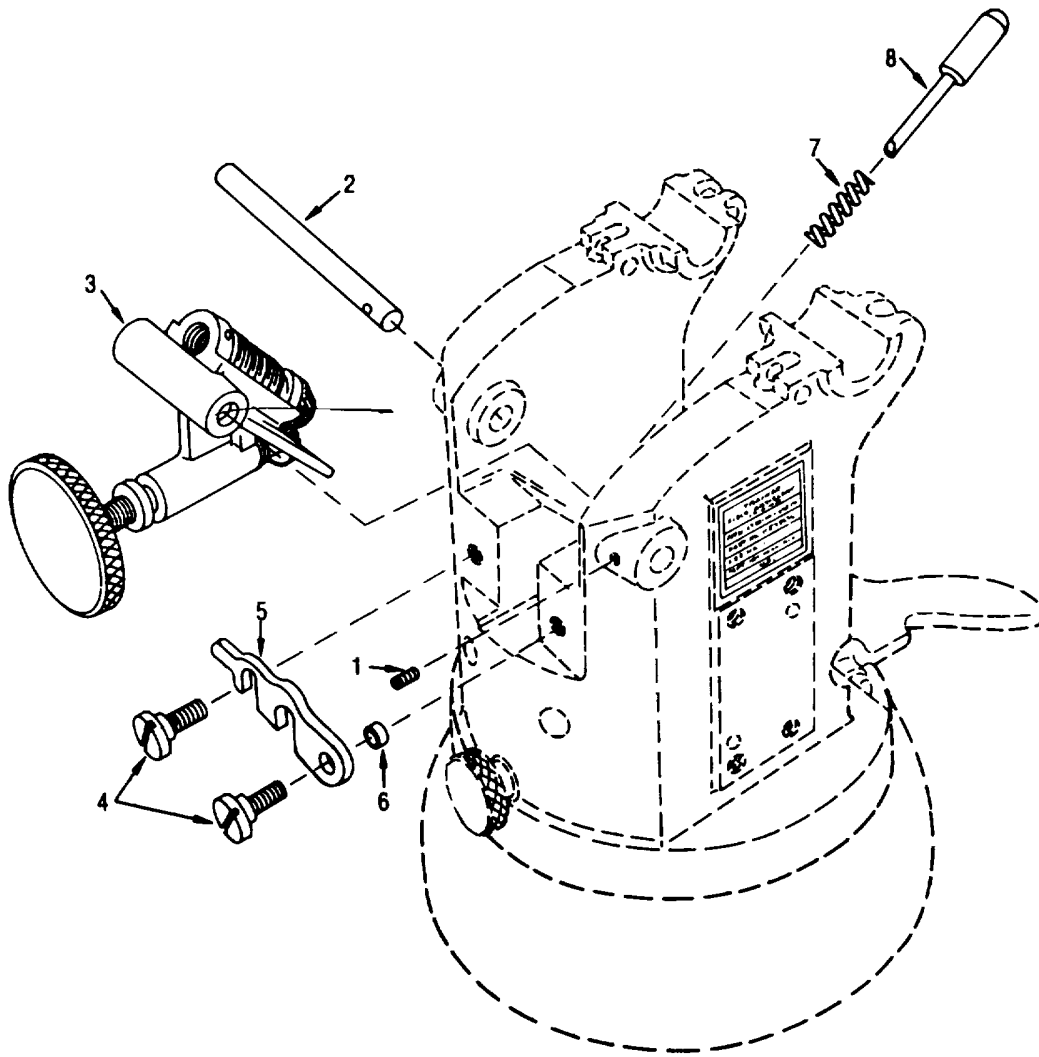

AR 902730

Legend

- | | |
|--------------------------------|-------------------------------|
| 1. Shaft Setscrew - 11578669 | 5. Locking Plate - 11578648 |
| 2. Bracket Shaft - 11578655 | 6. Locking Sleeve - 11578713 |
| 3. Bracket Assembly - 11578754 | 7. Spring |
| 4. Locking Screw - 11578636 | 8. Bracket Plunger - 11578649 |

Figure 6-3. Replacing elevation group

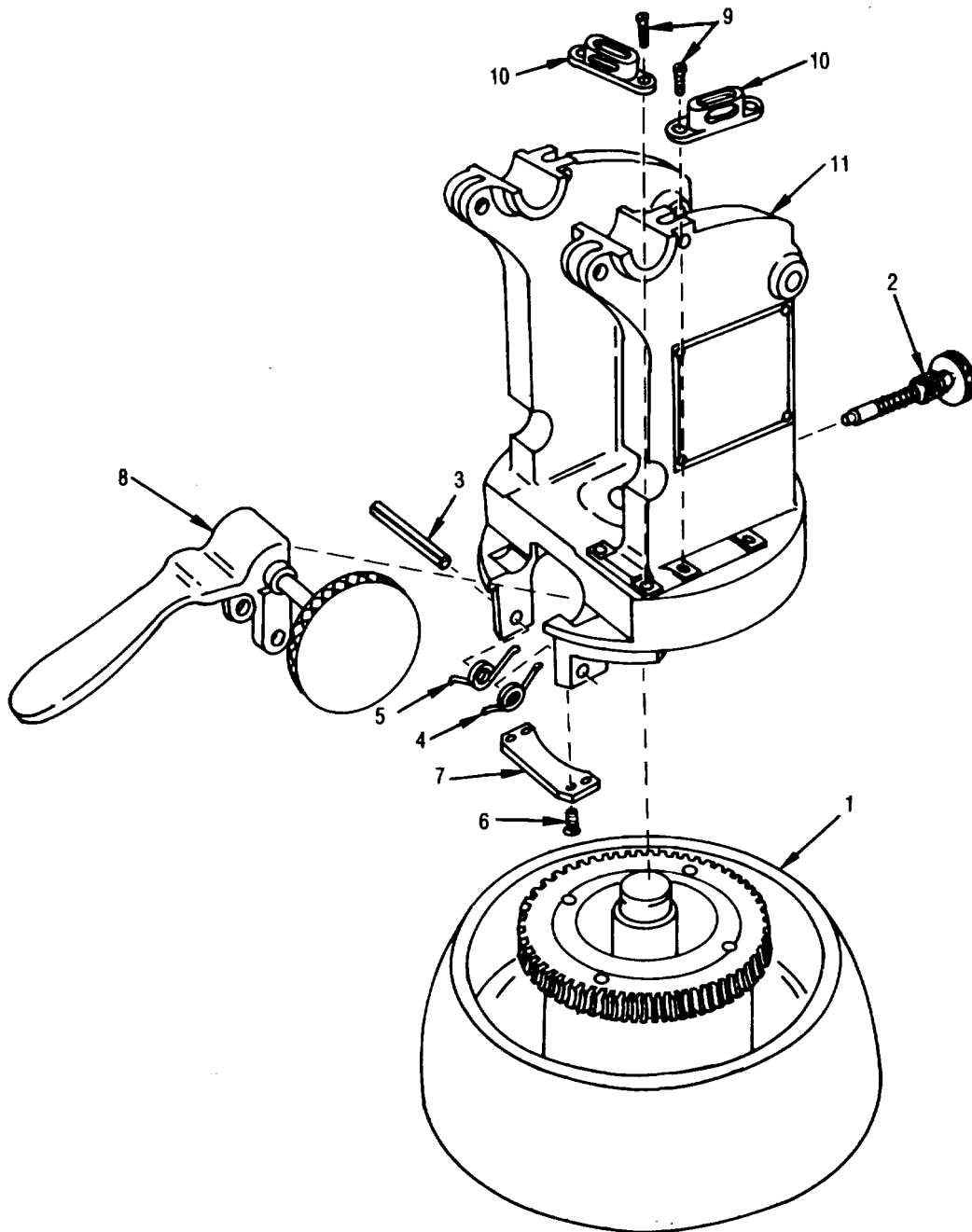

AR 902731

Legend

- | | |
|-----------------------------------|--------------------------------|
| 1. Fixed Base Assembly - 11578756 | 7. Plate - 11578644 |
| 2. Locking Assembly - 11578757 | 8. Lever Assembly - 11578755 |
| 3. Spring Pin - 11578615 | 9. Level Vial Screw - 11578679 |
| 4. Right Spring - 11578642 | 10. Level Vial - 11578654 |
| 5. Left Spring - 11578641 | 11. Upper Mount- 11578620 |
| 6. Plate Screw - 11578662 | |

Figure 6-4. Disassembly/assembly of mount group

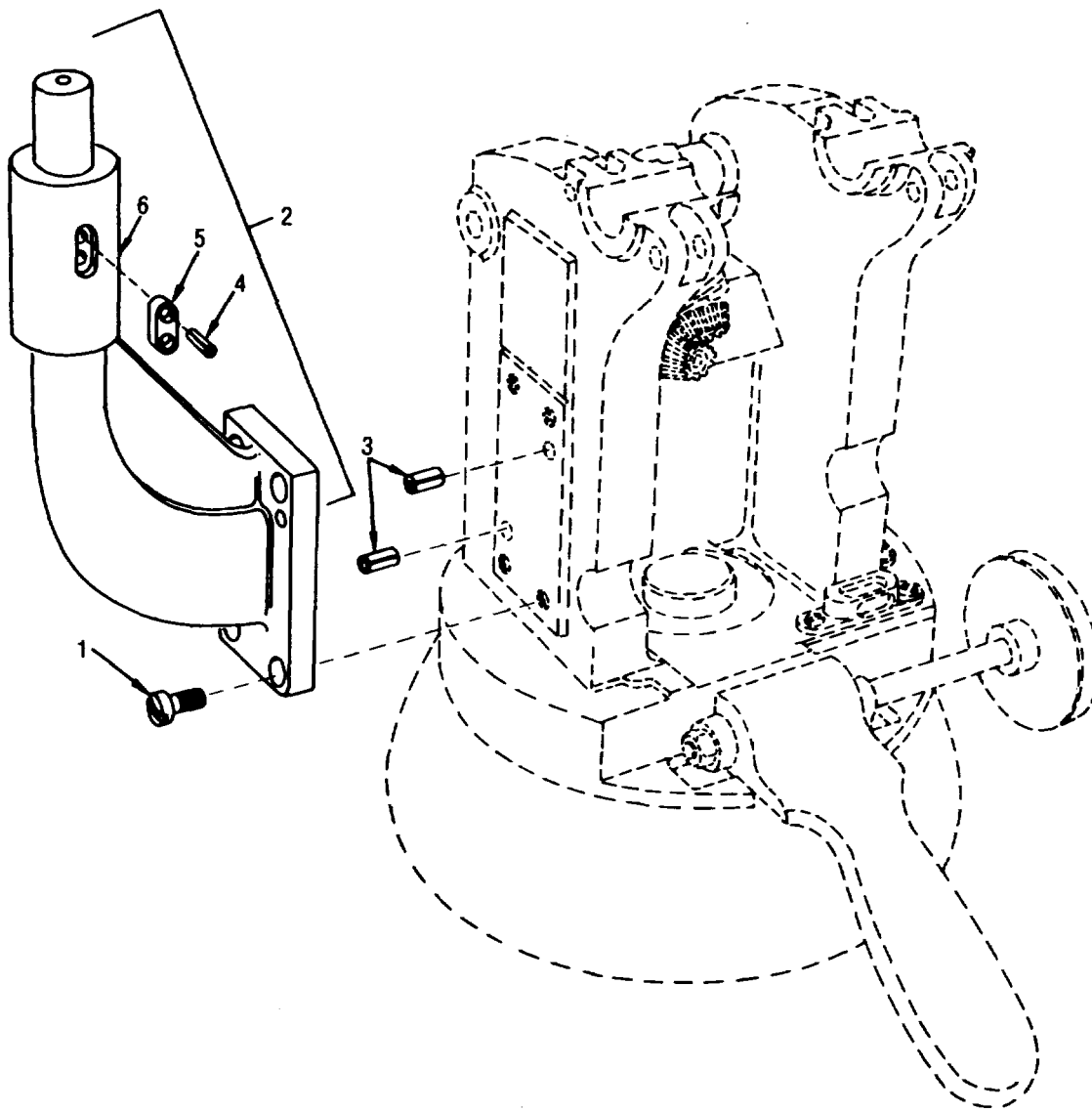

DRILL EXISTING HOLES TO $0.196 + 0.002$ DIAMETER AND $0.63 + 0.02$ DEEP TO ACCEPT SPRING PIN (3)
 DRILL EXISTING HOLES TO $0.118 + 0.004$ DIAMETER AND $0.41 + 0.01$ DEEP TO ACCEPT SPRING PINS (4)

AR 902759

Legend

- | | |
|------------------------------------------|----------------------------------------|
| 1. Telescope Bracket Screw - 11578746 | 4. Spring Pin - 11578715 |
| 2. Telescope Bracket Assembly - 11578714 | 5. Bracket Key - 11578716 |
| 3. Spring Pin - 11578747 | 6. Telescope Socket Bracket - 11578659 |

Figure 6-5. Replacing telescope bracket assembly

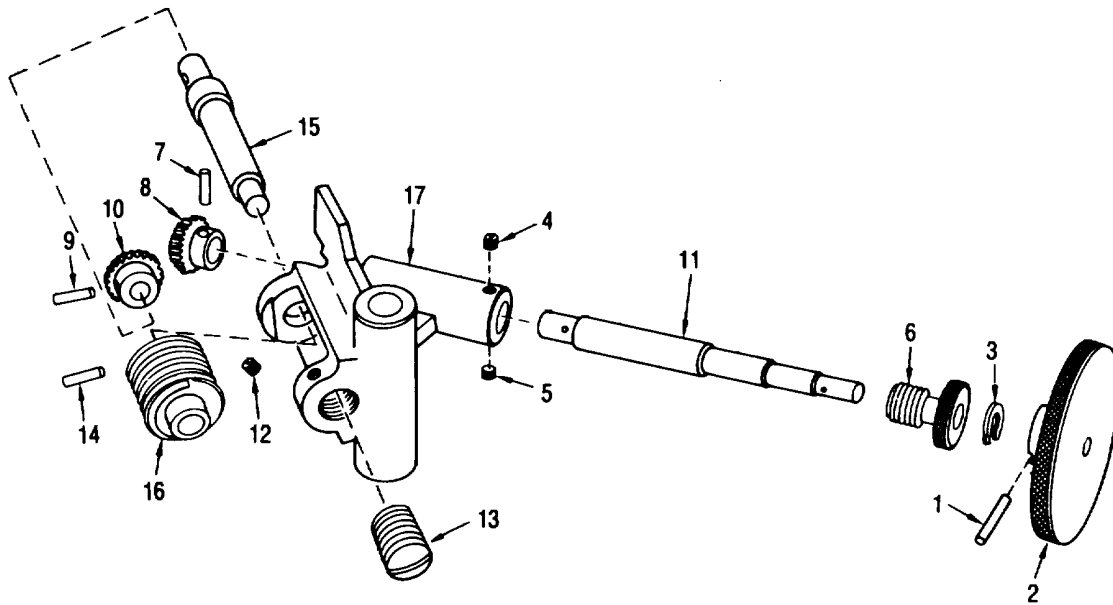

PRESS GEARS AND HANDWHEEL TIGHT AGAINST SHOULDER AND DRILL 0.078 + 0.004 HOLE TO ACCEPT SPRING PINS (1, 7, 9, AND 14)
 ADJUST SCREW (13) FOR 0.002 MAXIMUM WORM GEAR END PLAY BEFORE TIGHTENING SETSCREW (12).
 ADJUST BUSHING (6) FOR 0.002 MAXIMUM HANDWHEEL BACKLASH BEFORE TIGHTENING SETSCREW.

AR 902763

Legend

- | | |
|--------------------------|--------------------------------------------|
| 1. Spring Pin - 11578680 | 10. Bevel Gear - 11578650 |
| 2. Handwheel - 11578651 | 11. Shaft - 11578652 |
| 3. Snap Ring - 11578673 | 12. Setscrew - 11578672 |
| 4. Setscrew - 11578672 | 13. Adjusting Screw - 11578657 |
| 5. Setscrew - 11578672 | 14. Spring Pin - 11578680 |
| 6. Bushing - 11578658 | 15. Shaft - 11578653 |
| 7. Spring Pin - 11578680 | 16. Worm Gear - 11578656 |
| 8. Bevel Gear - 11578650 | 17. Elevating Worm Gear Bracket - 11578709 |
| 9. Spring Pin - 11578680 | |

Figure 6-6. Disassembly/assembly of elevating worm gear assembly

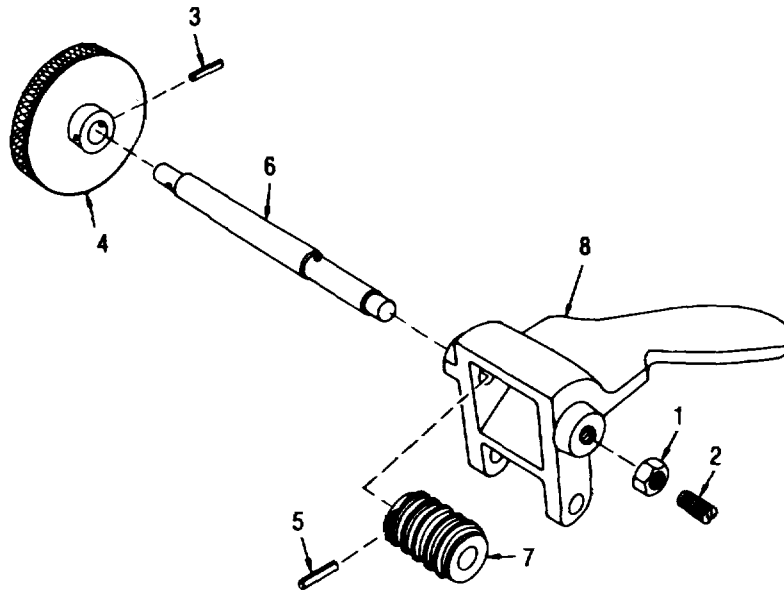

PRESS WORM GEAR AND HANDWHEEL TIGHT AGAINST SHOULDER AND DRILL 0.078 + 0.004 TO ACCEPT SPRING PINS (3 AND 5)
 ADJUST SETSCREW (2) FOR 0.002 MAXIMUM WORM GEAR END PLAY AND THEN TIGHTEN NUT (1)

AR 902764

Legend

- | | |
|------------------------------------|--------------------------------|
| 1. Shaft Nut - 11578664 | 5. Spring Pin - 11578680 |
| 2. Shaft Setscrew - 11578665 | 6. Traversing Shaft - 11578639 |
| 3. Spring Pin - 11578680 | 7. Worm Gear- 11578635 |
| 4. Traversing Handwheel - 11578651 | 8. Traverse Lever - 11578661 |

Figure 6-7. Disassembly/assembly of rapid traverse lever assembly

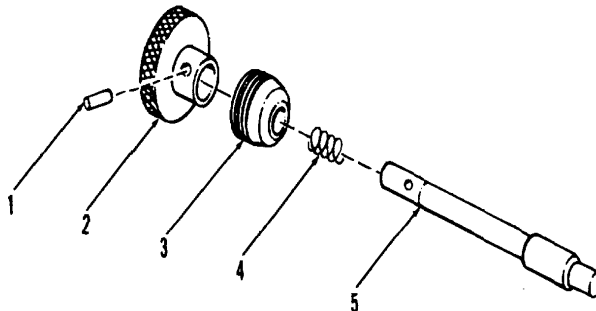

DRILL HOLE FOR SPRING PIN (1) IN REPLACEMENT KNOB (2) OR PLUNGER (5) AS FOLLOWS:

1. PLACE KNOB ON PLUNGER
2. CHECK THAT END OF PLUNGER IS FLUSH WITH OUTER SIDE OF KNOB WITHIN 0.01
3. DRILL 0.078 + 0.004 HOLE THROUGH KNOB AND PLUNGER

AR 902765

Legend

- | | |
|-------------------------------|-------------------------------|
| 1. Spring Pin - 11578680 | 4. Spring - 11578660 |
| 2. Locking Knob - 11578618 | 5. Locking Plunger - 11578619 |
| 3. Locking Bushing - 11578637 | |

Figure 6-8. Disassembly/assembly of plunger locking assembly

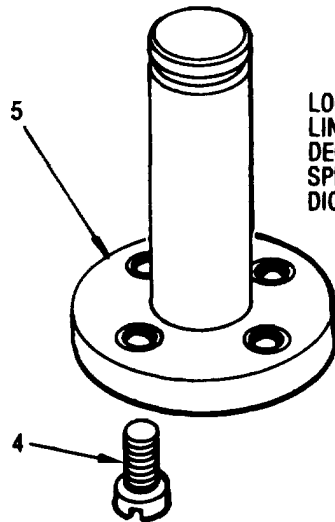
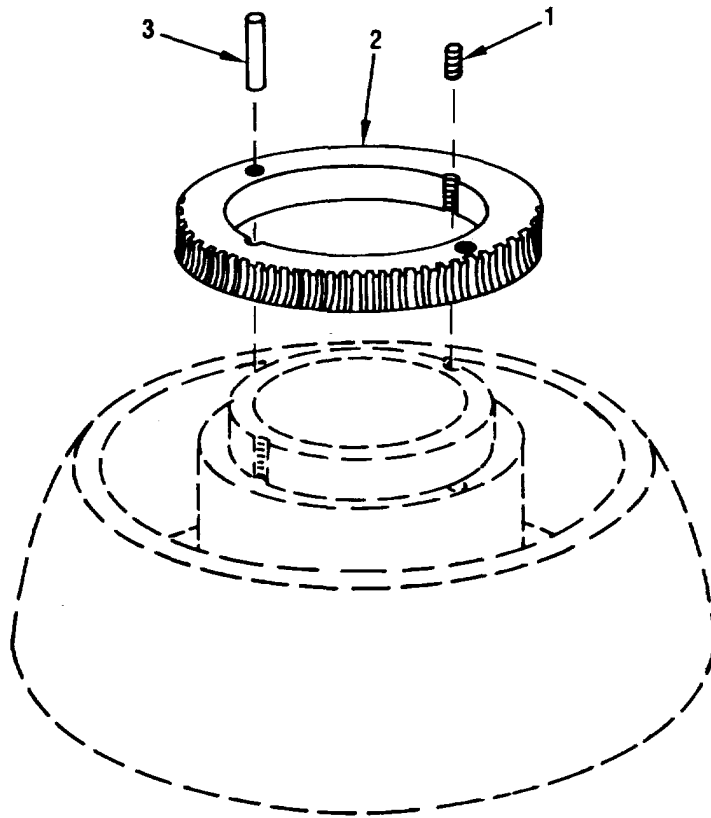

LOCATE, DRILL AND TAP HOLES FOR SETSCREW (1) AT PART LINE, 180 DEGREES APART IN REPLACEMENT GEAR (2) 45 DEGREES FROM ORIGINAL POSITION. DRILL HOLES FOR SPRING PIN (3) ON CENTER LINE OF GEAR (2) AND PERPENDICULAR TO SETSCREW (1).

AR 902762

Legend

- | | |
|-------------------------------|--------------------------------|
| 1. Setscrew - 11578667 | 4. Pintle Pin Screw - 11578666 |
| 2. Worm Wheel Gear - 11578643 | 5. Pintle Pin - 11578621 |
| 3. Spring Pin - 11578668 | |

Figure 6-9. Disassembly/assembly of fixed mount base assembly

Section IV. MAINTENANCE OF THE TRIPOD MOUNT ASSEMBLY

6-18. Disassembly. Disassemble the tripod mount assembly as shown in figures 6-10 through 6-13.

6-19. Cleaning, Inspection, and Repair.

- a. *Cleaning.* Refer to paragraph 6-8.
- b. *Inspection.* Refer to paragraphs 5-4 and 5-5.

c. *Repair.* Refer to paragraph 6-3.

6-20. Assembly. Assemble the tripod mount assembly as shown in figures 6-10 through 6-13.

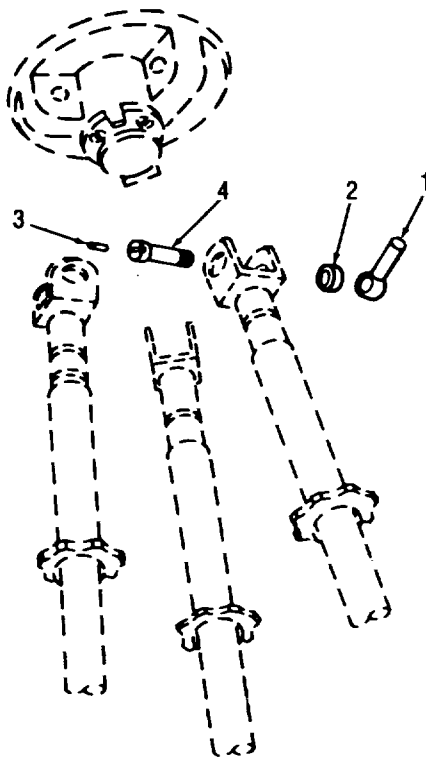

TIGHTEN REPLACEMENT SCREW (4) FINGER TIGHT WITH LEVER (1) IN THE 3 O'CLOCK POSITION, THEN DRILL AND TAP HOLE FOR SETSCREW (3).

AR 902766

Legend

- 1. Locking Lever - 11578691
- 2. Spacer- 11578681
- 3. Setscrew - 11578667
- 4. Locking Screw - 11578693

Figure 6-10. Replacement of tripod locking lever group

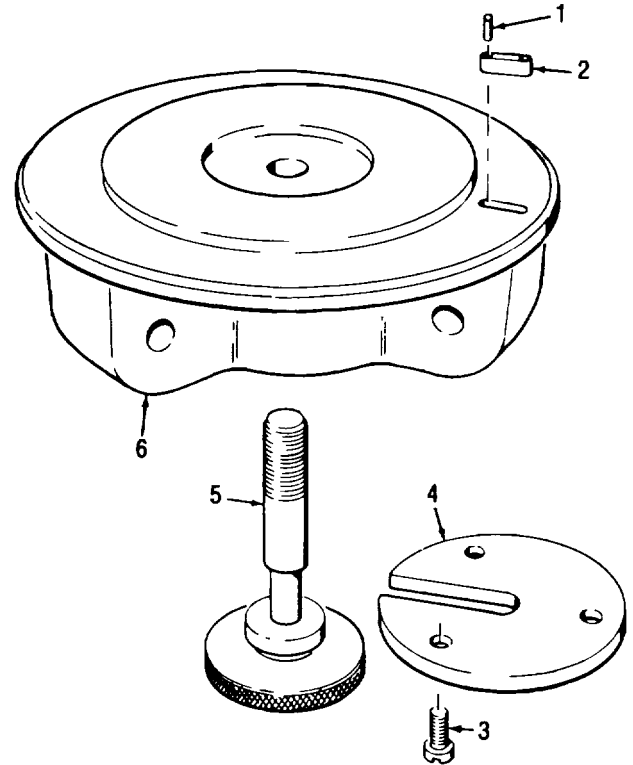

DRILL 0.118 + 0.004 DIAMETER HOLES FOR SPRING PINS (1) IN REPLACEMENT KEY (2). PINS MUST BE FLUSH WITH TOP OF KEY.

AR 902767

Legend

- 1. Spring Pin - 11578715
- 2. Key- 11578716
- 3. Retainer Screw - 11578717
- 4. Retainer - 11578683
- 5. Locking Screw - 11578682
- 6. Tripod Base - 11578689

Figure 6-11. Disassembly/assembly of tripod base assembly

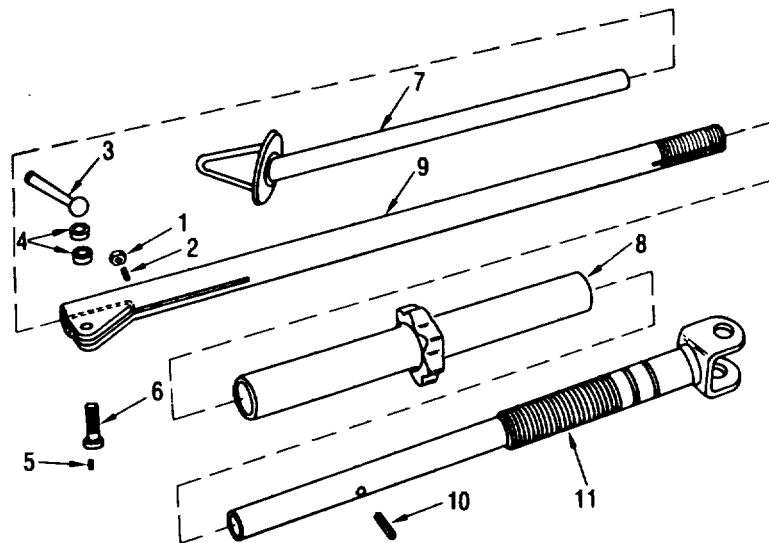

DRILL AND TAP HOLE FOR SETSCREW (5) IN SCREW (6) AT ASSEMBLY.

AR 902768

Legend

- | | |
|-------------------------------|--------------------------------|
| 1. Guide Screw Nut - 11578712 | 7. Rear Leg - 11578684 |
| 2. Guide Screw - 11578711 | 8. Adjusting Sleeve - 11578692 |
| 3. Locking Lever - 11578691 | 9. Lower Rear Leg - 11578690 |
| 4. Lever Spacer- 11578681 | 10. Pin- 11578710 |
| 5. Setscrew - 11578667 | 11. Upper Leg - 11578688 |
| 6. Bolt - 11578694 | |

Figure 6-12. Disassembly/assembly of tripod rear leg assembly

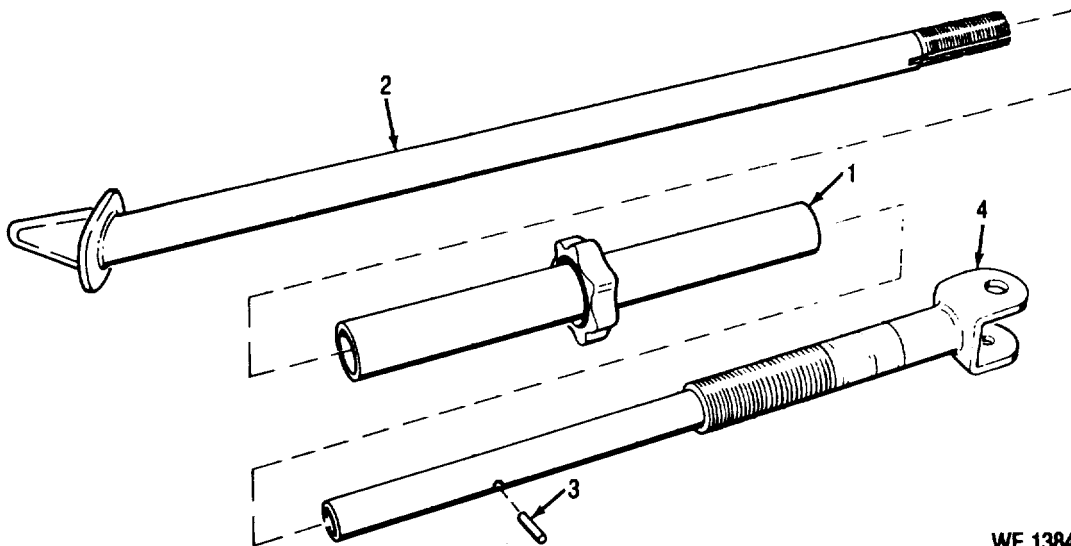

WE 13849

Legend

- | | |
|--------------------------------|-------------------------|
| 1. Adjusting Sleeve - 11578692 | 3. Pin - 11578710 |
| 2. Lower Front Leg - 11578685 | 4. Upper Leg - 11578688 |

Figure 6-13. Disassembly/assembly of tripod front leg group

Section V. MAINTENANCE OF THE TELESCOPE SOCKET, HOLDER, AND SUPPORT ASSEMBLIES

6-21. Disassembly. Disassemble telescope socket, holder, and support assemblies in accordance with figures 6-14 through 6-16.

6-22. Cleaning, Inspection, and Repair.

- a. *Cleaning.* Refer to paragraph 6-8.
- b. *Inspection.* Refer to paragraphs 5-4 and 5-5.

c. *Repair.* Refer to paragraph 6-3.

6-23. Assembly. Assemble telescope socket, holder, and support assemblies in accordance with figures 6-14 through 6-16.

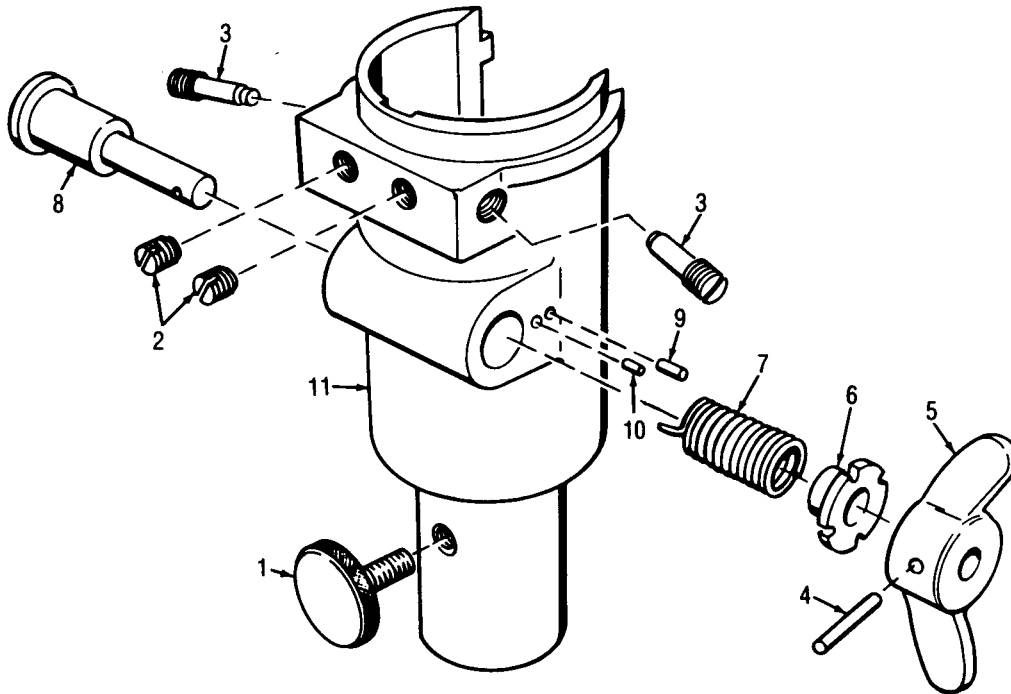

ASSEMBLE SPRING (7) AND RETAINER (6) FOR A MINIMUM OF 2 IN-LB TORQUE WITH THE WINGS OF HANDLE (5) TURNED 45 DEGREES FROM VERTICAL

Legend

- | | |
|-------------------------------|---------------------------------|
| 1. Locking Screw - 11578705 | 7. Lock Spring - 11578703 |
| 2. Setscrew- 11578704 | 8. Telescope Lock - 11578697 |
| 3. Tangent Screw - 11578698 | 9. Spring Pin - 11578706 |
| 4. Spring Pin - 11578708 | 10. Spring Pin - 11578707 |
| 5. Lock Handle - 11578702 | 11. Telescope Socket - 11578699 |
| 6. Spring Retainer - 11578701 | |

Figure 6-14. Disassembly/assembly of telescope socket assembly

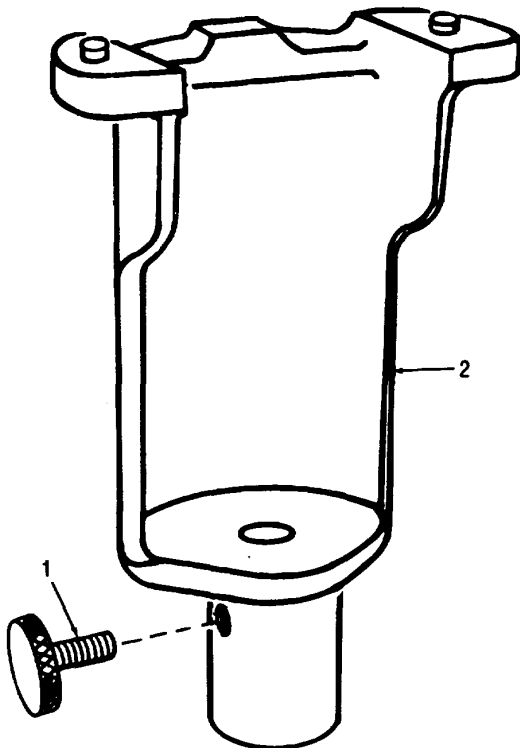

AR 902738

- Legend
 1. Screw - 11727518
 2. Holder- 11727519

Figure 6-15. Disassembly/assembly of telescope holder assembly

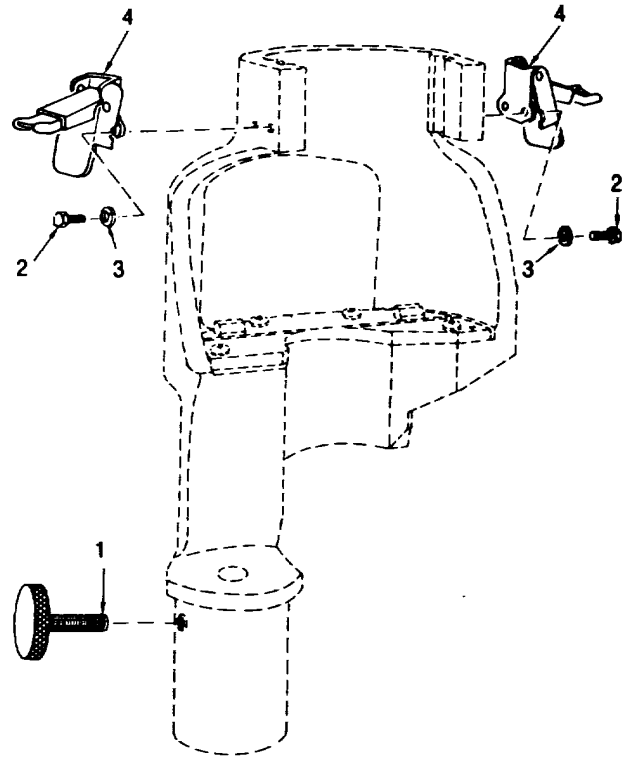

AR 902742

- Legend
 1. Screw- 11727518
 2. Screw
 3. Washer
 4. Catch- 10531763

Figure 6-16. Disassembly/assembly of telescope support assembly - exploded view

Section VI. FINAL INSPECTION

6-24. General. Final inspection is performed after repair has been completed to insure that materiel is acceptable for return to user or for return to replacement stock according to the standards established.

6-25. Final Inspection. Refer to table 6-1 for final inspections.

Table 6-1. Final Inspection

Component or assembly	Point or item of inspection	Method of inspection	Acceptable condition
Barrel assembly	Overall	Visual	All parts must be present and secure. Test for proper functioning.
	Breech bolt, safety, trigger, and bolt lock plunger	Manual	
Mount assembly	Overall	Visual	Inspect for appearance. All painted surfaces must be covered; all parts must be present and securely fastened; and identification plate must be secure and legible.
	Elevating group	Manual	Elevate and depress trainer several times Operation must be smooth and free.
	Traversing group	Manual	Traverse trainer several times Operation must be smooth and free.
	Mount locking plunger	Manual	Must lock upper (rotating) mount to fixed base mount.
	Rapid traverse lever	Manual	Must release worm gear from worm wheel gear for rapid traverse.
Tripod mount assembly	Overall	Visual	Inspect for appearance. All painted surfaces must be covered, and all parts must be present and securely fastened.
	Trunnion caps	Manual	Must hold barrel assembly securely on mount assembly.
	Mount locking screw	Manual	Must hold mount assembly securely on tripod base.
	Leg locking levers	Manual	Must hold tripod legs securely in position.
Telescope socket, holder, and support assemblies	Overall	Visual	Inspect for appearance. All painted surfaces must be covered, and all parts must be present and securely fastened.
Adapter assembly	Telescope lock	Manual	Must secure telescope.
	Caps	Manual	Must hold barrel assembly securely in adapter.
	Jib	Manual	Must hold adapter securely in major caliber gun.
	Locking bar	Manual	Must hold adapter securely in major caliber gun.
	Locking nut	Manual	Must hold adapter securely in major caliber gun.
	Adjusting screws	Manual	Must adjust, and hold subcaliber gun in boresighted position.

CHAPTER 7 AMMUNITION

7-1. General. The 14.5-mm trainer ammunition is classified as 'fixed' ammunition and is ready for firing as it comes from the packing box. The cartridge size and manufacturer's identification are stamped on the base of the cartridge case. Subparagraph 1-4f shows an example of cartridge markings. Projectiles with two types of fuze action are available for use with the trainer:

(1) A point-detonating (PD) fuze (M183) which functions on impact.

(2) A 3-second delay fuze (M181) and a 6-second delay fuze (M182) which present airbursts when fired at a time of flight in excess of 3 seconds and 6 seconds respectively from the time of firing. The latter two fuzes are not "delay" as we think of them. They are factory set time fuzes which do not have a point-detonating element. A cross section of the 14.5-mm projectile is shown in subparagraph 1-4f. The projectile is coated with cosmoline under the cartridge case.

7-2. Ammunition Type. Ammunition for the 14.5-mm field artillery trainer M31 is classified as "fixed" ammunition type. A cartridge (complete round of ammunition) consists of all the ammunition components necessary to fire the trainer once; this includes a loaded projectile, a propelling charge, a primer, and a fuze. A cross section of a cartridge is shown in subparagraph 1-4f.

7-3. Cartridges. There are three kinds of cartridges available for use with the trainer, as indicated below.

a. Cartridge M183 (subparagraph 1-4f) has a point detonation (PD) fuze that produces smoke with a slight detonation upon impact. The smoke cloud produced is visible with the naked eye at a distance up to 3,280 feet (1000 m) by day, and is visible by a flash at night.

b. Cartridge M181 has a fuze which has a three second delay detonation action. The other characteristics are the same as M183 above.

c. Cartridge M 182 has a fuze which has a six second delay detonation action. The other characteristics are the same as M183 above.

7-4. Ballistic Data. This ammunition is capable of functioning with all the ballistic properties of an artillery combat projectile. Propelling charge is 0.22g (3.5 gr), producing 328 f/s (100 m/s) initial velocity. Maximum effective range is 798.3 yds (730 m).

7-5. Markings. Fuze designation, charge designation, and manufacturer's lot number are inscribed on the side of the cartridge case with a black indelible ink (subparagraph 1-4f).

7-6. Packaging. Ten cartridges are packed in a cardboard box. Each box is marked with quantity of cartridges, charge designation, fuze designation, model number, and lot number.

7-7. Preparation for Firing.

a. The cartridges are ready for firing as they come from the cardboard box.

b. Some of the cosmoline may appear on the projectile forward of the cartridge case. Unless the exposed cosmoline collects dust or dirt, it should not be removed. The cartridge should be free of all foreign matter before loading. In order to keep the ammunition clean, the round should not be removed from the cardboard box until immediately before firing.

c. The ammunition should be protected from the sun, rain, dust, or other damaging elements in order to maintain standard performance. Due to the low muzzle velocity (100 meters per second) a small increase or decrease from standard will result in several decimeters in range dispersion.

7-8. Dud Policing and Disposal. After firing on other than a permanent range, police the surface area to locate dud projectiles. Dud projectiles will be conspicuously marked for later identification. Flags, engineer tape, etc., may be used. Personnel will not attempt to pick up duds with their hands or disturb the duds during policing. The retrieving of duds to permit disposal by burning or demolition is authorized only when the equipment used to retrieve the dud provides adequate protection to

retrieving personnel. If M181 and M182 projectiles have been fired, the retrieving equipment must protect personnel against fragmenting in case fuze functioning occurs during retrieval. Long handle tongs (24-inch) may be used only to retrieve dud projectiles from the M183 cartridge. When picking up a dud with the tongs, position the projectile in the tongs so that the plastic cap is away from the body. Dud projectiles will be carried at

the side of the body, parallel to the ground and with the fuze end forward. Dud projectiles will be disposed of by blowing the projectile in place utilizing standard demolition methods or by collecting the duds and burning in an open pit. When using the open pit burning method, sufficient combustible material should be used to assure complete burning.

CHAPTER 8

SHIPMENT AND LIMITED STORAGE

8-1. Shipping.

a. *Responsibility.* When shipping the trainer or subcaliber device, the officer in charge of preparing the shipment will be responsible for furnishing the materiel in a serviceable condition and properly processed for shipment, including the preparation of Army shipping documents.

b. *Army Shipping Documents.* Prepare all Army shipping documents in accordance with AR 725-50.

c. *Preparation for Shipment.* Materiel removed from storage for shipment need not be reprocessed unless inspection reveals it is inadequately preserved.

8-2. Cleaning and Drying.

a. *Cleaning.* Remove dirt and other foreign matter

from surfaces of the trainer or subcaliber device with clean, lint-free, dry cloths.

b. *Drying.* Components must be thoroughly dried before preservation and packaging.

8-3. Preservation and Packaging. Specific preservation and packaging instructions are not available for the trainer or subcaliber device at this time. However, procedures similar to those outlined for machine guns in TB ORD 623 and TM 38-230 will be followed for the trainer.

8-4. Marking. Marking will be in accordance with TM 38-230.

8-1 (8-2 blank)

**APPENDIX A
REFERENCES**

A-1. Table of Allowances The following Department of the Army table of allowances pertains to this materiel:

Ammunition, Rockets, and Missiles for Training TA 23-100

A-2. Technical Manuals The following Department of the Army technical manuals pertain to this materiel:

Ammunition and explosives standards..... TM 9-1300-206
 Ammunition maintenance TM 9-1300-250
 Materiel Used for Cleaning, Preserving, Abrading and Cementing Ordnance
 Materiel; and Related Materiel Including Chemicals TM 9-247
 Operation and Maintenance of Ordnance Materiel in Cold Weather (0° to -65°F)..... TM 9-207
 Operator's Manual: Welding Theory and Application TM 9-237
 Painting Instructions for Field Use..... TM 43-0139
 Preservation, Packaging, and Packing of Military Supplies and Equipment,
 Preservation and Packaging (volume 1) TM 38-230-1
 The Army Maintenance Management System (TAMMS)..... DA PAM 738-750

Change 2 A-1/(A-2 Blank)

APPENDIX B MAINTENANCE ALLOCATION CHART

Section I. INTRODUCTION

B-1. General.

a. This section provides a general explanation of all maintenance and repair functions authorized at various maintenance levels.

b. The Maintenance Allocation Chart (MAC) in section II designates overall responsibility for the performance of maintenance functions on the identified end item or component. The implementation of the maintenance functions upon the end item or component will be consistent with the assigned maintenance functions.

c. Section III lists the special tools and test equipment required for each maintenance function as referenced from section II.

d. Section IV contains supplemental instructions on explanatory notes for a particular maintenance function.

B-2. Maintenance Functions.

a. *Inspect.* To determine the serviceability of an item by comparing its physical, mechanical and/or electrical characteristics with established standards through examination.

b. *Test.* To verify serviceability and detect incipient failure by measuring the mechanical or electrical characteristics of an item and comparing those characteristics with prescribed standards.

c. *Service.* Operations required periodically to keep an item in proper operating condition, i.e., to clean (decontaminate), to preserve, to drain, to paint, or to replenish fuel, lubricants, hydraulic fluids, or compressed air supplies.

d. *Adjust.* To maintain, within prescribed limits, by bringing into proper or exact position, or by setting the operating characteristics to specified parameters.

e. *Align.* To adjust specified variable elements of an item to bring about optimum or desired performance.

f. *Calibrate.* To determine and cause corrections to be made or to be adjusted on instruments or test measuring and diagnostic equipments used in precision measurement. Consists of comparisons of two instruments, one of which is a certified standard of known accuracy, to detect and adjust any discrepancy in the accuracy of the instrument being compared.

g. *Install.* The act of emplacing, seating, or fixing into position an item, part, or module (component or assembly) in a manner to allow the proper functioning of an equipment or system.

h. *Replace.* The act of substituting a serviceable like type part, subassembly, or module (component or assembly) for an unserviceable counterpart.

i. *Repair.* The application of maintenance services¹ or other maintenance actions² to restore serviceability to an item by correcting specific damage, fault, malfunction, or failure in a part, subassembly, module (component or assembly), end item, or system.

j. *Overhaul.* That maintenance effort (services/actions) necessary to restore an item to a completely serviceable/operational condition as prescribed by maintenance standards (i.e., DMWR) in appropriate technical publications. Overhaul is normally the highest degree of maintenance performed by the Army. Overhaul does not normally return an item to like new condition.

k. *Rebuild.* Consists of those services/ actions necessary for the restoration of unserviceable equipment to a like new condition in accordance with original manufacturing standards. Rebuild is the highest degree of materiel maintenance applied to Army equipment. The rebuild operation includes the act of returning to zero those age measurements (hours/miles, etc.) considered in classifying Army equipments/ components.

¹Services - inspect, test, service, adjust, align, calibrate, or replace.

²Action - welding, grinding, riveting, straightening, facing, remachining, or resurfacing.

B-3. Column Entries Used in the MAC.

a. *Column 1, Group Number.* Column 1 lists group numbers, the purpose of which is to identify components, assemblies, subassemblies, and modules with the next higher assembly.

b. *Column 2, Component/Assembly.* Column 2 contains the names of components, assemblies, subassemblies, and modules for which maintenance is authorized.

c. *Column 3, Maintenance Functions.* Column 3 lists the functions to be performed on the item listed in column 2. (For detailed explanation of these functions, see para. B-2)

d. *Column 4, Maintenance Level.* Column 4 specifies, by the listing of a "work time" figure in the appropriate subcolumn(s), the lowest level of maintenance authorized to perform the function listed in column 3. This figure represents the active time required to perform the maintenance function at the indicated level of maintenance. If the number or complexity of the tasks within the listed maintenance function vary at different maintenance levels, appropriate "work time" figures will be shown for each level. The number of manhours specified by the "work time" figure represents the average time required to restore an item (assembly, subassembly, component, module, end item, or system) to a serviceable condition under typical field operating conditions. This time includes preparation time, troubleshooting time, and quality assurance/quality control time in addition to the time required to perform the specific tasks identified for the maintenance functions authorized in the maintenance allocation chart. The symbol designations for the various maintenance levels are as follows:

- C..... Operator or crew.
- O..... Organization maintenance.
- F..... Direct support maintenance.
- H..... General support maintenance.
- D..... Depot maintenance.

e. *Column 5, Tools and Equipment.* Column 5 specifies, by code, those common tool sets (not individual tools) and special tools, test, and support equipment required to perform the designated function.

f. *Column 6, Remarks.* This column shall contain a letter code in alphabetic order which shall be keyed to the remarks contained in Section IV.

B-4. Column Entries Used in Tool and Test Equipment Requirements.

a. *Column 1, Tool or Test Equipment Reference Code.* The tool and test equipment reference code correlates with a maintenance function on the identified end item or component.

b. *Column 2, Maintenance Level.* The lowest level of maintenance authorized to use the tool or test equipment.

c. *Column 3, Nomenclature.* Name or identification of the tool or test equipment.

d. *Column 4, National/NATO Stock Number.* The National or NATO stock number of the tool or test equipment.

e. *Column 5, Tool Number.* The manufacturer's part number.

B-5. Explanation of Columns in Section IV.

a. *Reference Code.* The code scheme recorded in column 6, section II.

b. *Remarks.* This column lists information pertinent to the maintenance function being performed as indicated on the MAC, section II.

Section II. MAINTENANCE ALLOCATION CHART

(1) Group number	(2) Component/Assembly	(3) Maint. function	(4) Maint. level					(5) Tools and equipment	(6) Remarks
			C	O	F	H	D		
01.	BARREL ASSEMBLY	Inspect	0.1						
		Service	0.2						
		Install	0.1						
		Repair			1.5				
		Overhaul					2.0		
01.01	Barrel Trunnion and Receiver Assembly	Inspect		0.2					
		Service	0.1						
		Replace					0.5		
		Repair					1.0		
		Overhaul					1.5		
01.02	Breech Bolt Group	Inspect	0.1					1	
		Service	0.1						
		Replace			0.1				
		Repair		0.3					
		Overhaul					0.8		
01.03	Artillery Trainer Safety	Inspect	0.1						
		Service	0.1						
		Replace			0.2				
		Repair			0.5				
		Overhaul					1.0		
01.04	Trainer Trigger	Inspect	0.1						
		Service	0.1						
		Replace		0.2					
		Repair			0.3				
		Overhaul					0.8		
02.	MOUNT ASSEMBLY	Inspect	0.1						
		Service	0.2						
		Install	0.1						
		Repair			2.1				
		Overhaul					2.6		
02.01	Elevating Mechanism Group	Inspect		0.1					
		Service	0.1						
		Adjust		0.1					
		Replace			0.2				
		Repair			1.0				
		Overhaul					1.5		
02.02	Traversing Mechanism Group	Inspect		0.1					
		Service		0.1					
		Adjust		0.1					
		Replace			0.2				
		Repair			1.0				
		Overhaul					1.5		
02.03	Rapid Traversing Group	Inspect		0.1					
		Service		0.1					
		Replace			0.3				
		Repair			0.5				
		Overhaul					1.0		
		B-3							

Section II. MAINTENANCE ALLOCATION CHART - Continued

(1) Group number	(2) Component/Assembly	(3) Maint. function	(4) Maint. level					(5) Tool/ equipment	(6) Remarks
			C	O	F	H	D		
02.04	Trunnion Caps	Inspect Service Replace Repair Overhaul	0.1 0.1		1.0 1.0		1.5		
02.05	Base Group	Inspect Service Replace Repair Overhaul	0.2 0.1		0.5 2.0		2.5		
02.06	Elevating Bracket Plunger Group	Inspect Service Replace Repair Overhaul	0.1 0.1		0.3 1.5		2.0		
02.07	Mount Locking Plunger Group	Inspect Service Replace Repair Overhaul	0.1 0.1		0.3 1.5		2.0		
02.08	Artillery Trainer Level Vials	Inspect Service Replace Repair Overhaul	0.1 0.1		0.2 1.0		1.5		
02.09	Telescope Socket Bracket Group	Inspect Service Replace Repair Overhaul	0.1 0.1		1.0 1.0		1.5		
03.	TRIPOD MOUNT ASSEMBLY	Inspect Service Install Repair Overhaul	0.2 0.2 0.1		3.0		3.5		
03.01	Tripod Base Group	Inspect Service Replace Repair Overhaul	0.1 0.1		1.0 1.5		2.0		
03.02	Leg Assemblies	Inspect Service Replace Repair Overhaul	0.1 0.2		0.5 1.5		2.0		
		B4							

Section II. MAINTENANCE ALLOCATION CHART - Continued

(1) Group number	(2) Component/Assembly	(3) Maint. function	(4) Maint. level					(5) Tools and equipment	(6) Remarks
			C	O	F	H	D		
			04	TELESCOPE SUPPORT ASSEMBLIES	Inspect Service Install Replace Repair Overhaul	0.1 0.2 0.2			
05.	ADAPTER ASSEMBLIES	Inspect Service Install Replace Repair Overhaul	0.1 0.2 0.3		0.2 0.3		0.8		
06.	LANYARD HOLDER ASSEMBLIES	Inspect Service Install Replace Repair Overhaul	0.1 0.1 0.2	0.5	0.2		1.0		

Section III. TOOL AND TEST EQUIPMENT REQUIREMENTS

REF. CODE	MAINT. LEVEL	NOMENCLATURE	NATIONAL/NATO STOCK NUMBER	TOOL* NUMBER
1	F	Gage, Field Headspace Note No special test equipment is required for basic weapon. AU other necessary tools are contained in Tool Kit, Small Arms Repairman (SC 4933-95-CL-A07), NSN 493340-357-7770, LIN Item W510910.	692010-025-4596	11578863

Section IV. REMARKS

Reference Code	Remarks
	None applicable

APPENDIX C
BASIC ISSUE ITEMS LIST AND ITEMS TROOP INSTALLED OR AUTHORIZED LIST AND ORGANIZATIONAL AND DIRECT SUPPORT MAINTENANCE REPAIR PARTS AND SPECIAL TOOLS LIST

Section I. - INTRODUCTION

C-1. **Scope.** This manual lists basic issue items; items troop installed or authorized; repair parts; special tools; test, measurement, and diagnostic equipment (TMDE); and other support equipment required for operation and performance of organizational and direct support maintenance of the 14.5-mm trainer M31.

C-2. **General.** This Basic Issue Items, Items Troop Installed or Authorized, Repair Parts and Special Tools List is divided into into the following sections:

a. *Section II. Basic Issue Items List.* A list of items which are furnished with and which must be turned in with the end item.

b. *Section III. Items Troop Installed or Authorized List.* A list of items which, at the discretion of the unit commander, may accompany the end item, but should not be turned in with the end item.

c. *Section IV. Repair Parts List.* A list of repair parts authorized for use in the performance of maintenance. The list also includes parts which must be removed for replacement of the authorized parts. Parts lists are composed of functional groups in ascending numerical sequence, with the parts in each group listed in figure and item number sequence. Bulk materials are listed in NSN sequence.

d. *Section V. Special Tools List.* A list of special tools, TMDE, and support equipment authorized for the performance of maintenance at the organizational level.

e. *Section VI. National Stock Number and Part Number Index.* A list, in ascending numerical sequence, of all National stock numbers appearing in the listings, followed by a list, in alphameric sequence, of all part numbers appearing in the listing. National stock number

and part numbers are cross-referenced to each illustration figure and item number appearance. This index is followed by a cross-reference list of reference designations to figure and item numbers when applicable.

C-3. **Explanation of Columns..** The following provides an explanation of columns found in the tabular listings:

a. *Illustration.* This column is divided as follows:

(1) *Figure Number.* Indicates the figure number of the illustration in which the item is shown.

(2) *Item Number.* The number used to identify each item called out in the illustration.

b. *Source, Maintenance, and Recoverability Codes (SMR).*

(1) *Source Code.* Source codes are assigned to support items to indicate the manner of acquiring support items for maintenance, repair, or overhaul of end items. Source codes are entered in the first and second positions of the Uniform SMR Code format as follows:

Code	Definition
PA	-Item procured and stocked for anticipated or known usage.
PB	- Item procured and stocked for insurance purpose because essentiality dictates that a minimum quantity be available in the supply systems.

- PC - Item procured and stocked and which otherwise would be coded PA except that it is deteriorative in nature.
- PD - Support item, excluding support equipment, procured for initial issue or outfitting and stocked only for subsequent or additional initial issues or outfittings. Not subject to automatic replenishment.
- PE - Support equipment procured and stocked for initial issue or outfitting to specified maintenance repair activities.
- PF - Support equipment which will not be stocked but which will be centrally procured on demand.
- PG - Item procured and stocked to provide for sustained support for the life of the equipment. It is applied to an item peculiar to the equipment which, because of probable discontinuance or shutdown of production facilities, would prove uneconomical to reproduce at a later time.
- KF - An item of a maintenance kit and not purchased separately. Maintenance kit defined as a kit that provides an item that can be replaced at organizational or intermediate levels of maintenance.
- KB - Item included in both a depot overhaul/repair kit and a maintenance kit.
- MO - Item to be manufactured or fabricated at organizational level.
- MF - Item to be manufactured or fabricated at the direct support maintenance level.
- MH - Item to be manufactured or fabricated at the general support maintenance level.
- MD - Item to be manufactured or fabricated at the depot maintenance level.
- AO - Item to be assembled at organizational level.
- AF - Item to be assembled at direct support maintenance level.
- AD - Item to be assembled at depot maintenance level.
- XA - Item is not procured or stocked because the requirements for the item will result in

the replacement it of the next higher assembly.

XB - Item is not procured or stocked. If not available through salvage, requisition.

XD - A support item that is not stocked. When required, item will be procured through normal supply channels.

NOTE

Cannibalization or salvage may be used as a source of supply for any items source coded above except those coded XA, XD, and aircraft support items as restricted by AR 700-42.

(2) *Maintenance Code.* Maintenance codes are assigned to indicate the levels of maintenance authorized to USE and REPAIR support items. The maintenance codes are entered in the third and fourth positions of the Uniform SMR Code format as follows:

(a) The maintenance code entered in the third position will indicate the lowest maintenance level authorized to remove, replace, and use the support item. The maintenance code entered in the third position will indicate one of the following levels of maintenance:

Code	Application/Explanation
C	- Crew or operator maintenance performed within organizational maintenance.
O	- Support item is removed, replaced, used at the organizational level.
I	- Support item is removed, replaced, used by the direct support element of integrated direct support maintenance.
F	- Support item is removed, replaced, used at the direct support level.

NOTE

Codes "I" and "F" will be considered the same by direct support units.

(b) The maintenance code entered in the fourth position indicates whether the item is to be repaired and identifies the lowest maintenance level with the capability to perform complete repair (i.e., all authorized maintenance functions). This position will contain one of the following maintenance codes:

Code	Application Explanation
O	- The lowest maintenance level capable of complete repair of the support item is the organizational level.
F	- The lowest maintenance level capable of complete repair of the support item is the direct support level.
L	- Repair restricted to designated specialized repair activity.
Z	- Nonreparable. No repair is authorized.
B	- No repair is authorized. The item may be reconditioned by adjusting, lubricating, etc., at the user level. No parts or special tools are procured for the maintenance of this item.

(3) *Recoverability Code.* Recoverability codes are assigned to support items to indicate the disposition action on unserviceable items.

The recoverability code is entered in the fifth position of the Uniform SMR Code format as follows:

Recoverability Code	Definition
Z	- Nonreparable item. When unserviceable, condemn and dispose at the level indicated in position 3.
O	- Repairable item. When uneconomically repairable, condemn and dispose at organizational level.
F	- Repairable item. When uneconomically repairable, condemn and dispose at the direct support level.
H	- Repairable item. When uneconomically repairable, condemn and dispose at the general support level.
D	- Repairable item. When beyond lower level repair capability, return to depot. Condemnation and disposal not authorized below depot level.
L	- Repairable item. Repair, condemnation, and disposal not authorized below depot/specialized repair activity level.
A	- Item requires special handling or condemnation procedures because of specific reasons (i.e., precious metal content, high dollar value, critical material or hazardous material). Refer to

appropriate manuals/directives for specific instructions.

c. *National Stock Number.* Indicates the National stock number assigned to the item and will be used for requisitioning purposes.

d. *Part Number.* Indicates the primary number used by the manufacturer (individual, company, firm, corporation, or Government activity), which controls the design and characteristics of the item by means of its engineering drawings, specifications standards, and inspection requirements, to identify an item or range of items. For BIIL and ITIAL, see explanation of description column, par. f.

NOTE

When a stock numbered item is requisitioned, the repair part received may have a different part number than the part being replaced.

e. *Federal Supply Code for Manufacturer (FSCM).* The FSCM is a 5-digit numeric code listed in SB 708-42 which is used to identify the manufacturer, distributor, or Government agency, etc. For BIIL and ITIAL, see explanation of description column, par. f.

f. *Description.* Indicates the Federal item name and, if required, a minimum description to identify the item. The last line for each item in the BIIL and ITIAL indicates the part number with the FSCM in parentheses.

g. *Unit of Measure (U/M).* Indicates the standard of the basic quantity of the listed item as used in performing the actual maintenance function. This measure is expressed by a two-character alphabetical abbreviation (e.g. ea, in, pr, etc.). When the unit of measure differs from the unit of issue, the lowest unit of issue that will satisfy the required units of measure will be requisitioned.

h. *Quantity Furnished with Equipment (Basic Issue Items Only).* Indicates the quantity of the basic issue item furnished with the equipment.

i. *Quantity, Authorized (Items Troop Installed or Authorized Only).* Indicates the quantity of the item authorized to be used with the equipment.

j. *Quantity Incorporated in Unit.* Indicates the quantity of the item used in the breakout shown on the illustration figure, which is prepared for a functional group, subfunctional group, or an assembly. A "V" appearing in this column in lieu of a quantity indicates that no specific quantity is applicable, (e.g., shims, spacers, etc).

C-4. Special Information.

a. Usable on codes are shown in description U column. Uncoded items are applicable to all kits. Identification of the usable on codes in this publication are:

Code	Used On
PLA	KIT, ARTILLERY TRAINER: 11578585, 11578586, 11578589, and 11579628
PLB	KIT, ARTILLERY TRAINER: 11578587, 11578590, and 11579627
PLC	KIT, ARTILLERY TRAINER: 11578584, 11578586, and 11578593
PLD	KIT, ARTILLERY TRAINER: 11578584, 11578585, 11578586, 11578587, 11578588, 11578589, 11578590, and 11578593
PLE	KIT, ARTILLERY TRAINER: 11578585 and 11578589
PLF	KIT, ARTILLERY TRAINER: 11578585, 11578586, 11578587, 11578589, 11578590, and 11578593
PLG	KIT, ARTILLERY TRAINER: 11578584, 11578585, 11578587, 11578588, 11578589, and 11578590
PLH	KIT, ARTILLERY TRAINER: 11578584, 11578585, 11578586, 11578587, 11578588, 11578589, 11578590, 11578591, and 11578593
PLI	KIT, ARTILLERY TRAINER: 11578584, 11578585, 11578586, 11578587, 11578588, 11578589, 11578590, 11578592, and 11578593
PLJ	KIT, ARTILLERY TRAINER: 11578585, 11578586, 11578588, 11578589, and 11578592
PLK	KIT, ARTILLERY TRAINER: 11578584 and 11578593
PLL	KIT, ARTILLERY TRAINER: 11578584, 11578586, 11578589, and 11578593
PLM	KIT, ARTILLERY TRAINER: 11578588 and 11578590
PLN	KIT, ARTILLERY TRAINER: 11578587, 11578588, 11578590, 11578591, and 11578592
PLO	KIT, ARTILLERY TRAINER: 11578587, 11578590, 11578592, and 11578593
PLP	KIT, ARTILLERY TRAINER: 11578585, 11578586, 11578588, 11578589, and 11578590

PLQ	KIT, ARTILLERY TRAINER: 11579626, 11579627,
PLR	KIT, ARTILLERY TRAINER: 11578584, 11578585, 11578586, 11578587, 11578588, 11578589, 11578590, 11578593, 11579626, 11579627, and 11579628
PLS	KIT, ARTILLERY TRAINER: 11578585, 11578586, 11578589, 11579626, 11579627, and 11579628

b. Action change codes indicated in the left-hand margin of the listing page denote the following:

- N-Indicates an added item.
- C-Indicates a change in data.
- R-Indicates a change in NSN only.

C-5. How to Locate Repair Parts.

a. *When National Stock Number or Part Number is Unknown.*

(1) *First.* Using the table of contents, determine the subgroup within which the repair part belongs. This is necessary since illustrations are prepared for subgroups, and listings are divided into the same groups.

(2) *Second.* Find the illustration covering the subgroup to which the repair part belongs.

(3) *Third.* Identify the repair part on illustration and note the illustration figure and item number of the repair part.

(4) *Fourth.* Using the Repair Parts Listing, find the figure and item number noted on the illustration.

b. *When National Stock Number or Part Number is Known.*

(1) *First.* Using the Index of National Stock Numbers and Part Numbers, find the pertinent National stock number or part number. This index is in ascending NSN sequence followed by a list of part numbers in ascending alphameric sequence, cross-referenced to the illustration figure number and item number.

(2) *Second.* After finding the figure and item number, locate the figure and item number in the repair parts list.

Section II. BASIC ISSUE ITEM LIST

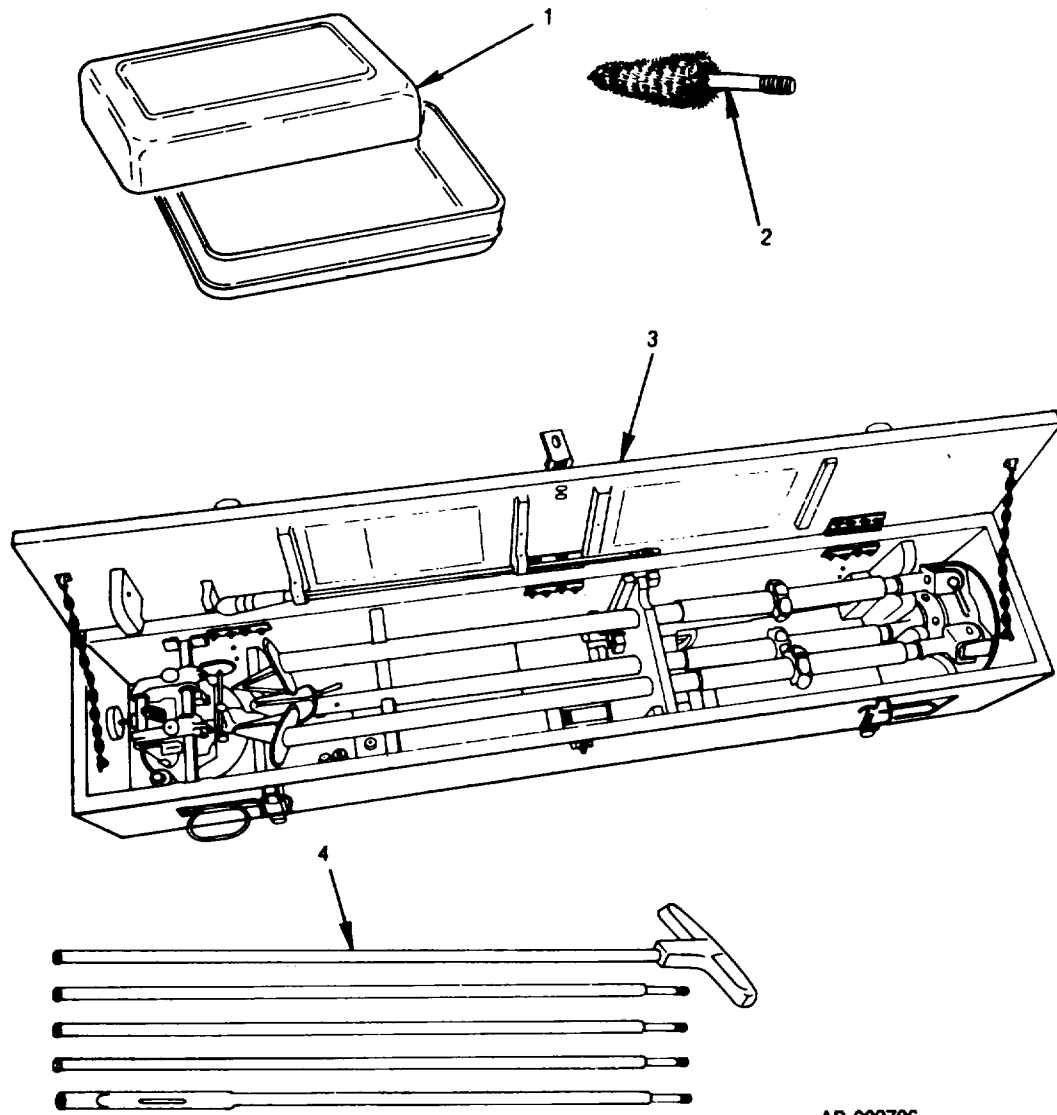

AR 902796

Figure C-1. Basic issue items

(1) ILLUSTRATION		(2) NATIONAL STOCK NUMBER	(3) DESCRIPTION		(4) QTY FURN WITH EQUIP
(A) FIG.	(B) ITEM		PART NUMBER	USABLE ON CODE	
C-1	1	7620-00-935-9815	BOX, PLASTIC (L-B-00566) (81348)		1
C-1	2	1005-00-508-2589	BRUSH, BRONZE (8407954) (19204)		1
C-1	3	6920-01-040-1486	CHEST, METAL, M31 TRAINER (11578763) (19206)		1
C-1	4	1005-00-653-5441	ROD, CLEANING (6535441) (19204)		1

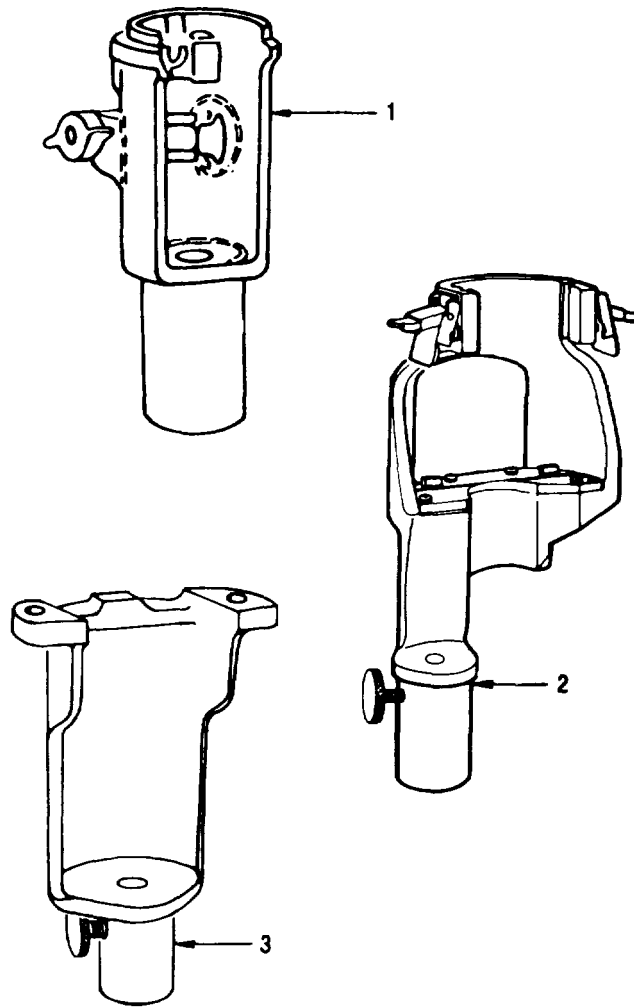

AR 902797

Figure C-2. Basic issue items- continued

(1) ILLUSTRATION (A) FIG.	(B) ITEM	(2) NATIONAL STOCK NUMBER	(3) DESCRIPTION		(4) QTY FURN WITH EQUIP
			PART NUMBER	USABLE ON CODE	
C-2	1	6920-00-378-9823 OR	SOCKET ASSY: FOR M12A7 TELESCOPE (11578700) PLN (19206)	OR	1
C-2	2	6920-00-378-9824 OR	SUPPORT ASSY: FOR M117 TELESCOPE (11728907) PLE (19200)	OR	
C-2	3	6920)00-46-5968	HOLDER ASSY: FOR M113/M115S TELESCOPE (11727520) (D1104)	PLL	

Change 1 C-6

Section III. ITEMS TROOP INSTALLED OR AUTHORIZED

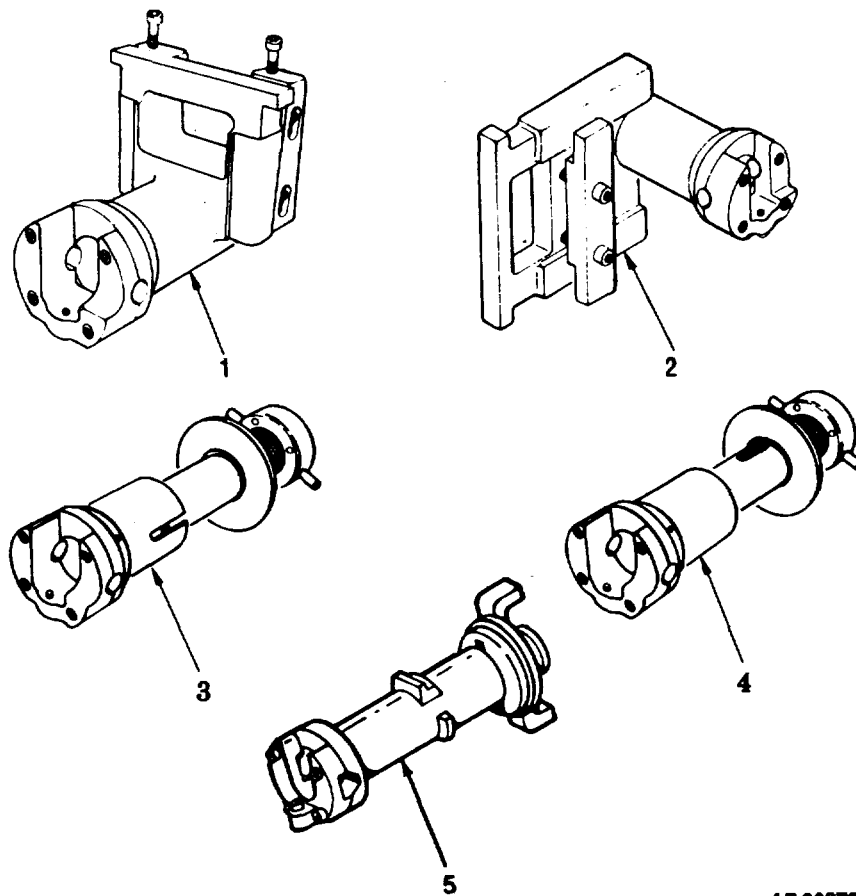

AR 902798

Figure C-3. Items troop installed or authorized

(1) ILLUSTRATION		(2) NATIONAL STOCK NUMBER	(3) DESCRIPTION		(4) QTY FURN WITH EQUIP
(A) FIG.	(B) ITEM		PART NUMBER	USABLE ON CODE	
		6920-00-603-9301	KIT, ARTILLERY TRAINER: 11578584, 11578585, 11578586, 11578587, 11578588, 11578589, 11578590, 11578591, 11578592, 11578593.		2
C-3	1	6920-00-095-2578	TRAINER, M31: 11578676 (19206)		6
C-3	2	6920-00-345-8947	ADAPTER ASSEMBLY, M102: 11578750 (19206)	PLK	6
C-3	3	6920-00-345-8949	ADAPTER ASSEMBLY, M101A1: 11578749(19206)	PLB	6
			ADAPTER ASSEMBLY, M114, M114A1: 11578752 (19206)	PLM	6
C-3	4	6920-00-095-2576	ADAPTER ASSEMBLY, M109, M109AI, M107, M110: 11578780(19206)	PLA	6
C-3	5	6920-01-117-3637	ADAPTER ASSEMBLY, M198: 11579605 (19206)	PLQ	6

Change 2 C-7

(1) NATIONAL STOCK NUMBER	(2) DESCRIPTION FSCM AND PART NUMBER	USABLE ON CODE	(3) U/M	(4) QTY AUTH
	ARTILLERY TRAINER-Continued			
7520-00-990-1452	BOX, PLASTIC: L-B-00565 (81348)		EA	1
1290-00-275-1700	CARTRIDGE ASSEMBLY (FADAC): 8213330		EA	2
	CASE, SHIPPING & STORAGE: 11578765 (19206)	PLF	EA	3
	CASE, SHIPPING & STORAGE: 11578767 (19206)	PLC	EA	6
	CASE, SHIPPING & STORAGE: 11578769 (19206)	PLG	EA	2
	CASE, SHIPPING & STORAGE: 11578770(19206)		EA	1
1220-00-442-2446	GRAPHICAL FIRING TABLE: 10557266		EA	13
1220-00-221-6328	GRAPHICAL SITE TABLE: 11729002		EA	10
6920-00-295-8113	GUN ASSEMBLY (less sector gear): 11578634 (19206)	PLD	EA	4
6920-00-867-5317	KNOB, BOLT LOCK: 11578617(19206)		EA	1
6920-00-095-2577	LANYARD RING ASSEMBLY: 11578753 (19206)	PLD	EA	12
	NUT, SELF-LOCKING: 11578678 (19206)		EA	2
6920-00-867-5301	PIN, FIRING: 11578606(19206)		EA	1
6920-00-867-5300	PLUNGER, BOLT LEVER: 11578609 (19206)		EA	1
6920-00-867-5314	PLUNGER, BOLT LOCK: 11578624 (19206)		EA	1
5120-00-245-7047	SAFETY TONGS: GGG-T-546		EA	2
5360-00-950-2997	SPRING, BOLT LOCK: MS24585-C80 (19206)		EA	1
6920-00-867-5305	SPRING, HELICAL COMPRESSION: 11578613(19206)		EA	1
5360-00-925-7852	SPRING. PLUNGER: MS24585-C12 (96906)		EA	1
6920-00-867-5315	STOP, BOLT LOCK: 11578633 (19206)		EA	1
	TABULAR FIRING TABLE:		EA	10
5120-00-224-4659	WRENCH, ALLEN 1/4": GGG-K-275	PLI	EA	1
5120-00-889-2162	WRENCH, ALLEN 7/64": GGG-K-275	PLJ	EA	1
5120-00-240-5300	WRENCH, ALLEN 3/16": GGG-T-546	PLH	EA	1
5120-00-198-5391	WRENCH, ALLEN 1/2": GGG-K-275	PLO	EA	1

Change 2 C-8

Section IV. REPAIR PARTS LIST

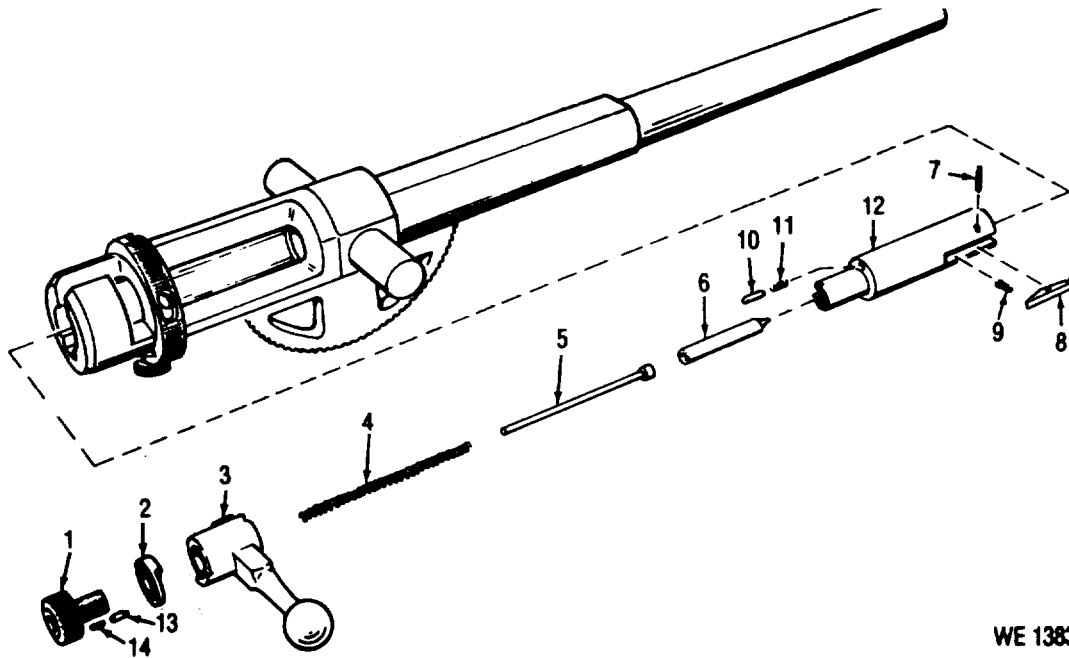

WE 13835

Figure C-4. Breechbolt group - exploded view

(1) ILLUSTRATION		(2)	(3)	(4)	(5)	(6)	(7)	(8)
(a) FIG NO.	(b) ITEM NO.	SMR CODE	NATIONAL STOCK NUMBER	PART NUMBER	FSCM	DESCRIPTION USABLE ON CODE	U/M	QTY INC IN UNIT
						BREECH BOLT GROUP		
C-4	1	PAOZZ	5305-00-069-8701	11578612	19206	SCREW, BREECH BOLT	EA	1
C-4	2	PAOZZ	6920-00-867-5308	11578578	19206	SPACER, DETENT	EA	1
C-4	3	PAFZZ	6920-00-868-5662	11578601	19206	LEVER, BREECH BOLT, TRAINER	EA	1
C-4	4	PAOZZ	5360-00-867-5303	11578613	19206	SPRING, HELICAL, COMPRESSION: firming pin	EA	1
C-4	5	PAOZZ	6920-00-867-5302	11578610	19206	GUIDE, FIRING PIN SPRING, TRAINER	EA	1
C-4	6	PAOZZ	6920-00-867-5301	11578606	19206	FIRING PIN, TRAINER: breech bolt	EA	1
C-4	7	PAOZZ	6920-00-867-5297	11578631	19206	PIN, EXTRACTOR, TRAINER	EA	1
C-4	8	PAOZZ	6920-00-867-8879	11578608	19206	EXTRACTOR, TRAINER	EA	1
C-4	9	PAOZZ	5360-00-993-7572	MS24585-C10	96906	SPRING	EA	1
C-4	10	PAOZZ	6920-00-867-5300	11578609	19206	PLUNGER, BOLT LEVER	EA	1
C-4	11	PAOZZ	6920-00-926-7862	MS24585-C12	96906	SPRING, PLUNGER	EA	1
C-4	12	PBFZZ	6920-00-867-5296	11578600	19206	BREECH BOLT, TRAINER	EA	1
C-4	13	PAOZZ	6920-00-927-1157	11578611	19206	PLUNGER, BARREL ASSEMBLY	EA	1
C-4	14	PAOZZ	5360-00-993-7572	MS24585-C10	96906	SPRING	EA	1

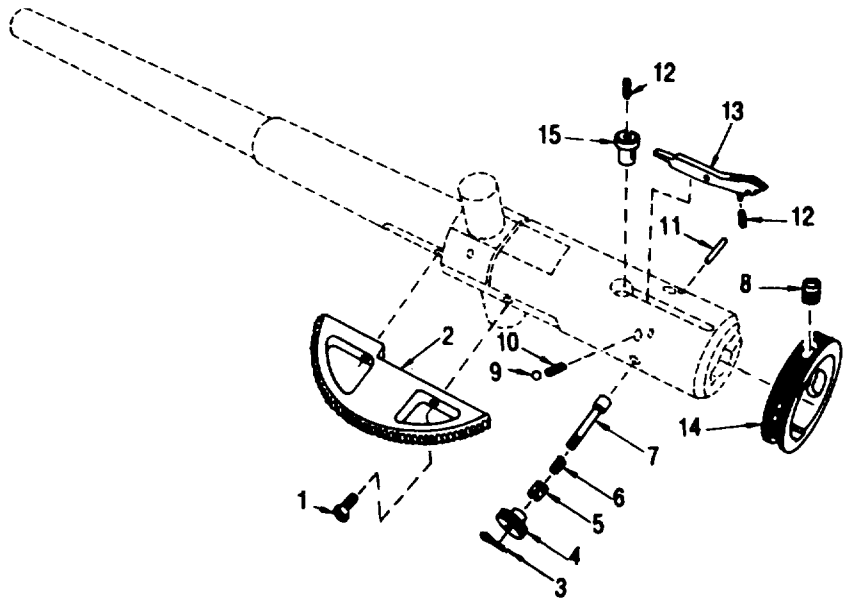

AR 902727

Figure C-5. Barrel assembly - partial exploded view

(1) ILLUSTRATION		(2)	(3)	(4)	(5)	(6)	(7)	(8)
(a) FIG NO.	(b) ITEM NO.	SMR CODE	NATIONAL STOCK NUMBER	PART NUMBER	FSCM	DESCRIPTION USABLE ON CODE	U/M	QTY INC IN UNIT
C-5	1	PAOZZ	5305-00-069-8703	11578764	19206	BARREL ASSEMBLY SCREW, GEAR SECTOR: elevating, barrel assembly	EA	2
C-5	2	PAOZZ	6920-00-867-5320	11578695	19206	GEAR SECTOR: elevating, barrel	EA	1
C-5	3	PAOZZ	5315-00-236-8345	MS24665-5	96906	PIN, COTTER	EA	1
C-5	4	PAOZZ	6920-00-867-5317	11578617	19206	KNOB, BOLT, LOCK	EA	1
C-5	5	PAOZZ	6920-00-867-5318	11578623	19206	BUSHING, BOLT LOCK	EA	1
C-5	6	PAOZZ	5360-00-950-2997	MS24585-C80	96906	SPRING, BOLT LOCK	EA	1
C-5	7	PAOZZ	6920-00-867-5314	11578624	19206	PLUNGER, BOLT LOCK	EA	1
C-5	8	PAOZZ	5305-00-069-8702	11578622	19206	SCREW, SAFETY STOP	EA	1
C-5	9	PAOZZ	6920-00-867-5306	11578632	19206	BALL, BEARING, SAFETY DETENT	EA	1
C-5	10	PAOZZ	5360-00-950-2997	MS24585-C80	96906	SPRING, BOLT, LOCK	EA	1
C-5	11	PAOZZ	6920-00-867-5294	11578630	19206	PIN, TRIGGER, TRAINER	EA	1
C-5	12	PAOZZ	5360-00-867-5311	MS24585-C49	96906	SPRING, HELICAL, COMPRESSION	EA	3
C-5	13	PAOZZ	6920-00-867-5309	11578628	19206	TRIGGER, TRAINER	EA	1
C-5	14	PAFZZ	6920-00-867-5313	11578607	19206	SAFETY, ARTILLERY TRAINER	EA	1
C-5	15	PAOZZ	6920-00-867-5310	11578604	19204	GUIDE, BOLT, TRAINER	EA	1

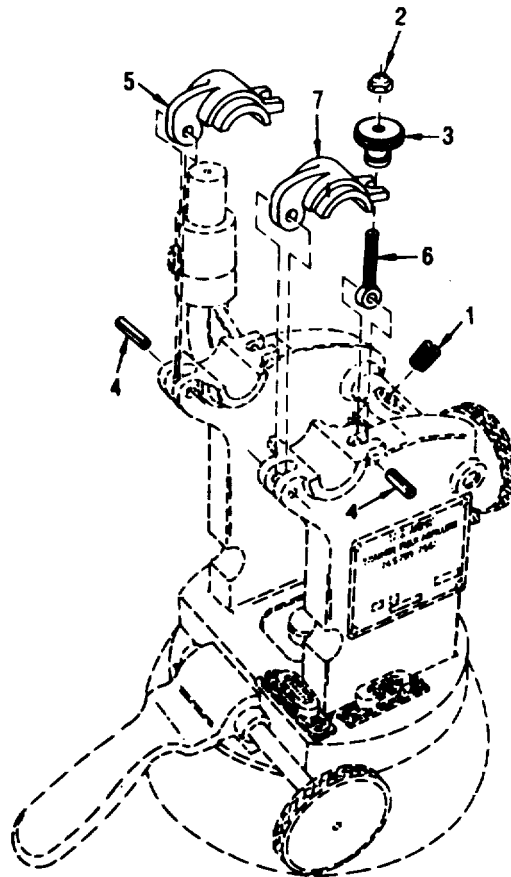

AR 902729

Figure C-6. Trunnion caps

(1) ILLUSTRATION		(2)	(3)	(4)	(5)	(6)	(7)	(8)
(a) FIG NO.	(b) ITEM NO.	SMR CODE	NATIONAL STOCK NUMBER	PART NUMBER	FSCM	DESCRIPTION USABLE ON CODE	U/M	QTY INC IN UNIT
C-6	1	PAFZZ	5305-00-069-8700	11578657	19206	TRUNNION CAPS SCREW, ADJUSTING, WORM WHEEL: elevating bracket	EA	1
R C-6	2	PAFZZ	5310-01-056-7463	11578678	19206	STOPNUT	EA	2
C-6	3	PAFZZ	6920-00-867-5271	11578640	19206	KNOB, TRUNNION CAP LOCK	EA	2
C-6	4	PAFZZ	6920-00-867-5253	11578645	19206	PIN, SPRING	EA	4
C-6	5	PAFZZ	6920-00-867-5252	11578646	19206	CAP, TRUNNION, LEFT	EA	1
C-6	6	PAFZZ	5305-00-069-8692	11578638	19206	SCREW, TRUNNION CAP LOCK	EA	2
C-6	7	PAFZZ	6920-00-867-5255	11578647	19206	CAP. TRUNNION, RIGHT	EA	1

Change 1 C-11

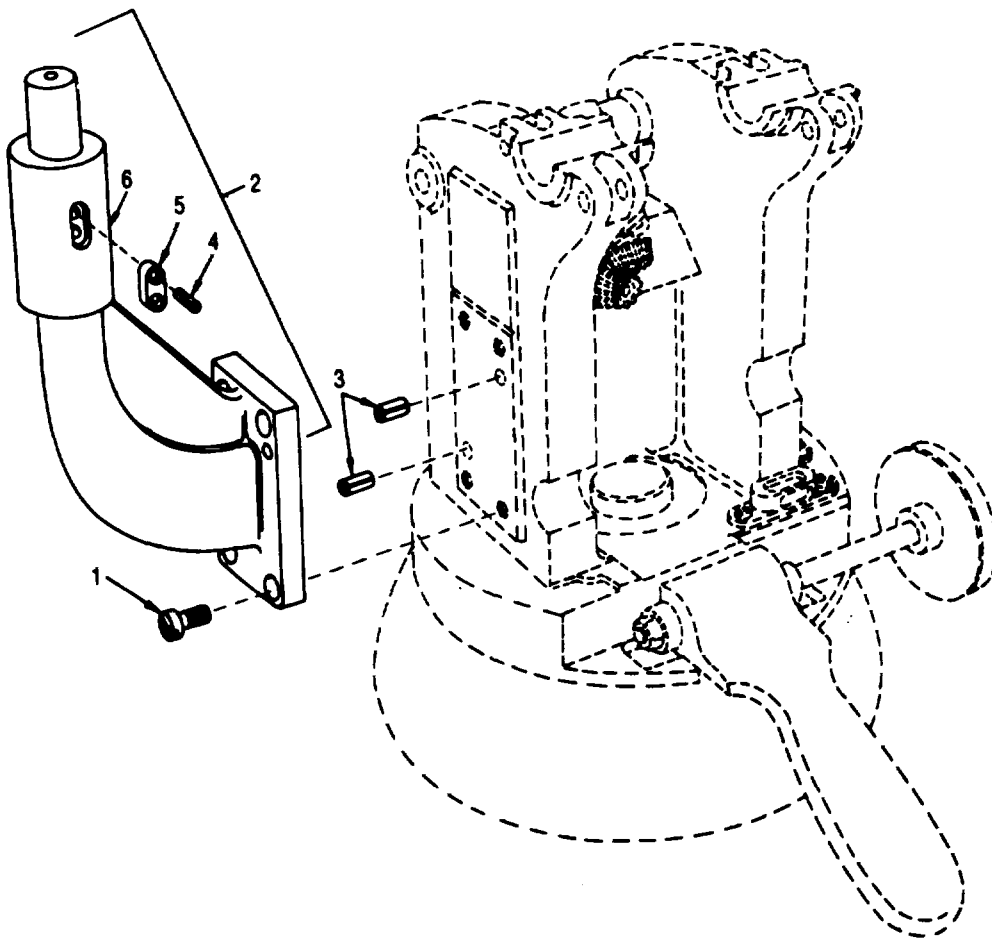

AR 902728

Figure C-7. Telescope bracket removed from mount

(1) ILLUSTRATION		(2)	(3)	(4)	(5)	(6)	(7)	(8)
(a) FIG NO.	(b) ITEM NO.	SMR CODE	NATIONAL STOCK NUMBER	PART NUMBER	FSCM	DESCRIPTION USABLE ON CODE	U/M	QTY INC IN UNIT
C-7	1	PAFZZ	5305-00-069-8698	11578746	19206	TELESCOPE BRACKET SCREW, TELESCOPE BRACKET	EA	4
C-7	2	AFFZZ		11578714	19206	BRACKET ASSEMBLY, TELESCOPE	EA	1
C-7	3	PAFZZ	6920-00-867-5284	11578747	19206	PIN, SPRING	EA	2
C-7	4	PAFZZ		11578715	19206	PIN, SPRING	EA	2
C-7	5	PAFZZ	6920-00-867-5334	11578716	19206	KEY, TELESCOPE SOCKET BRACKET	EA	1
C-7	6	PAFZZ	6920-00-867-5283	11578659	19206	BRACKET. TELESCOPE SOCKET	EA	1

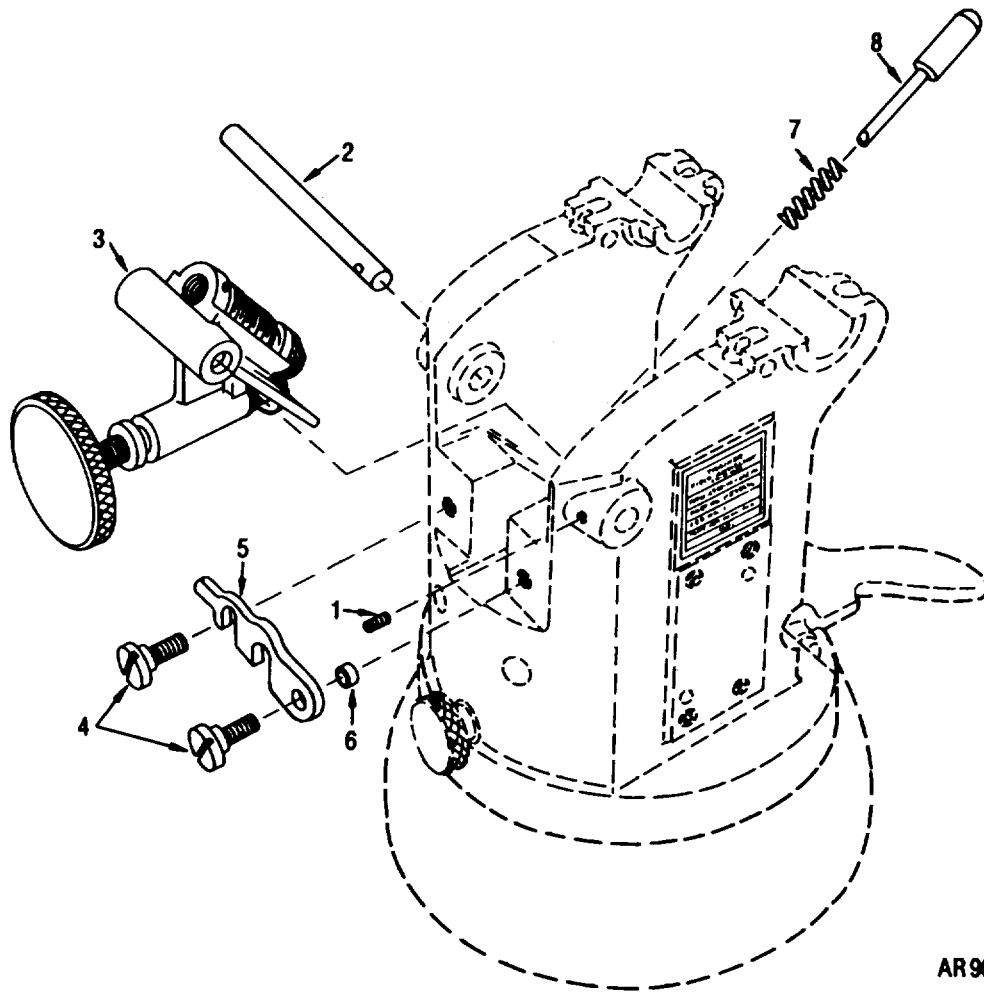

AR 902730

Figure C-8. Mount assembly - partial exploded view

(1) ILLUSTRATION (a) FIG NO. (b) ITEM NO.		(2) SMR CODE	(3) NATIONAL STOCK NUMBER	(4) PART NUMBER	(5) FSCM	(6) DESCRIPTION USABLE ON CODE	(7) U/M	(8) QTY INC IN UNIT
C-8	1	PAFZZ	6920-00-867-5270	11578669	19206	MOUNT ASSEMBLY SETSCREW, ELEVATING BRACKET SHAFT: pivot	EA	1
C-8	2	PAFZZ	6920-00-867-5269	11578655	19206	SHAFT, ELEVATING BRACKET:	EA	1
C-8	3	AFFZZ		11578754		BRACKET ASSEMBLY: elevating	EA	1
C-8	4	PAFZZ	5305-00-069-8698	11578636	19206	SCREW, LOCKING: elevating plate	EA	2
C-8	5	PAFZZ	6920-00-867-5285	11578648	19206	PLATE, LOCKING: rapid elevating	EA	1
C-8	6	XBFZZ		11578713		SLEEVE, LOCKING:	EA	2
C-8	7	PAFZZ	5360-00-867-5257	MS24585-C282	96906	SPRING, HELICAL COMPRESSION	EA	2
C-8	8	XBFZZ	6920-00-867-5304	11578649	19206	PLUNGER, ELEVATING BRACKET	EA	2

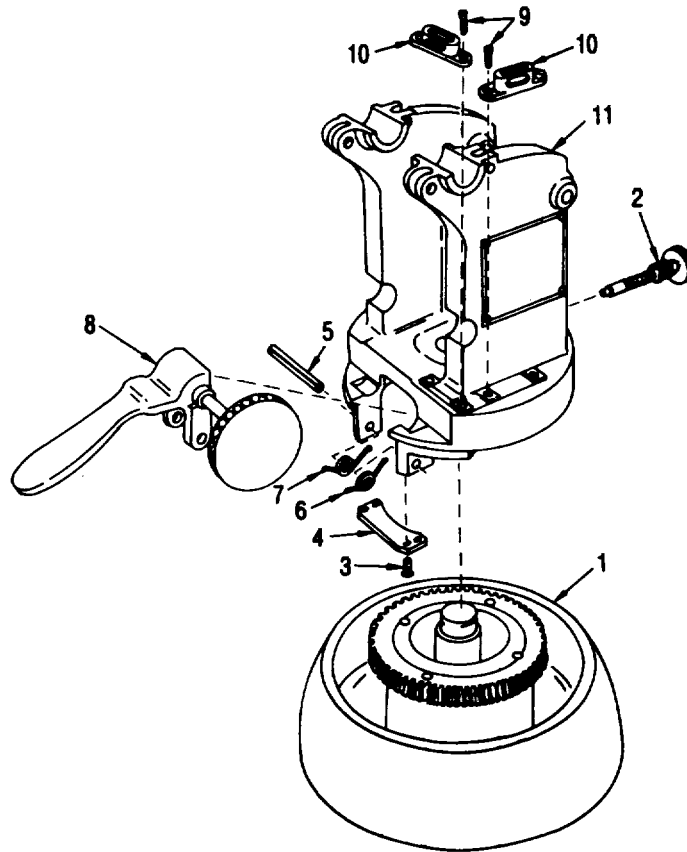

AR 902731

Figure C-9. Mount assembly - partial exploded view

(1) ILLUSTRATION		(2)	(3)	(4)	(5)	(6)	(7)	(8)
(a) FIG NO.	(b) ITEM NO.	SMR CODE	NATIONAL STOCK NUMBER	PART NUMBER	FSCM	DESCRIPTION USABLE ON CODE	U/M	QTY INC IN UNIT
C-9	1	AFFFF		11578756		MOUNT ASSEMBLY	EA	1
C-9	2	AFFFF		11578757		FIXED BASE MOUNT ASSEMBLY	EA	1
C-9	3	PAFZZ	5305-00-069-8694	11578662	19206	PLUNGER LOCKING ASSEMBLY	EA	4
C-9	4	PAFZZ	6920-00-867-8878	11578644	19206	SCREW, PLATE	EA	1
C-9	5	PAFZZ	6920-00-867-5276	11578615	19206	PLATE	EA	1
C-9	6	PAFZZ	5360-00-867-5280	11578642	19206	PIN, SPRING	EA	1
C-9	7	PAFZZ	5360-00-867-5281	11578641	19206	SPRING, HELICAL, TORSION: traversing lever, left	EA	1
C-9	8	AFFFF		11578755		SPRING, HELICAL, TORSION: LEVER, RAPID TRAVERSE, ASSY	EA	1
C-9	9	PAFZZ	5305-00-069-8691	11578679	19206	SCREW, LEVEL VIAL	EA	4
C-9	10	PAFZZ	6920-00-867-5286	11578654	19206	VIAL, LEVEL, ARTILLERY TRAINER	EA	2
C-9	11	XAOZZ		11578620	19206	MOUNT, UPPER	EA	1

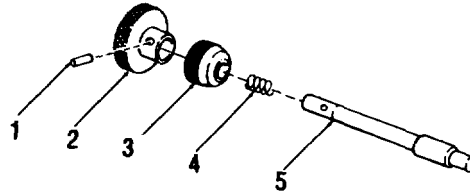

AR 902732

Figure C-10. Plunger locking assembly - exploded view

(1) ILLUSTRATION		(2) SMR CODE	(3) NATIONAL STOCK NUMBER	(4) PART NUMBER	(5) FSCM	(6) DESCRIPTION USABLE ON CODE	(7) U/M	(8) QTY INC IN UNIT
(a) FIG NO.	(b) ITEM NO.							
C-10	1	PAFZZ	6920-00-867-5259	11578680	19206	PLUNGER LOCKING ASSY PIN, SPRING	EA	1
C-10	2	PAFZZ	6920-00-867-5249	11578618	19206	KNOB, PLUNGER LOCKING	EA	1
C-10	3	PAFZZ	6920-00-867-5246	11578637	19206	BUSHING, PLUNGER LOCKING	EA	1
C-10	4	PAFZZ	5360-00-867-5251	11578660	19206	SPRING, HELICAL COMPRESSION	EA	1
C-10	5	PAFZZ	6920-00-867-5248	11578619	19206	PLUNGER, MOUNT LOCKING	EA	1

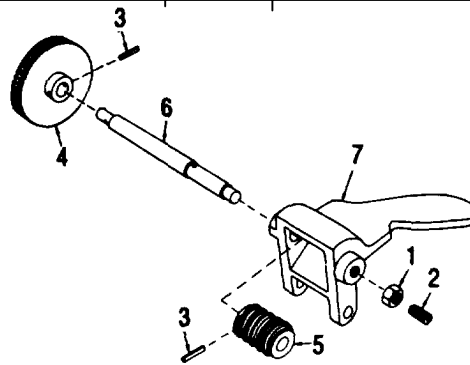

AR 902733

Figure C-11 Rapid traverse lever assembly - exploded view

(1) ILLUSTRATION		(2) SMR CODE	(3) NATIONAL STOCK NUMBER	(4) PART NUMBER	(5) FSCM	(6) DESCRIPTION USABLE ON CODE	(7) U/M	(8) QTY INC IN UNIT
(a) FIG NO.	(b) ITEM NO.							
C-11	1	PAFZZ	6920-00-867-5279	11578664	19206	NUT, TRAVERSING SHAFT	EA	1
C-11	2	PAFZZ	6920-00-867-5278	11578665	19206	SETSCREW, TRAVERSING SHAFT	EA	1
C-11	3	PAFZZ	6920-00-867-5259	11578680	19206	PIN, SPRING	EA	2
C-11	4	PAFZZ	6920-00-867-5258	11578651	19206	HANDWHEEL: elevating and traversing	EA	1
C-11	5	PAFZZ	3020-00-867-5282	11578635	19206	GEAR, WORM	EA	1
C-11	6	PAFZZ	6920-00-867-5277	11578639	19206	SHAFT, TRAVERSING	EA	1
C-11	7	PAFZZ	6920-00-867-6588	11578661	19206	LEVER, RAPID TRAVERSING	EA	1

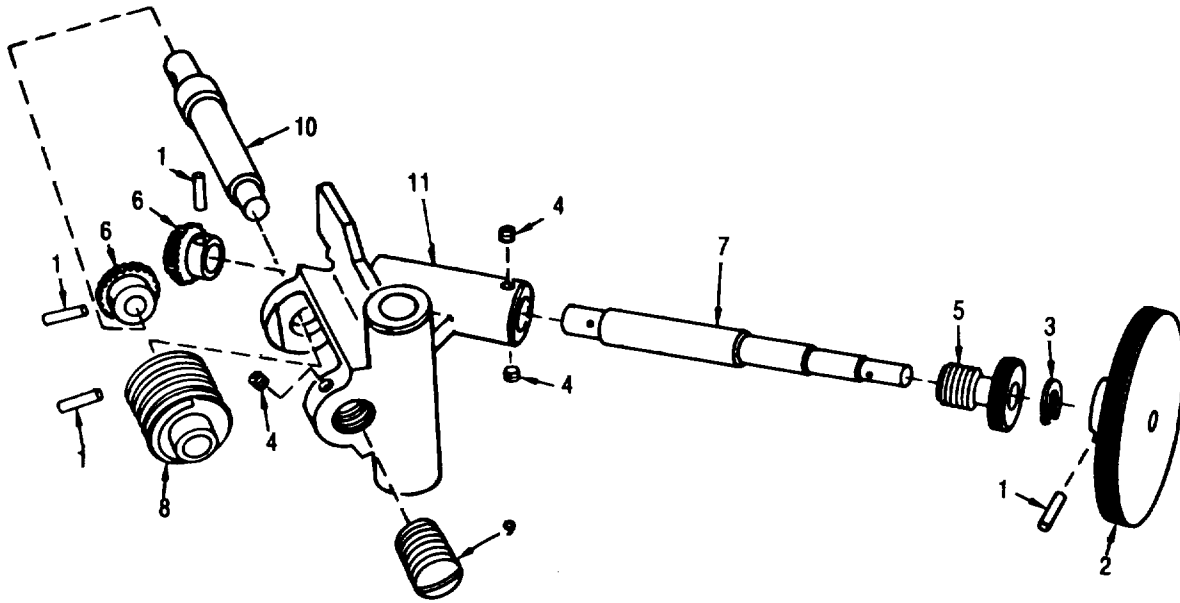

AR 902734

Figure C-12. Elevating worm glow bracket assembly- exploded view

(1) ILLUSTRATION		(2)	(3)	(4)	(5)	(6)	(7)	(8)
(a) FIG NO.	(b) ITEM NO.	SMR CODE	NATIONAL STOCK NUMBER	PART NUMBER	FSCM	DESCRIPTION USABLE ON CODE	U/M	QTY INC IN UNIT
C-12	1	PAFZZ	6920-00-867-5259	11578680	19206	ELEVATING WORM GEAR BRACKET ASSY	EA	4
C-12	2	PAFZZ	6920-00-867-5258	11578651	19206	HANDWHEEL, ELEVATING AND TRAVERSING	EA	1
C-12	3	PAFZZ	6920-00-867-5261	11578673	19206	SNAP RING: elevating shaft	EA	1
C-12	4	PAFZZ	6920-00-867-5264	11578672	19206	SETSCREW, ELEVATING SHAFT	EA	3
C-12	5	PAFZZ	6920-00-867-5262	11578658	19206	BUSHING, ELEVATING SHAFT	EA	1
C-12	6	PAFZZ	3020-00-867-5265	11578650	19206	GEAR, BEVEL: elevating shaft & worm	EA	2
C-12	7	PAFZZ	6920-00-867-5260	11578652	19206	SHAFT, ELEVATING	EA	1
C-12	8	PAFZZ	3020-00-867-5268	11578656	19206	GEAR, WORM: elevating	EA	1
C-12	9	PAFZZ	5305-00-069-8700	11578657	19206	SCREW, ADJUSTING, WORM	EA	1
C-12	10	PAFZZ	6920-00-867-5267	11578653	19206	SHAFT, ELEVATING WORM	EA	1
C-12	11	PAFZZ	6920-00-867-5263	11578709	19206	BRACKET, ELEVATING	EA	1

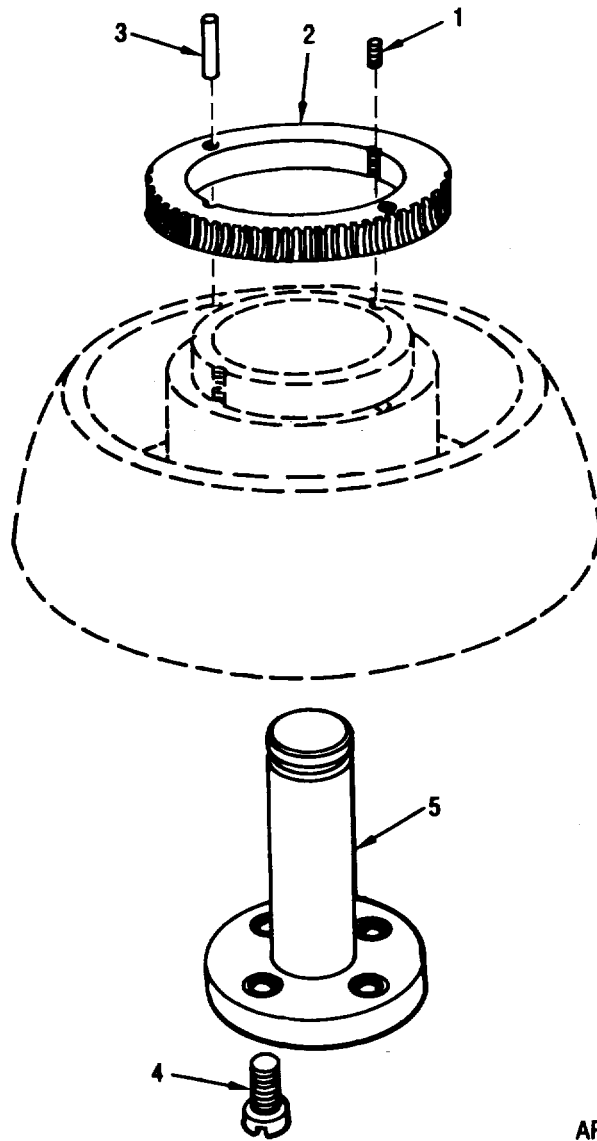

AR 902735

Figure C-13. Fixed mount base assembly - exploded view

(1) ILLUSTRATION		(2)	(3)	(4)	(5)	(6)	(7)	(8)
(a) FIG NO.	(b) ITEM NO.	SMR CODE	NATIONAL STOCK NUMBER	PART NUMBER	FSCM	DESCRIPTION USABLE ON CODE	U/M	QTY INC IN UNIT
C-13	1	PAFZZ	6920-00-867-5272	11578667	19206	FIXED BASE MOUNT ASSEMBLY	EA	2
C-13	2	PAFZZ	3020-00-867-5274	11578643	19206	SETSCREW, BOTTOM CARRIAGE	EA	1
C-13	3	PAFZZ	6920-00-867-5273	11578668	19206	GEAR, WORM WHEEL	EA	2
C-13	4	PAFZZ	5305-00-069-8693	11578666	19206	PIN, SPRING	EA	4
C-13	5	PAFZZ	6920-00-867-5275	11578621	19206	SCREW, PINTLE PIN PIN. PINTLE	EA	1

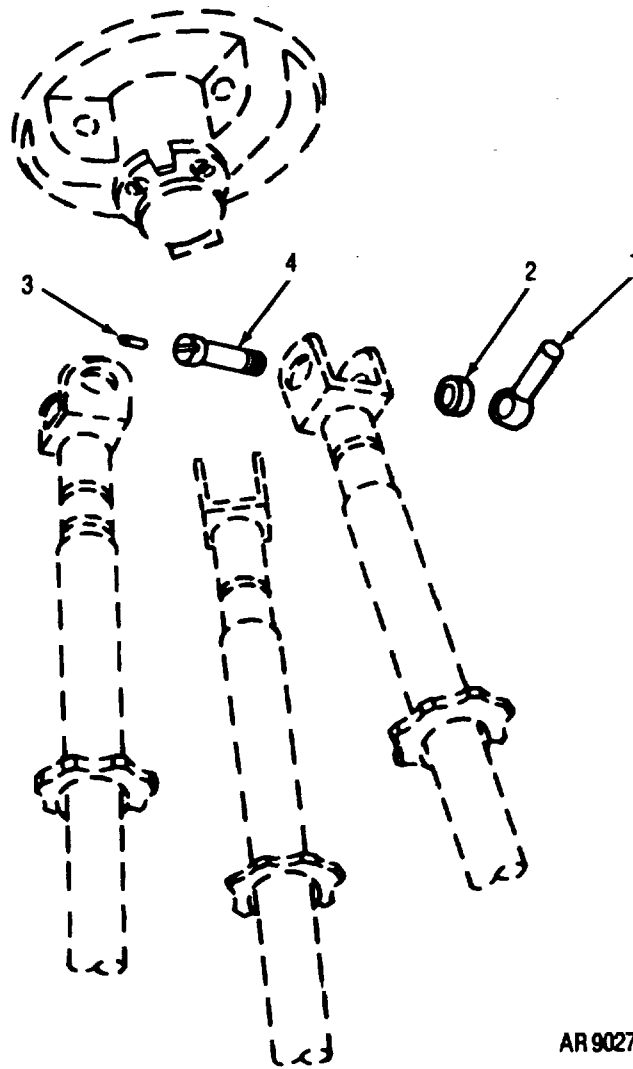
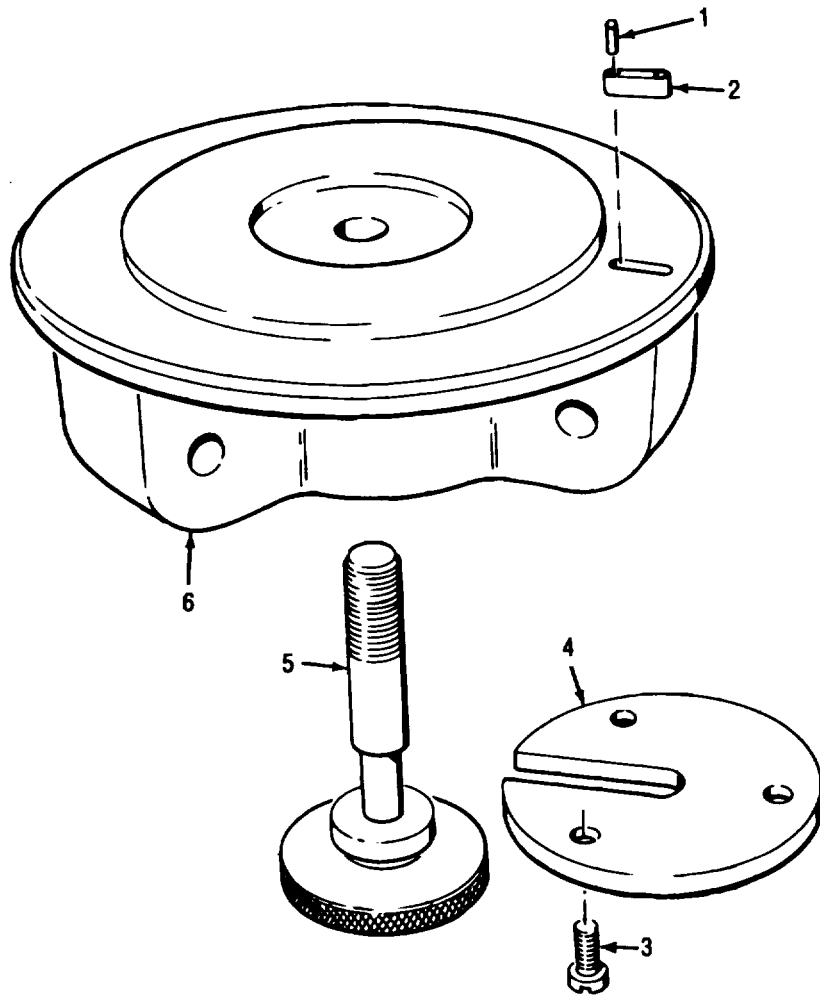

Figure C-14. Tripod locking lever group - exploded view

(1) ILLUSTRATION		(2)	(3)	(4)	(5)	(6)	(7)	(8)
(a) FIG NO.	(b) ITEM NO.	SMR CODE	NATIONAL STOCK NUMBER	PART NUMBER	FSCM	DESCRIPTION USABLE ON CODE	U/M	QTY INC IN UNIT
C-14	1	PAFZZ	6920-00-867-5324	11578691	19206	TRIPOD MOUNT ASSEMBLY	EA	3
C-14	2	PAFZZ	6920-00-867-5323	11578681	19206	LEVER, LEG LOCKING	EA	3
C-14	3	PAFZZ	6920-00-867-5272	11578667	19206	SPACER, LOCKING LEVER	EA	3
C-14	4	PAFZZ	5306-00-871-8488	11578693	19206	SETSCREW, LOCKING BOLT BOLT, LOCKING	EA	3



AR 902737

Figure C-15. Tripod base assembly - exploded view

(1) ILLUSTRATION		(2)	(3)	(4)	(5)	(6)	(7)	(8)
(a) FIG NO.	(b) ITEM NO.	SMR CODE	NATIONAL STOCK NUMBER	PART NUMBER	FSCM	DESCRIPTION USABLE ON CODE	U/M	QTY INC IN UNIT
						TRIPOD BASE GROUP		
C-15	1	PAFZZ		11578715	19206	PIN, SPRING	EA	2
C-15	2	PAFZZ	6920-00-867-5334	11578716	19206	KEY, TRIPOD BASE	EA	1
C-15	3	PAFZZ	5305-00-069-8705	11578717	19206	SCREW, RETAINER: mount locking screw	EA	3
C-15	4	PAFZZ	6920-00-867-5335	11578683	19206	RETAINER, CARRIAGE MOUNTING SCREW: tripod base	EA	1
C-15	5	PAFZZ	5305-00-069-8706	11578682	19206	SCREW, MOUNT LOCKING: tripod base	EA	1
C-15	6	PAFZZ	6920)00-867-5333	11578689	19206	BASE, TRIPOD	EA	1

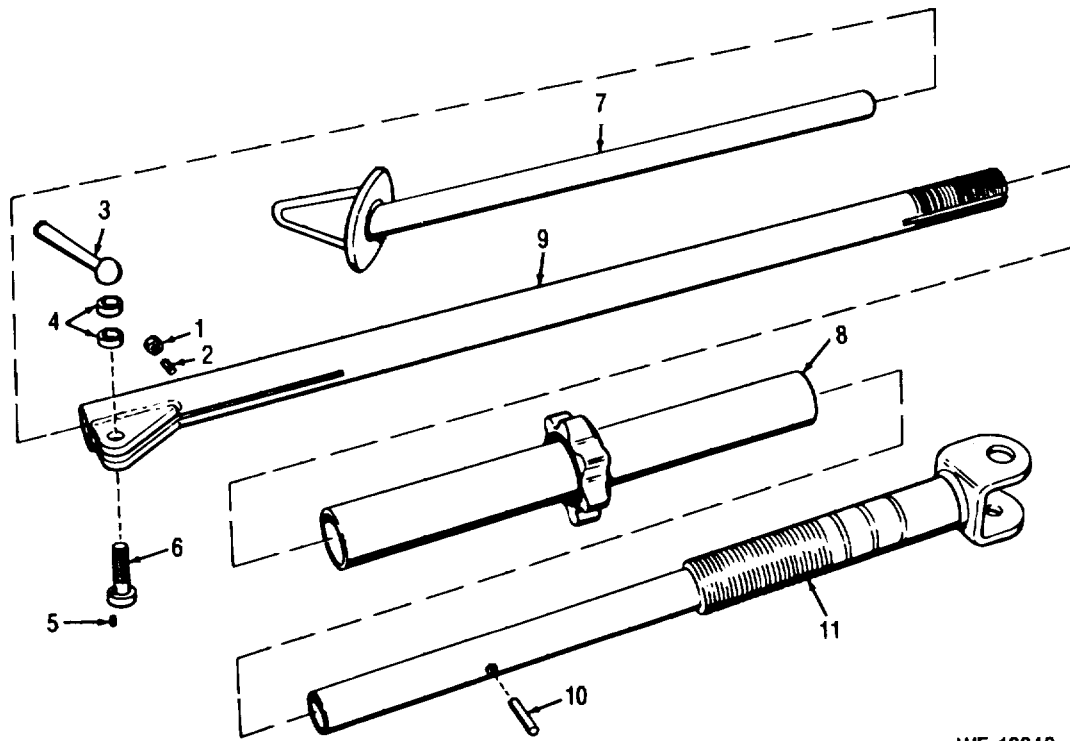

WE 13848

Figure C-16. Tripod lower rear leg group - exploded view

(1) ILLUSTRATION		(2)	(3)	(4)	(5)	(6)	(7)	(8)
(a) FIG NO.	(b) ITEM NO.	SMR CODE	NATIONAL STOCK NUMBER	PART NUMBER	FSCM	DESCRIPTION USABLE ON CODE	U/M	QTY INC IN UNIT
C-16	1	PAOZZ	6920-00-867-5330	11578712	19206	TRIPOD LOWER REAR LEG GROUP	EA	1
C-16	2	PAOZZ	5305-00-069-8704	11578711	19206	NUT, GUIDE SCREW: lower rear leg	EA	1
C-16	3	PAFZZ	6920-00-867-5324	11578691	19206	SCREW, GUIDE: lower rear leg	EA	3
C-16	4	PAFZZ	6920-00-867-5323	11578681	19206	LEVER, LEG LOCKING	EA	3
C-16	5	PAFZZ	6920-00-867-5272	11578667	19206	SPACER, LOCKING LEVER: upper	EA	3
C-16	6	PAFZZ	5306-00-871-8490	11578694	19206	SETScrew, BOLT LOCKING	EA	3
C-16	7	PAFZZ	6920-00-867-5332	11578684	19206	BOLT, REAR EXTENSION LEG: tripod	EA	1
C-16	8	PAFZZ	6920-00-867-5326	11578692	19206	LEG, EXTENSION, REAR	EA	1
C-16	9	PAFZZ	6920-00-867-5329	11578690	19206	SLEEVE, LEG ADJUSTING	EA	1
C-16	10	PAFZZ	6920-00-867-5325	11578710	19206	LEG, LOWER REAR	EA	1
C-16	11	PAFZZ	6920-00-867-5321	11578688	19206	PIN, SPRING	EA	1
C-16						LEG, UPPER	EA	3

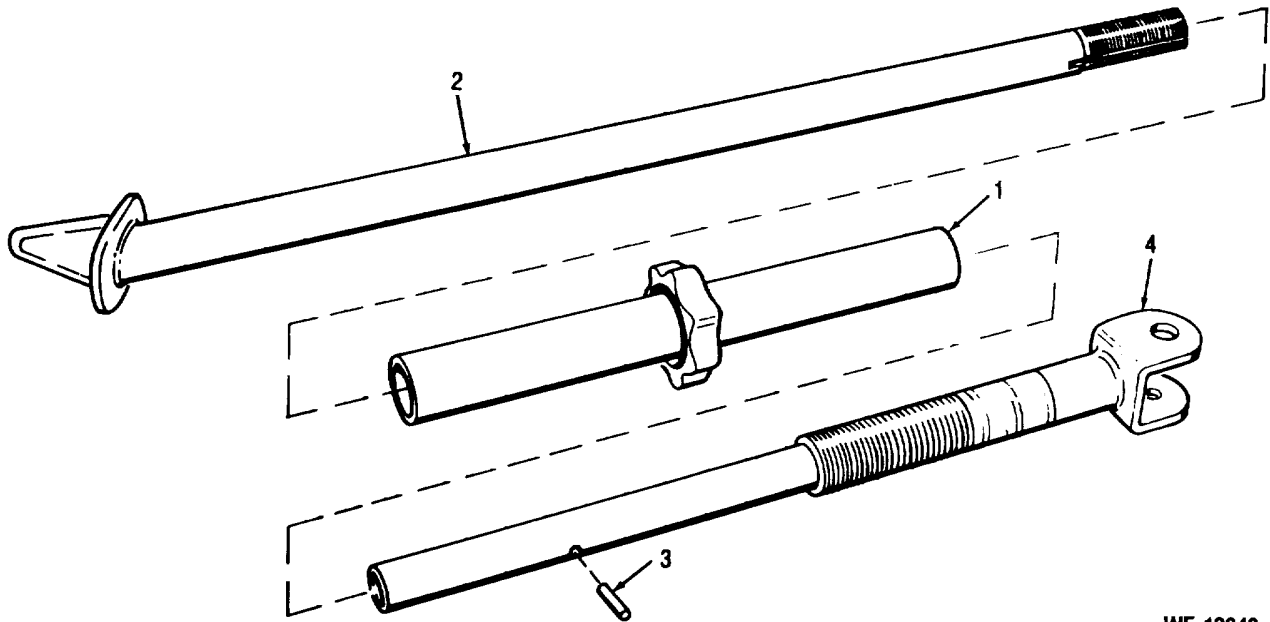

WE 13849

Figure C-17. Tripod lower front leg group - exploded view

(1) ILLUSTRATION (a) FIG NO.		(2) SMR CODE	(3) NATIONAL STOCK NUMBER	(4) PART NUMBER	(5) FSCM	(6) DESCRIPTION USABLE ON CODE	(7) U/M	(8) QTY INC IN UNIT
C-17	1	PAFZZ	6920-00-867-5326	11578692	19206	TRIPOD LOWER FRONT LEG GROUP	EA	3
C-17	2	PAFZZ	6920-00-867-5328	11578685	19206	SLEEVE, LEG ADJUSTING	EA	2
C-17	3	PAFZZ	6920-00-867-5325	11578710	19206	LEG, LOWER FRONT	EA	3
C-17	4	PAFZZ	6920-00-867-5321	11578688	19206	PIN, SPRING LEG, UPPER	EA	3

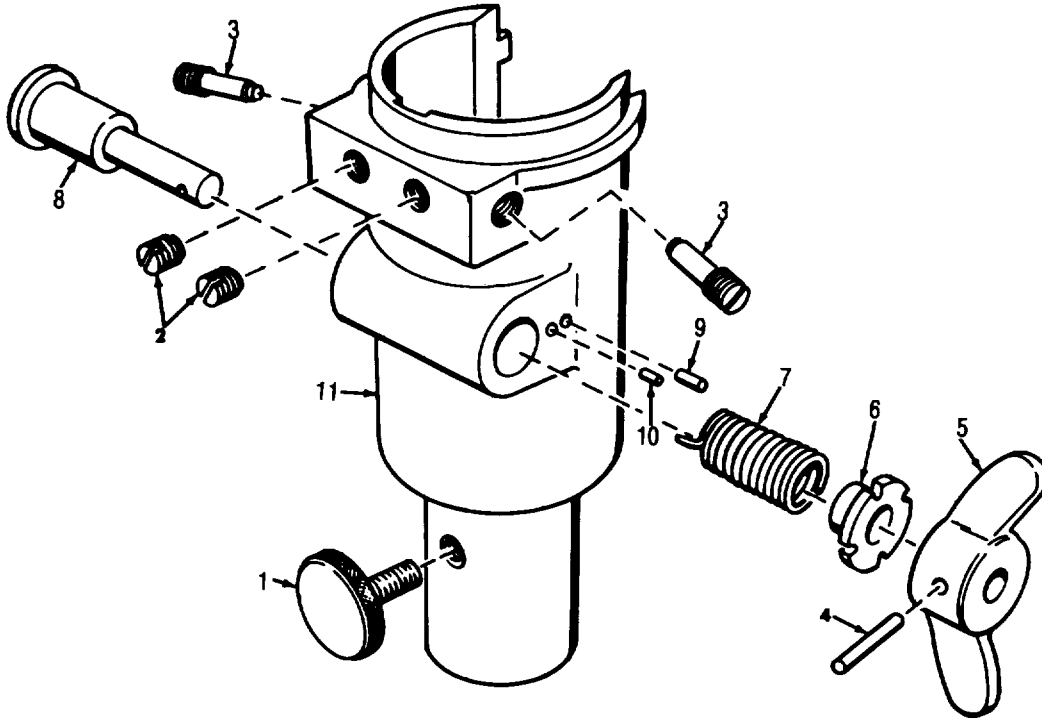

AR 902791

Figure C- 18. Telescope socket assembly or M12 series telescopes - exploded view

(1) ILLUSTRATION		(2)	(3)	(4)	(5)	(6)	(7)	(8)
(a) FIG NO.	(b) ITEM NO.	SMR CODE	NATIONAL STOCK NUMBER	PART NUMBER	FSCM	DESCRIPTION	USABLE ON CODE	QTY INC IN UNIT
C-18	1	PAOZZ	5305-00-069-8697	11578705	19206	TELESCOPE SOCKET ASSEMBLY		EA 1
C-18	2	PAOZZ	6920-00-867-5293	11578704	19206	SCREW, LOCKING,	PLN	EA 2
C-18	3	PAOZZ	5305-00-069-8699	11578698	19206	SETSCREW, TANGENT	PLN	EA 2
C-18	4	PAFZZ	6920-00-867-5291	11578708	19206	SCREW, TANGENT	PLN	EA 1
C-18	5	PAFZZ	6920-00-867-5305	11578702	19206	PIN, SPRING	PLN	EA 1
C-18	6	PAFZZ	6920-00-867-5290	11578701	19206	HANDLE, TELESCOPE	PLN	EA 1
C-18	7	PAFZZ	6920-00-867-5292	11578703	19206	RETAINER, SPRING	PLN	EA 1
C-18	8	PAFZZ	6920-00-867-5289	11578697	19206	SPRING, TELESCOPE LOCK	PLN	EA 1
C-18	9	PAFZZ	6920-00-867-5287	11578706	19206	LOCK, TELESCOPE	PLN	EA 1
C-18	10	PAFZZ	6920-00-867-5288	11578707	19206	PIN, SPRING	PLN	EA 1
C-18	11	XA		11578699	19206	PIN, SPRING	PLN	EA 1
						SOCKET, TELESCOPE	PLN	EA 1

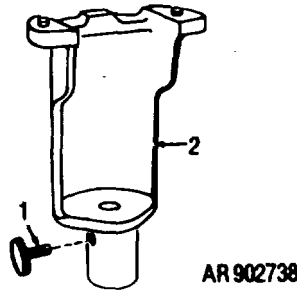

Figure C-19. Telescope support assembly for M11S/M115 telescopes - exploded view

(1) ILLUSTRATION		(2)	(3)	(4)	(5)	(6) DESCRIPTION		(7)	(8)
(a) FIG NO.	(b) ITEM NO.	SMR CODE	NATIONAL STOCK NUMBER	PART NUMBER	FSCM	USABLE ON CODE		U/M	QTY INC IN UNIT
C C-19	1	XBOZZ		11727518	19206	TELESCOPE SUPPORT ASSEMBLY		EA	1
C-19	2	XA		11727519	19206	SCREW, LOCKING, TELESCOPE HOLDER, TELESCOPE		EA	1

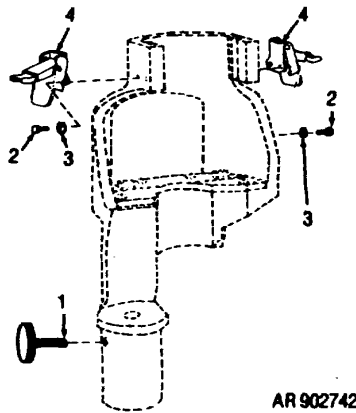
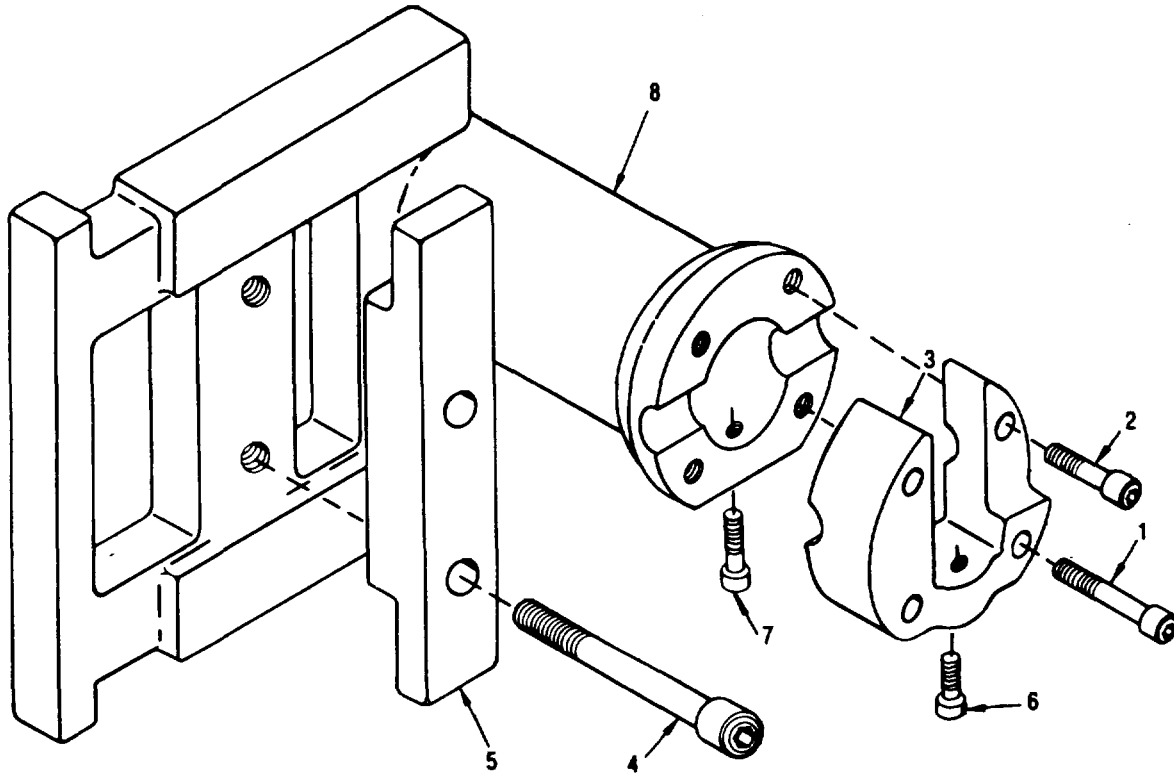

Figure C-20. Telescope support assembly for M117 telescopes - exploded view

(1) ILLUSTRATION		(2)	(3)	(4)	(5)	(6) DESCRIPTION		(7)	(8)
(a) FIG NO.	(b) ITEM NO.	SMR CODE	NATIONAL STOCK NUMBER	PART NUMBER	FSCM	USABLE ON CODE		U/M	QTY INC IN UNIT
C C-20	1	XBOZZ		11727518	19206	TELESCOPE SUPPORT ASSEMBLY		EA	1
C C-20	2	PAFZZ	5305-00-054-6650	MS51957-26	96906	SCREW, LOCKING, TELESCOPE		EA	4
C C-20	3	PAFZZ	5310-00-616-3555	MS35333-71	96906	SCREW		EA	4
C C-20	4	PAFZZ	5340-00-984-5206	10531763-4	19200	WASHER		EA	4
						CATCH		EA	2



AR 902744

Figure C-21. Adapter assembly for M101A1- exploded view

(1) ILLUSTRATION (a) FIG NO.	(2) ITEM NO.	(3) SMR CODE	(4) NATIONAL STOCK NUMBER	(5) PART NUMBER	(6) FSCM	(7) DESCRIPTION USABLE ON CODE	(8) QTY INC U/M IN UNIT
C-21	1	PAOZZ	5305-00-983-6625	MS16997-84	96906	ADAPTER ASSEMBLY FOR M101A1I	EA 3
C-21	2	PAOZZ	5305-00-983-6622	MS16997-81	96906	SCREW, SOCKET HEAD CAP	EA 1
C-21	3	XBOZZ		11578778	19206	SCREW, SOCKET HEAD CAP	EA 1
C-21	4	PAOZZ	5305-00-983-7469	MS16997-152	96906	CAP	EA 1
C-21	5	XBOZZ		11578839	19206	SCREW, SOCKET HEAD	EA 2
C-21	6	PAOZZ	5305-00-983-6663	MS16998-45	96906	BAR, LOCKING CAP	EA 1
C-21	7	PAOZZ	5305-00-983-6663	MS1699846	96906	SCREW, SOCKET HEAD CAP	EA 1
C-21	8	XBOZZ		11578838	19206	SCREW, SOCKET HEAD	EA 1
						BODY, ADAPTER	EA 1

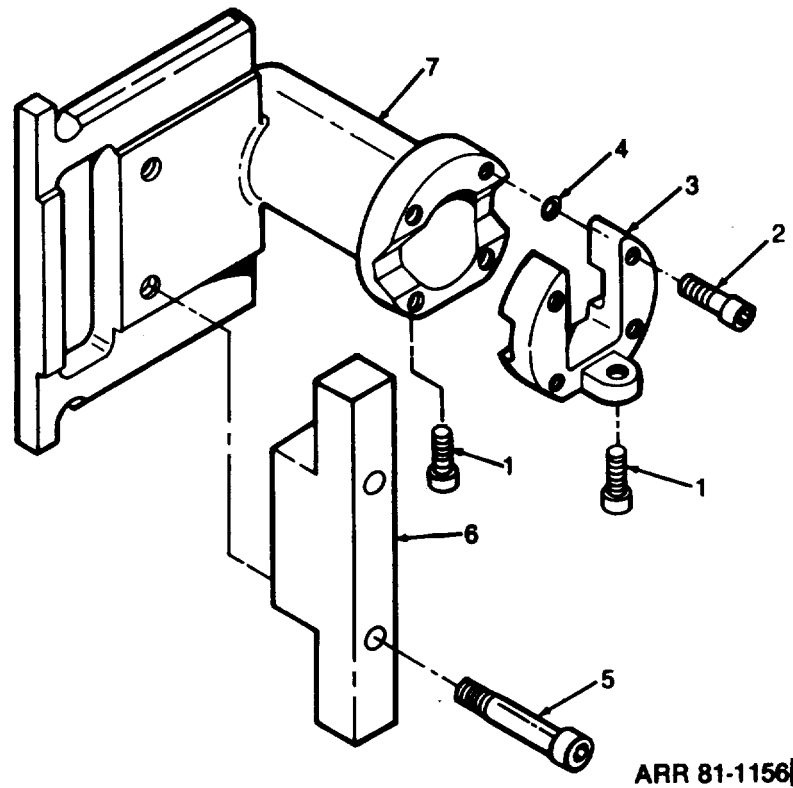

ARR 81-1156

Figure C-21A. Adapter assembly for M101A1 - optional manufacture

(1) ILLUSTRATION		(2)	(3)	(4)	(5)	(6)	(7)	(8)
(a) FIG NO.	(b) ITEM NO.	SMR CODE	NATIONAL STOCK NUMBER	PART NUMBER	FSCM	DESCRIPTION USABLE ON CODE	U/M	QTY INC IN UNIT
NC-21A	1	PAOZZ	5305-00-983-6625	MS16998-45	96906	ADAPTER ASSEMBLY FOR M101A1		
NC-21A	1	PAOZZ	5305-00-983-6662	MS16998-45	96906	SCREW, SOCKET HEAD: 1/4-28x1	PLD	EA 2
NC-21A	1	PAOZZ	5305-00-983-6662	MS16998-45	96906	SCREW, SOCKET HEAD: 5/16-18x1-1/4	PLD	EA 4
NC-21A	3	XBOZZ		11578868	19206	CAP	PLQ	EA 1
NC-21A	4	PAOZZ	5365-01-114-0186	11578950	19206	RING, SCREW RETAINING	PLR	EA 4
NC-21A	5	PAOZZ	5305-00983-7469	MS16997-152	96906	SCREW, CAP SOCKET HEAD	PLB	EA 2
NC-21A	6	XBOZZ		11578866	19206	BAR, LOCKING	PLB	EA 1
NC-21A	7	XBOZZ		11578865	19206	BODY, ADAPTER	PLB	EA 1

Change 1 C-24.1

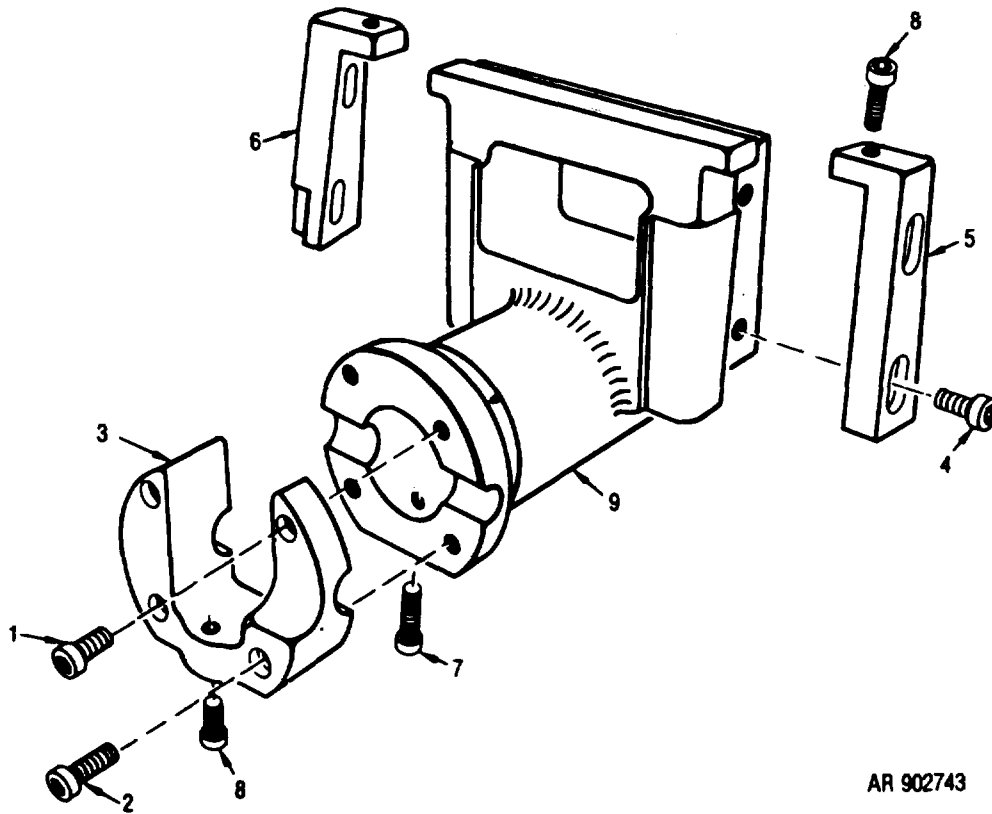

AR 902743

Figure C-22. Adapter assembly for M102 - exploded view

(1) ILLUSTRATION (a) FIG NO.		(2) SMR CODE	(3) NATIONAL STOCK NUMBER	(4) PART NUMBER	(5) FSCM	(6) DESCRIPTION USABLE ON CODE	(7) U/M	(8) QTY INC IN UNIT
R	C-22 1	PAOZZ	5305-00-983-6625	MS16997-84	96906	ADAPTER ASSEMBLY FOR M102 SCREW, SOCKET HEAD CAP	PLD	EA 3
	C-22 2	PAOZZ	5305-00-983-6622	MS16997-81	96906	SCREW, SOCKET HEAD CAP	PLD	EA 1
	C-22 3	XBOZZ		11578778	19206	CAP	PLD	EA 1
	C-22 4	PAOZZ	5305-00914-3818	MS51985-8	96906	SCREW, SOCKET HEAD CAP	PLD	EA 1
	C-22 5	XBOZZ		11578777-1	19206	GIB, RIGHT	PLK	EA 1
	C-22 6	XBOZZ		11578777-2	19206	GIB, LEFT	PLK	EA 1
	C-22 7	PAOZZ	5305-00-983-6663	MS1699846	96906	SCREW, SOCKET HEAD CAP	PLD	EA 1
	C-22 8	PAOZZ	5305-00-983-6662	MS16998-45	96906	SCREW, SOCKET HEAD CAP	PLD	EA 3
	C-22 9	XBOZZ		11578776	19206	BODY, ADAPTER	PLK	EA 1

Change 1 C-24.2

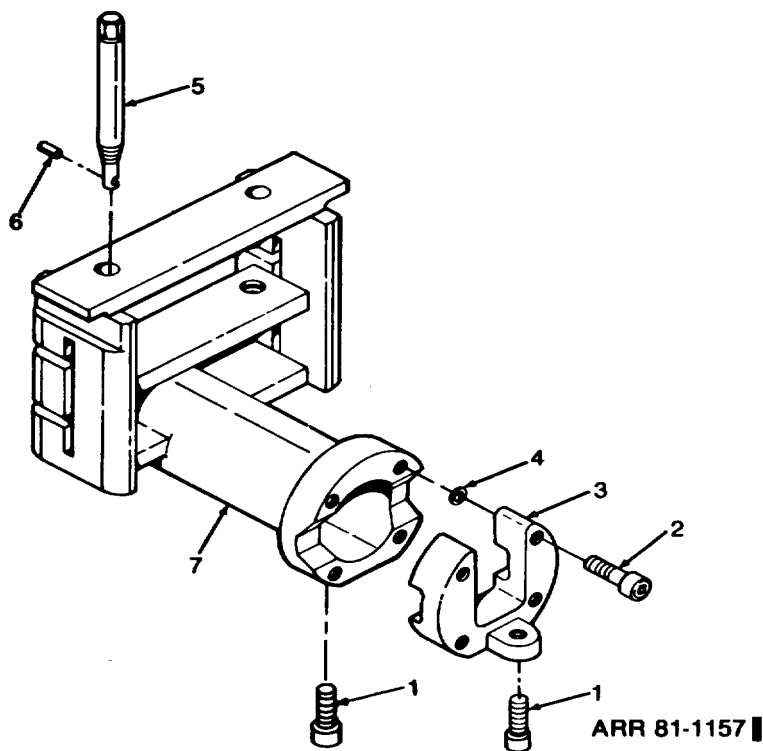
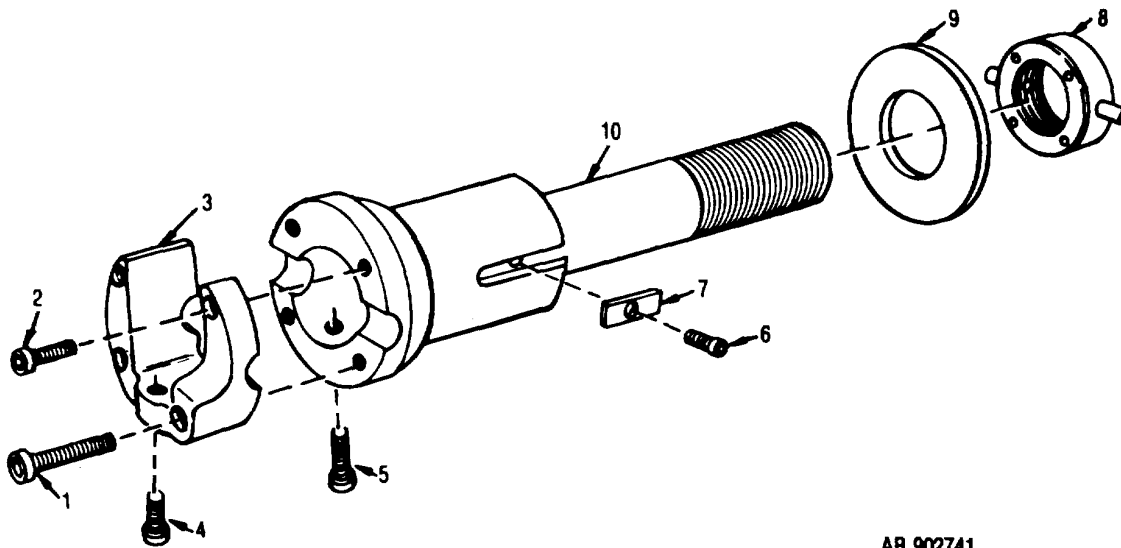

Figure C-22A. Adapter assembly for M102 - optional manufacture

(1) ILLUSTRATION		(2)	(3)	(4)	(5)	(6)	(7)	(8)
(a) FIG NO.	(b) ITEM NO.	SMR CODE	NATIONAL STOCK NUMBER	PART NUMBER	FSCM	DESCRIPTION USABLE ON CODE	U/M	QTY INC IN UNIT
N C-22A 1		PAOZZ	5305-00-983-6662	MS16998-45	96906	SCREW, SOCKET HEAD: 1/4-28x1 PLD	EA	2
N C-22A 2		PAOZZ	5306-00-983-6622	MS16997-81	96906	SCREW, SOCKET HEAD: 5/16-18x1-1/4 PLD	EA	4
N C-22A 3		XBOZZ		11578868	19206	CAP PLQ	EA	1
N C-22A 4		PAOZZ	5365-01-114-0186	11578950	19206	RING, SCREW PLR	EA	4
N C-22A 5		XBOZZ		11578969	19206	SCREW, LOCK PLK	EA	2
N C-22A 6		PAOZZ	5315-00-710-2735	MS16562-122	96906	PIN, SPRING PLK	EA	2
N C-22A 7		XBOZZ		11578968	19206	BODY, ADAPTER PLK	EA	1



AR 902741

Figure C-23. Adapter assembly for M 14 and M114AI - exploded view

	(1) ILLUSTRATION		(2) SMR CODE	(3) NATIONAL STOCK NUMBER	(4) PART NUMBER	(5) FSCM	(6) DESCRIPTION		(7) U/M	(8) QTY INC IN UNIT
	(a) FIG NO.	(b) ITEM NO.					USABLE ON CODE			
							ADAPTER ASSEMBLY FOR M114 AND M114A1			
I	C-23	1	PAOZZ	5305-00-983-6625	MS16997-84	96906	SCREW, SOCKET HEAD CAP	PLD	EA	3
	C-23	2	PAOZZ	5305-00-983-6622	MS16997-81	96906	SCREW, SOCKET HEAD CAP	PLD	EA	1
C	C-23	3	XBOZZ		11578778	19206	CAP	PLD	EA	1
	C-23	4	PAOZZ	5305-00-983-6662	MS1699845	96906	SCREW, SOCKET HEAD CAP	PLD	EA	1
	C-23	5	PAOZZ	5305-00-983-6663	MS1699846	96906	SCREW, SOCKET HEAD CAP	PLD	EA	1
	C-23	6	PAOZZ	5305-00-983-6648	MS16998-9	96906	SCREW, SOCKET HEAD CAP	PLP	EA	1
R	C-23	7	PAOZZ	6920-01-020-7832	11578836	19206	KEY	PLM	EA	1
	C-23	8	XBOZZ		11578834	19206	NUT ASSEMBLY	PLM	EA	1
	C-23	9	XBOZZ		11578837	19206	WASHER	PLM	EA	1
	C-23	10	XBOZZ		11578835	19206	BODY ASSEMBLY	PLM	EA	1

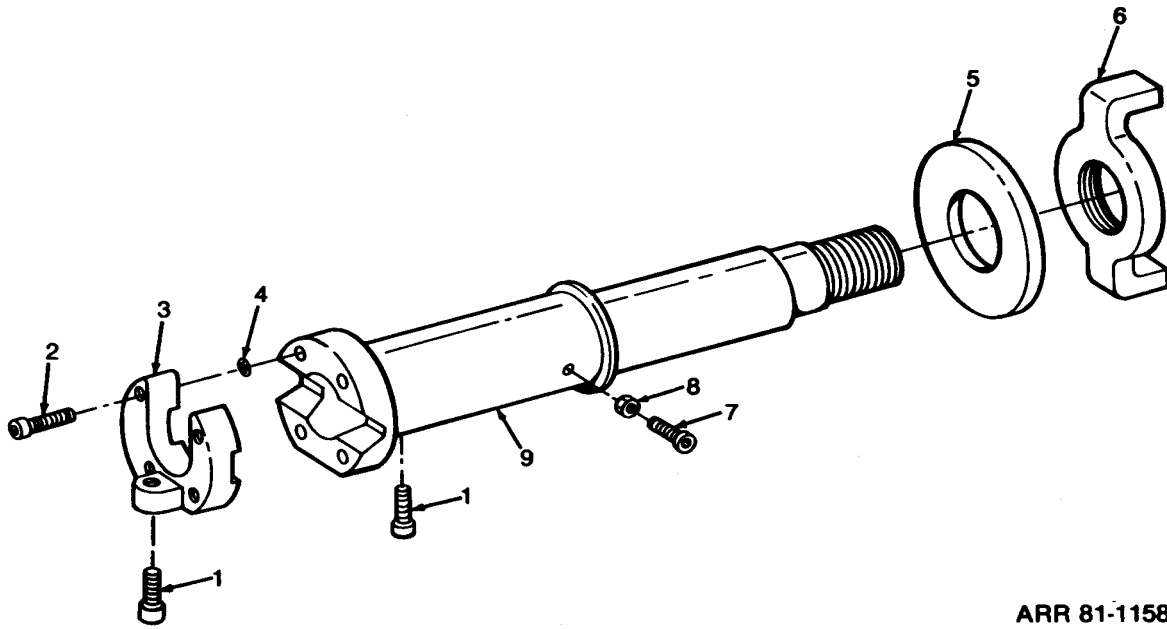
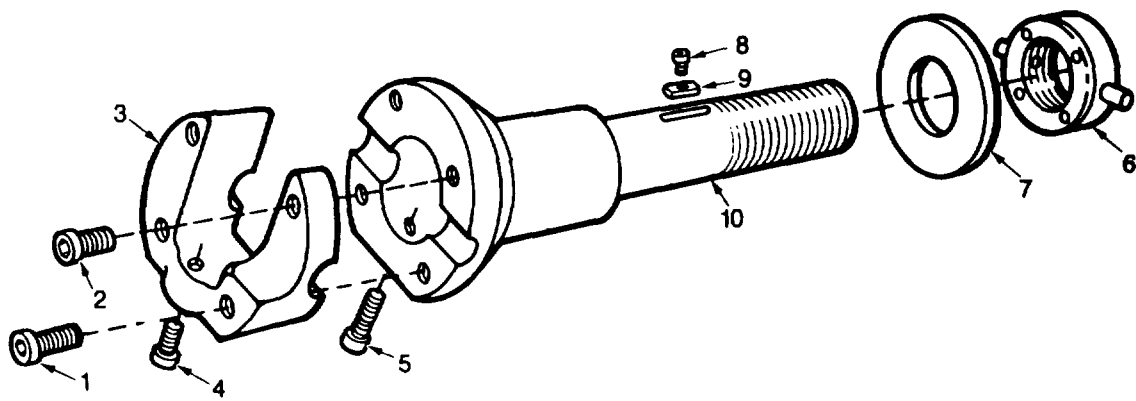

Figure C-23A. Adapter assembly for M114A - optional manufacture

ARR 81-1158

(1) ILLUSTRATION		(2)	(3)	(4)	(5)	(6)	(7)	(8)
(a) FIG NO.	(b) ITEM NO.	SMR CODE	NATIONAL STOCK NUMBER	PART NUMBER	FSCM	DESCRIPTION USABLE ON CODE	U/M	QTY INC IN UNIT
						ADAPTER ASSEMBLY FOR M114A1		
NC-23A	1	PAOZZ	5305-00-983-6662	MS1699845	96906	SCREW, SOCKET HEAD: 1/4-28x1 PLD	EA	2
FC-23A	2	PAOZZ	5305-00-983-6622	MS16997-81	96906	SCREW, SOCKET HEAD: 5/16-18x1-114 PLD	EA	4
C-23A	3	XBOZZ		11578868	19206	CAP PLQ	EA	1
NC-23A	4	PAOZZ	5365-01-114-0186	11578960	19206	RING, SCREW RETAINING PLR	EA	4
NC-23A	5	XBOZZ		11578871-2	19206	WASHER PLM	EA	1
NC23A	6	XBOZZ		11678869-2	19206	NUT PLM	EA	1
NC-23A	7	PAOZZ		11578878	19206	SCREW(MODIFIED) PLM	EA	1
NC-23A	8	PAOZZ		MS35691-526	96906	NUT, JAM PLM	EA	1
NC-23A	9	XBOZZ		11578877	19206	BODY, ADAP'ER PLM	EA	1



AR 902740

Figure C-24. Adapter assembly for M107/M109/M109A1/M110 - exploded view

(1) ILLUSTRATION		(2)	(3)	(4)	(5)	(6) DESCRIPTION		(7)	(8)
(a) FIG NO.	(b) ITEM NO.	SMR CODE	NATIONAL STOCK NUMBER	PART NUMBER	FSCM	USABLE ON CODE		U/M	QTY INC IN UNIT
						ADAPTER ASSEMBLY FOR M107/M109/M109A1/M110			
C-24	1	PAOZZ	5305-00-983-6625	MS16997-84	96906	SCREW, SOCKET HEAD CAP	PLD	EA	3
C-24	2	PAOZZ	530-00-983-6622	MS16997-81	96906	SCREW, SOCKET HEAD CAP	PLD	EA	1
C-24	3	XBOZZ		11578778	19206	CAP	PLA	EA	1
C-24	4	PAOZZ	5305-00-983-662	MS1699845	96906	SCREW, SOCKET HEAD CAP	PLD	EA	1
C-24	5	PAOZZ	5305-00-983-6663	MS1699846	96906	SCREW, SOCKET HEAD CAP	PLD	EA	1
C-24	6	XBOZZ		11578779	19206	NUT ASSEMBLY	PLA	EA	1
C-24	7	XBOZZ		11578783	19206	WASHER	PLA	EA	1
C-24	8	PAOZZ	5305-00-983-6648	MS16998-9	96906	SCREW, SOCKET HEAD CAP	PLP	EA	1
R C-24	9	PAOZZ	6920-01-011-8156	11578784	19206	KEY	PLM	EA	1
C-24	10	XBOZZ		11578781	19206	BODY, ADAPTER	PLA	EA	1

Change 1 C-26.2

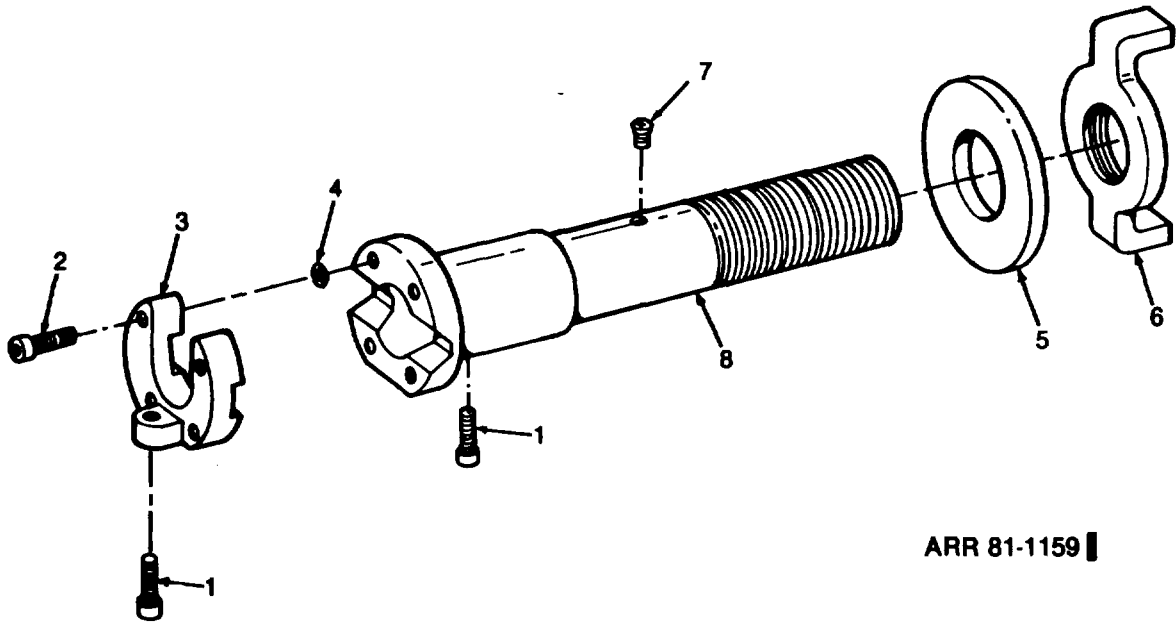

ARR 81-1159

Figure C-24A. Adapter assembly for M109/M109A1/M110 - optional manufacture

(1) ILLUSTRATION		(2) SMR CODE	(3) NATIONAL STOCK NUMBER	(4) PART NUMBER	(5) FSCM	(6) DESCRIPTION	USABLE ON CODE	(7) U/M	(8) QTY INC IN UNIT
(a) FIG NO.	(b) ITEM NO.								
N C-24A	1	PAOZZ	5305-00-983-6662	MS16998-45	96906	ADAPTER ASSEMBLY FOR M109/M109A1/ M109A2/M110A2			
N C-24A	2	PAOZZ	5305-00-983-6622	MS16997-81	96906	SCREW, SOCKET HEAD: 1/4-28x1	PLD	EA	2
N C-24A	3	XBOZZ		11578868	19206	SCREW, SOCKET HEAD: 5/16-18x1-114	PLD	EA	4
N C-24A	4	PAOZZ	5366-01-114-0186	11578950	19206	CAP	PLQ	EA	1
N C-24A	5	XBOZZ		11578871-1	19206	RING, SCREW RETAINING	PLR	EA	4
N C-24A	6	XBOZZ		11578869-1	19206	WASHER	PLA	EA	1
N C-24A	7	PAOZZ		11578872	19206	NUT	PLS	EA	1
N C-24A	8	XBOZZ		11578867	19206	SCREW(MODIFIED)	PLA	EA	1
						BODY, ADAPTER	PLA	EA	1

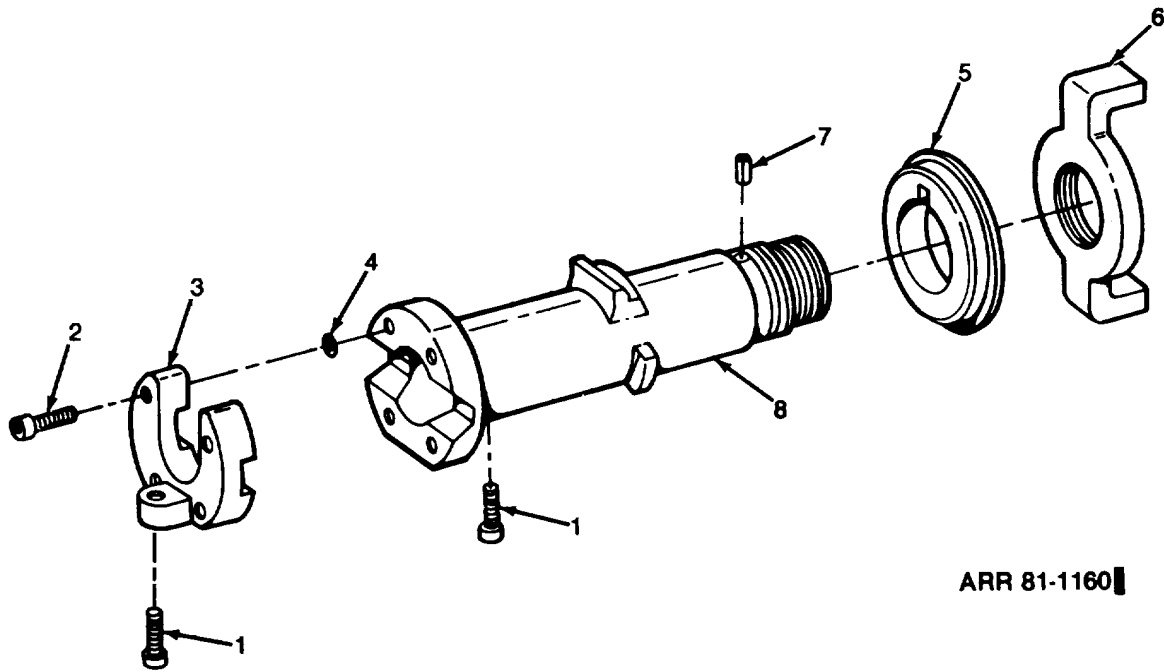

ARR 81-1160

Figure C-24B. Adapter assembly for M198

(1) ILLUSTRATION		(2)	(3)	(4)	(5)	(6)	(7)	(8)
(a) FIG NO. UNIT	(b) ITEM NO.	SMR CODE	NATIONAL STOCK NUMBER	PART NUMBER	FSCM	DESCRIPTION USABLE ON CODE	U/M	QTY INC IN
						ADAPTER ASSEMBLY FOR M198		
NC-24B	1	PAOZZ	5305-00-983-6662	MS16998-45	96906	SCREW, SOCKET HEAD: 1/4-28x1 PLD	EA	2
NC-24B	2	PAOZZ	5305-00-983-6622	MS16997-81	96906	SCREW, SOCKET HEAD: 5/16-18x1-1/4 PLD	EA	4
NC-24B	3	XBOZZ		11578868	19206	CAP PLQ	EA	1
NC-24B	4	PAOZZ	5365-01-114-0186	11578950	19206	RING, SCREW PLR	EA	4
NC-24B	5	XBOZZ		11579603	19206	WASHER, STEP PLQ	EA	1
NC-24B	6	XBOZZ		11578869-1	19206	NUT PLS	EA	1
NC-24B	7	PAOZZ	5315058-6111	MS16562-140	96906	PIN, SPRING PLQ	EA	1
NC-24B	8	XBOZZ		11579604	19206	BODY, ADAPTER PLQ	EA	1

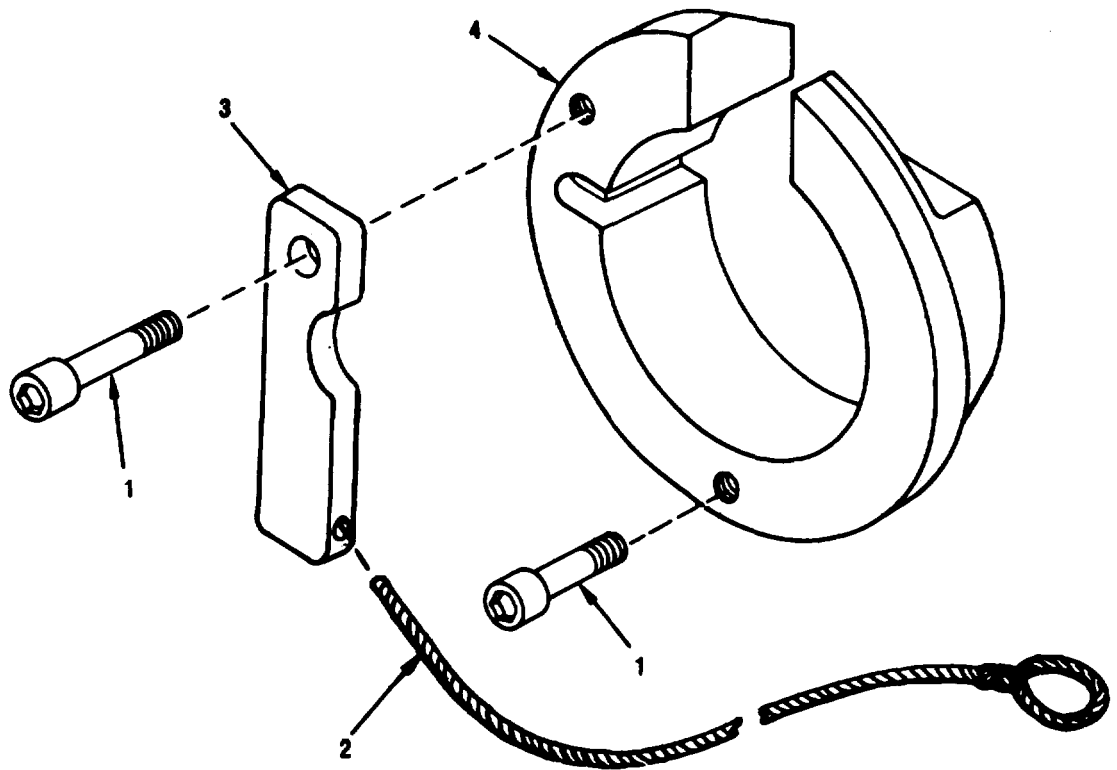

AR 902730

Figure C-25. Lanyard ring assembly, 14.5mm gun - exploded view

(1) ILLUSTRATION		(2)	(3)	(4)	(5)	(6) DESCRIPTION		(7)	(8)
(a) FIG NO.	(b) ITEM NO.	SMR CODE	NATIONAL STOCK NUMBER	PART NUMBER	FSCM		USABLE ON CODE	U/M	QTY INC IN UNIT
						LANYARD RING ASSEMBLY			
C-25	1	PAOZZ	5305-00-939-0661	MS1975-1	96906	SCREW, SOCKET HEAD CAP: 10-24UNC-3/8	PLD	EA	2
R C-25	2	PAOZZ	6920-01-011-8155	11578774	19206	LANYARD, BRAIDED	PLD	EA	1
C-25	3	XBOZZ		11578773	19206	LEVER	PLD	EA	1
C-25	4	XDOZZ		1578771	19206	HOLDER	PLD	EA	1

Change 1 C-28.1

Section V. SPECIAL TOOLS LIST

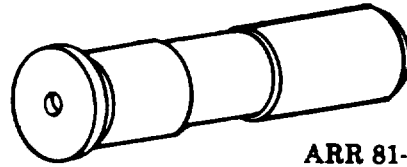

ARR 81-1845

Figure C-26. Headspace gage

(1) ILLUSTRATION		(2)	(3)	(4)	(5)	(6)	(7)	(8)
(a) FIG NO.	(b) ITEM NO.	SMR CODE	NATIONAL STOCK NUMBER	PART NUMBER	FSCM	DESCRIPTION USABLE ON CODE	U/M	QTY INC IN UNIT
N C-26	1	PAFZZ	6920-01-025-4596	11578863	19206	HEADSPACE GAGE	EA	1

Section VI. NATIONAL STOCK NUMBER AND PART NUMBER INDEX

STOCK NUMBER	FIG. No.	ITEM No.	STOCK NUMBER	FIG. No.	ITEM No.
1005-00-508-2589	C-1	2	5305-00-983-6622	C24A	2
1005-00-653-5441	C-1	4	5305-00-983-6622	C-24B	2
3020-00-867-5265	C-12	6	5305-00-983-6625	C-21	1
3020-00-867-5268	C-12	8	5305-00-983-6625	C-22	1
3020-00-867-5274	C-13	2	5305-00-983-6625	C-23	1
3020-00-867-5282	C-11	5	5305-00-983-6625	C-24	1
5305-00-054-6650	C-20	2	5305-00-983-6648	C-23	6
5305-00-069-8691	C-9	9	5305-00-983-6648	C-24	8
5305-00-069-8692	C-6	6	5305-00-983-6662	C-21	6
5305-00-069-8693	C-13	4	5305-00-983-6662	C-21A	1
5305-00-069-8694	C-9	3	5305-00-983-6662	C-22	8
5305-00-069-8695	C-7	1	5305-00-983-6662	C-22A	1
5305-00-069-8697	C-18	1	5305-00-983-6662	C-23	4
5305-00-069-8698	C-8	4	5305-00-983-6662	C-23A	1
5305-00-069-8699	C-18	3	5305-00-983-6662	C-24	4
5305-00-069-8700	C-6	1	5305-00-983-6662	C-24A	1
5305-00-069-8700	C-12	9	5305-00-983-6662	C-24B	1
5305-00-069-8701	C-4	1	5305-00-983-6663	C-21	7
5305-00-069-8702	C-5	8	5305-00-983-6663	C-22	7
5305-00-069-8703	C-5	1	5305-00-983-6663	C-23	5
5305-00-069-8704	C-16	2	5305-00-983-6663	C-24	5
5305-00-069-8705	C-15	3	5305-00-983-7469	C-21	4
5305-00-069-8706	C-15	5	5305-00-983-7469	C-21A	5
5305-00-914-3818	C-22	4	5306-00-871-8488	C-14	4
5305-00-939-0661	C-25	1	5306-00-871-8490	C-16	6
5305-00-983-6622	C-21	2	5310-00-616-3555	C-20	3
5305-00-983-6622	C-21A	2	5315-00-058-6111	C-24B	7
5305-00-983-6622	C-22	2	5315-00-236-8345	C-5	3
5305-00-983-6622	C-22A	2	5315-00-710-2735	C-22A	6
5305-00-983-6622	C-23	2	5340-00-984-5206	C-20	4
5305-00-983-6622	C-23A	2	5360-00-867-5251	C-10	4
5305-00-983-6622	C-24	2			

STOCK NUMBER	FIG. No.	ITEM No.	STOCK NUMBER	FIG. No.	ITEM No.
5360-00-867-5257	C-8	7	6920-00-867-5286	C-9	10
5360-00-867-5280	C-9	6	6920-00-867-5287	C-18	9
5360-00-867-5281	C-9	7	6920-00-867-5288	C-18	10
5360-00-867-5303	C-4	4	6920-00-867-5289	C-18	8
5360-00-867-5311	C-5	12	6920-00-867-5290	C-18	6
5360-00-950-2997	C-5	6	6920-00-867-5291	C-18	4
5360-00-950-2997	C-5	10	6920-00-867-5292	C-18	7
5360 00-993-7572	C-4	9	6920-00-867-5293	C-18	2
			6920-00-867-5294	C-5	11
5360-00-993-7572	C-4	14	6920-00-867-5296	C-4	12
5365-01-114-0186	C-21A	4	6920-00-867-5297	C-4	7
5365-01-114-0186	C-22A	4	6920-00-867-5299	C-4	11
5365-01-114-0186	C-23A	4	6920-00-867-5300	C-4	10
5365-01-114-0186	C-24A	4	6920-00-867-5301	C-4	6
5365-01-114-0186	C-24B	4	6920-00-867-5302	C-4	5
6920-00-095-2576	C-3	4	6920-00-867-5304	C-8	8
6920-00-095-2578	C-3	1	6920-00-867-5305	C-18	5
6920-00-345-8947	C-3	2	6920-00-967-5306	C-5	9
6920-00-345-8949	C-3	3			
			6920-00-867-5308	C-4	2
6920-00-378-9823	C-2	1	6920-00-867-5309	C-5	13
6920-00-378-9824	C-2	2	6920-00-867-5310	C-5	15
6920-00-456-5968	C-2	3	6920-00-867-5313	C-5	14
6920-00-867-5246	C-10	3	6920-00-867-5314	C-5	7
6920-00-867-5248	C-10	5	6920-00-867-5317	C-5	4
6920-00-867-5249	C-10	2	6920-00-867-5318	C-5	5
6920-00-867-5252	C-6	5	6920-00-867-5320	C-5	2
6920-00-867-5253	C-6	4	6920-00-867-5321	C-16	11
6920-00-867-5255	C-6	7	6920-00-867-5321	C-17	4
6920-00-867-5258	C-11	4			
6920-00-867-5258	C-12	2	6920-00-867-5323	C-14	2
6920-00-867-5259	C-10	1	6920-00-867-5323	C-16	4
			6920-00-867-5324	C-14	1
6920-00-867-5259	C-11	3	6920-00-867-5324	C-16	3
6920-00-867-5259	C-12	1	6920-00-867-5325	C-16	10
6920-00-867-5259	C-12	2	6920-00-867-5325	C-17	3
6920-00-867-5260	C-12	7	6920-00-867-5326	C-16	8
6920-00-867-5261	C-12	3	6920-00-867-5326	C-17	1
6920-00-867-5262	C-12	5	6920-00-867-5328	C-17	2
6920-00-867-5263	C-12	11	6920-00-867-5329	C-16	9
6920-00-867-5264	C-12	4	6920-00-867-5330	C-16	1
6920-00-867-5267	C-12	10	6920-00-867-5332	C-16	7
6920-00-867-5269	C-8	2	6920-00-867-5333	C-15	6
6920-00-867-5270	C-8	1	6920-00-867-5334	C-7	5
6920-00-867-5271	C-6	3	6920-00-867-5334	C-15	2
6920-00-867-5272	C-13	1	6920-00-867-5335	C-15	4
6920-00-867-5272	C-14	3	6920-00-867-6588	C-11	7
6920-00-867-5272	C-16	5	6920-00-867-8878	C-9	4
6920-00-867-5273	C-13	3	6920-00-867-8879	C-4	8
6920-00-867-5275	C-13	5	6920-00-868-5662	C-4	3
6920-00-867-5276	C-9	5	6920-00-927-1157	C-4	13
6920-00-867-5277	C-11	6	5310-01-056-7463	C-6	2
6920-00-867-5278	C-11	2	6920-01-011-8155	C-25	2
6920-00-867-5279	C-11	1	6920-01-011-8156	C-24	9
6920-00-867-5283	C-7	6	6920-00-020-7832	C-23	7
6920-00-867-5284	C-7	3	6290-01-025-4596	C-26	1
6920-00-867-5285	C-8	5			

STOCK NUMBER	FIG. No.	ITEM No.	STOCK NUMBER	FIG. No.	ITEM No.
6920-01-040-1486	C-1	3	7520-00-935-9815	C-1	1
6920-01-117-3637	C-3	5			

PART NUMBER	FSCM	FIG. NO.	ITEM NO.	PART NUMBER	FSCM	FIG. NO.	ITEM NO.
L-B-00565	81348	C-1	1	10531763-4	19206	C-20	4
MS16562-122	96906	C-22A	6	11578578	19206	C-4	2
MS16562-140	96906	C-24B	7	11578600	19206	C-4	12
MS16997-152	96906	C-21	4	11578601	19206	C4	3
MS16997-152	96906	C-21A	5	11578604	19204	C-5	15
MS16997-81	96906	C-21	2	11578606	19206	C-4	6
MS16997-81	96906	C-21A	2	11578607	19206	C-5	14
MS16997-81	96906	C-22	2	11578608	19206	C-4	8
MS16997-81	96906	C-22A	2	11578609	19206	C-4	10
MS16997-81	96906	C-23	2	11578610	19206	C-4	5
MS16997-81	96906	C-23A	2	11578611	19206	C-4	13
MS16997-81	96906	C-24	2	11578612	19206	C-4	1
MS16997-81	96906	C-24A	2	11578613	19206	C-4	4
MS16997-81	96906	C-24B	2	11578615	19206	C-9	5
MS16997-84	96906	C-21	1	11578617	19206	C-5	4
MS16997-84	96906	C-22	1	11578618	19206	C-10	2
MS16997-84	96906	C-23	1	11578619	19206	C-10	5
MS16997-84	96906	C-24	1	11578620	19206	C-9	11
MS16998-45	96906	C-21	6	11578621	19206	C-13	5
MS16998-45	96906	C-21A	1	11578622	19206	C-5	8
MS16998-45	96906	C-22	8	11578623	19206	C-5	5
MS16998-45	96906	C-22A	1	11578624	19206	C-5	7
MS16998-45	96906	C-23	4	11578628	19206	C-5	13
MS16998-45	96906	C-23A	1	11578630	19206	C-5	11
MS16998-45	96906	C-24	4	11578631	19206	C-4	7
MS16998-45	96906	C-24A	1	11578632	19206	C-5	9
MS16998-45	96906	C-24B	1	11578635	19206	C-11	5
MS16998-46	96906	C-21	7	11578636	19206	C-8	4
MS16998-46	96906	C-22	7	11578637	19206	C-10	3
MS16998-46	96906	C-23	5	11578638	19206	C-6	6
MS16998-46	96906	C-24	5	11578639	19206	C-11	6
MS16998-9	96906	C-23	6	11578640	19206	C-6	3
MS16998-9	96906	C-24	8	11578641	19206	C-9	7
MS24585-C10	96906	C4	9	11578642	19206	C-9	6
MS24585-C10	96906	C4	14	11578643	19206	C-13	2
MS24585-C12	96906	C4	11	11578644	19206	C-9	4
MS24585-C282	96906	C-8	7	11578645	19206	C-6	4
MS24585-C49	96906	C-5	12	11578646	19206	C-6	5
MS24585-C80	96906	C-5	6	11578647	19206	C-6	7
MS24585-C80	96906	C-5	10	11578648	19206	C-8	5
MS24665-5	96906	C-5	3	11578649	19206	C-8	8
MS35333-71	96906	C-20	3	11578650	19206	C-12	6
MS35691-526	96906	C-23A	8	11578651	19206	C- 1	4
MS51957-26	96906	C-20	2				
MS51975-1	96906	C-25	1				
MS51985-8	96906	C-22	4				

PART NUMBER	FSCM	FIG. NO.	ITEM NO.	PART NUMBER	FSCM	FIG. NO.	ITEM NO.
	19206	C-12	2	11578703	19206	C-18	7
11578652	19206	C-12	7	11578704	19206	C-18	2
11578653	19206	C-12	10	11578705	19206	C-18	1
11578654	19206	C-9	10	11578706	19206	C-18	9
11578655	19206	C-8	2	11578707	19206	C-18	10
11578656	19206	C-12	8	11578708	19206	C-18	4
11578657	19206	C-6	1	11578709	19206	C-12	11
11578657	19206	C-12	9	11578710	19206	C-16	10
11578658	19206	C-12	5	11578710	19206	C-17	3
11578659	19206	C-7	6	11578711	19206	C-16	2
11578660	19206	C-10	4	11578712	19206	C-16	1
11578661	19206	C-11	7	11578713		C-8	6
11578662	19206	C-9	3	11578714	19206	C-7	2
11578664	19206	C-11	1	11578715	19206	C-7	4
11578665	19206	C-11	2	11578715	19206	C-15	1
11578666	19206	C-13	4	11578716	19206	C-7	5
11578667	19206	C-13	1	11578716	19206	C-15	2
11578667	19206	C-14	3	11578717	19206	C-15	3
11578667	19206	C-16	5	11578718	19206	C-23	3
11578668	19206	C-13	3	11578746	19206	C-7	1
11578669	19206	C-8	1	11578747	19206	C-7	3
11578672	19206	C-12	4	11578749	19206	C-3	2
11578673	19206	C-12	3	11578750	19206	C-3	1
11578678	19206	C-6	2	11578752	19206	C-3	3
11578679	19206	C-9	9	11578754	19206	C-8	3
11578080	19206	C-10	1	11578755		C-9	8
11578680	19206	C-11	3	11578756		C-9	1
11578680	19206	C-12	1	11578757		C-9	2
11578681	19206	C-14	2	11578763	19206	C-1	3
11578681	19206	C-16	4	11578764	19206	C-5	1
11578682	19206	C-15	5	11578771	19206	C-25	4
11578683	19206	C-15	4	11578773	19206	C-25	3
11578684	19206	C-16	7	11578774	19206	C-25	2
11578685	19206	C-17	2	11578776	19206	C-22	9
11578688	19206	C-16	11	11578777-1	19206	C-22	5
11578688	19206	C-17	4	11578777-2	19206	C-22	6
11578689	19206	C-15	6	11578778	19206	C-21	3
11578690	19206	C-16	9	11578778	19206	C-22	3
11578691	19206	C-14	1	11578778	19206	C-24	3
11578691	19206	C-16	3	11578779	19206	C-24	6
11578692	19206	C-16	8	11578780	19206	C-3	4
11578692	19206	C-17	1	11578781	19206	C-24	10
11578693	19206	C-14	4	11578783	19206	C-24	7
11578694	19206	C-16	6	11578784	19206	C-24	9
11578695	19206	C-5	2	11578834	19206	C-23	8
11578697	19206	C-18	8	11578835	19206	C-23	10
11578698	19206	C-18	3	11578836	19206	C-23	7
11578699	19206	C-18	11	11578837	19206	C-23	9
11578700	19206	C-2	1	11578838	19206	C-21	8
11578701	19206	C-18	6	11578839	19206	C-21	5
11578702	19206	C-18	5				

Change 1 C-31

PART NUMBER	FSCM	FIG. NO.	ITEM NO.	PART NUMBER	FSCM	FIG. NO.	ITEM NO.
11578865	19206	C-21A	7	11578950	19206	C-21A	4
11578866	19206	C-21A	6	11578950	19206	C-22A	4
11578867	19206	C-24A	8	11578950	19206	C-23A	4
11578868	19206	C-21A	3	11578950	19206	C-24A	4
11578868	19206	C-22A	3	11578967	19206	C-3	1
11578868	19206	C-23A	3	11578968	19206	C-22A	7
11578868	19206	C-24A	3	11578969	19206	C-22A	5
11578868	19206	C-24B	3	11579603	19206	C-24B	5
11578869-1	19206	C-24A	6	1]579604	19206	C-24B	8
11578869-1	19206	C-24B	6]1579605	19206	C-3	5
11578869-2	19206	C-23A	6	11727518	19206	C-19	1
11578870	19206	C-3	4	11727518	19206	C-20	1
11578871-1	19206	C-24A	5	11727519	19206	C-19	2
11578871-2	19206	C-23A	5	11727520		C-2	3
11578872	19206	C-24A	7	11728907		C-2	2
11578873	19206	C-3	2	6535441	19206	C-1	4
11578876	19206	C-3	3	8407954	19206	C-1	2
11578877	19206	C-23A	9				
11578878	19206	C-23A	7				

Change 1 C-32

INDEX

Subject	Paragraph	Page
A		
Adapter Assemblies	1-4d	1-4
Adapter Assembly for M101A1 Howitzer.....	1-4d	1-4
Adapter Assembly for M102 Howitzer.....	1-4d	1-4
Adapter Assembly for M107/M110 Vehicles	1-4d	1-4
Adapter Assembly for M114A1 Howitzer.....	1-4d	1-4
Adapter Assembly for M198 Howitzer	1-4d	1-4
Ammunition		
Ammunition Types.....	7-2	7-1
Ballistic Data	7-4	7-1
Cartridges	7-3	7-1
Cookoff	2-14d	2-26
Hangfire	2-14d	2-26
Markings	7-5	7-1
Misfire	2-14d	2-26
Packaging	7-6	7-1
Preparation for Firing.....	7-7	7-1
Assembly, Mount	7-7	7-1
B		
Barrel Assembly	1-4c	1-3
Basic Issue Items	1-7	1-7
Boresighting	2-13b	2-25
C		
Consumable and Expendable Supplies	1-9	1-8
Cookoff (ammunition)	2-14d	2-26
D		
Description	1-4	1-1
Differences Between Kits	1-5	1-5
Direct Support Maintenance Instructions Consumable Supplies	5-3	5-1
Inspections		
Initial	5-6	5-3
In-Process	5-6	5-3
Repair Parts	5-1	5-1
Special Tools and Equipment.....	5-2	5-1

Subject	Paragraph	Page
Troubleshooting.....	5-4	5-2
Direct Support Maintenance Repair Instructions		
Cleaning		
Disassembly and Assembly Procedures.....	6-2	6-1
Final Inspection.....	6-24	6-13
Finished Surfaces.....	6-9	6-1
Maintenance		
Bolt Assembly.....	6-11	6-2
Mount Assembly.....	6-15	6-3
Tripod Mount Assembly.....	6-18	6-10
Telescope Socket, Holder, and Support Assemblies.....	6-21	6-12
Painting.....	6-7	6-1
Repairing Damaged Threads.....	6-6	6-1
Replacement of Parts.....	6-3	6-1
Use of Tools 64.....	6-4	6-1
Welding.....	6-5	6-1
E		
End-for-End Test.....	2-6c	2-15
F		
Federal Aviation Administration (FAA) Notification.....	2-2d	2-3
Field Artillery Trainer Kits, List of.....	1-2	1-1
Firing Range		
Construction.....	2-2e	2-3
Site Selection.....	2-2a	2-1
Surface Danger Zone.....	2-2c	2-1
Types.....	2-2b	2-1
Firing Range Maps		
Permanent and Semipermanent.....	2-3a	2-10
Temporary.....	2-3b	2-10
Firing the Trainer.....	2-14	2-25
H		
Hangfire (ammunition).....	2-14d	2-26
I		
Inspecting and Servicing the Equipment.....	2-5	2-12
Inspections		
Final.....	6-24	6-13

Subject	Paragraph	Page
Initial	5-6	5-3
In-Process	5-6	5-3
Installation Instructions for the:		
M101A1 Howitzer	2-8	2-17
M102 Howitzer.....	2-9	2-19
M109/M109A1/M110/M115 Howitzer and M107 Gun	2-7	2-15
M114A1 Howitzer	2-10	2-21
Items Troop Installed or Authorized	1-8	1-8

L

Lanyard Ring Assembly.....	1-4e	1-6
List of Field Artillery Trainer Kits.....	1-2	1-1
Lubrication Chart	3-4	3-1

M

Maps for Firing Ranges		
Permanent and Semipermanent	2-3a	2-10
Temporary	2-3b	2-10
Maps for a Temporary Range	2-3b	2-10
Maps for Permanent and Semipermanent Ranges	2-3a	2-10
Misfire (ammunition)	2-14d	2-26
Mount Assembly	1-4b	1-2
M101A1 Howitzer, Adapter Assembly for.....	1-4d	1-4
M102 Howitzer, Adapter Assembly for	1-4d	1-4
M107/M110 Vehicles, Adapter Assembly for	1-4d	1-4
M114A1 Howitzer, Adapter Assembly for.....	1-4d	1-4
M198 Howitzer, Adapter Assembly for	1-4d	1-4

N

Notification of Federal Aviation Administration (FAA)	2-2d	2-3
-------------------------------------------------------------	------	-----

O

Operating Instructions		
Preparation for Operation		
Constructing a Firing Range		
Federal Aviation Administration (FAA)		
Notification	2-2d	2-3
Range Construction	2-2e	2-3
Select a Range Site	2-2a	2-1
Surface Danger Zone	2-2c	2-1
Types of Ranges.....	2-2b	2-1

Subject	Paragraph	Page
Constructing a Map for the Range		
Maps for Permanent and Semipermanent Ranges.....	2-3a	2-10
Maps for a Temporary Range.....	2-3b	2-10
Survey Requirements.....	2-3c	2-11
Service Upon Receipt of Equipment		
General	2-4	2-12
Inspecting and Servicing the Equipment.....	2-5	2-12
Installation Instructions for the:		
M101A1 Howitzer	2-8	2-17
M102 Howitzer.....	2-9	2-19
M109/M109A1/M110/M115 Howitzer and M107 Gun.....	2-7	2-15
M114A1 Howitzer	2-10	2-21
M198 Howitzer.....	2-10.1	2-22.1
Setting-Up Instructions for the M31 Trainer		
Assembly	2-6a	2-12
Boresighting.....	2-6b	2-14
End-for-End Test	2-6c	2-15
Operation Under Unusual Conditions		
Cold Climates	2-17	2-27
General	2-16	2-27
Hot Climates	2-18	2-27
Operation Under Usual Conditions		
Firing the Trainer		
Cookoff (ammunition)	2-14d	2-26
Extraction.....	2-14c	2-26
Firing	2-14b	2-25
Hangfire (ammunition)	2-14d	2-26
Loading	2-14a	2-25
Misfire (ammunition)	2-14d	2-26
General	2-11	2-23
Preparation for Firing		
Assembly and Installation.....	2-13a	2-25
Boresighting.....	2-13b	2-25
Services After Firing.....	2-15	2-27
Training Procedures		
Fire Direction Center Procedures.....	2-12c	2-24
Firing Battery Procedures.....	2-12a	2-23
Observer Procedures	2-12b	2-23
Operator Maintenance Instructions		

Subject	Paragraph	Page
Cleaning and Lubricating Instructions		
Adapter Assemblies	3-4e	3-1
Barrel Assembly	34a	3-1
General	3-3	3-1
Mount Assembly	3-4b	3-1
Telescope Socket, Holder, and Support Assemblies	3-4d	3-1
Tripod Mount Assembly	3-4c	3-1
Maintenance Instructions		
Firing Pin and Spring	3-9	3-4
Operator's Preventive Maintenance	3-6	3-3
Preventive Maintenance Checks and Services		
General	3-5	3-3
Repair Parts	3-1	3-1
Special Tools and Equipment	3-2	3-1
Troubleshooting	3-7	3-4
Organizational Maintenance Instructions		
Maintenance		
Barrel Assembly	4-8	4-3
Breech Bolt Group	4-7	4-2
Mount Assembly	4-9	4-4
Telescope Socket, Holder, or Support Assembly	4-11	4-4
Tripod Mount Assembly	4-10	4-4
Maintenance of Adapter Assemblies for:		
105-MM Howitzer M101A1	4-12a	4-4
105-MM Howitzer M102	4-12b	4-4
155-MM Howitzer M109, 175-MM Gun M107, and 8-Inch Howitzer M110	4-12d	4-7
155-MM Howitzer M114 and M114A1	4-12c	4-7
155-MM Howitzer M198	4-12e	4-7
Preventive Maintenance Checks and Services	4-4	4-1
Removal and Installation of Major Components	4-6	4-2
Repair Parts	4-1	4-1
Special Tools and Equipment	4-2	4-1
P		
Preparation for Operation	2-1	2-1
R		
Range Construction	2-2e	2-3
Range site Selection	2-2a	2-1

Subject	Paragraph	Page
Ranges, type of	2-2b	2-2
Repair Parts		
Direct Support Maintenance.....	5-1	5-1
Operator Maintenance.....	3-1	3-1
Required Surface Danger Zone Dimensions.....	2-2c	2-2

S

Scope	1-1	1-1
Service Upon Receipt of Equipment	2-4	2-12
Setting-Up Instructions for the M31 Trainer		
Assembly	2-4a	2-12
Boresighting	2-6b	2-14
End-for-End Test.....	2-6c	2-15
Shipment and Limited Storage		
Cleaning and Drying.....	8-2	8-1
Marking	8-4	8-1
Preservation and Packaging	8-3	8-1
Shipping	8-1	8-1
Special Tools and Equipment		
Direct Support Maintenance.....	5-2	5-1
Operator Maintenance.....	3-2	3-1
Supplies, Consumable and Expendable	1-9	1-8
Surface Danger Zone	2-2c	2-1
Survey Requirements	2-3c	2-11

T

Tabulated Data	1-6	1-6
Training Procedures	2-12	2-23
Troubleshooting		
Direct Support Maintenance.....	5-4	5-2
Operator Maintenance.....	3-7	3-4
Types of Ammunition	7-2	7-1

By Order of the Secretary of the Army:

FRED C. WEYAND
General, United States Army
Chief of Staff

Official:

PAUL T. SMITH
Major General, United States Army
The Adjutant General

Distribution:

To be distributed in accordance with DA Form 12-40, Organizational maintenance requirements for Trainer, Field Artillery:
14.5 MM, M31.

The Correct SUPERSESSION NOTE should read:

This manual supersedes TM 9-6920-221-13, 27 October 1966, including all changes.

☆U.S. GOVERNMENT PRINTING OFFICE : 1993 O - 342-421 (80206)

RECOMMENDED CHANGES TO EQUIPMENT TECHNICAL PUBLICATIONS



SOMETHING WRONG WITH THIS PUBLICATION?

FROM: (PRINT YOUR UNIT'S COMPLETE ADDRESS)

DATE SENT

THEN... JOT DOWN THE DOPE ABOUT IT ON THIS FORM, CAREFULLY TEAR IT OUT, FOLD IT AND DROP IT IN THE MAIL!

PUBLICATION NUMBER

PUBLICATION DATE

PUBLICATION TITLE

BE EXACT... PIN-POINT WHERE IT IS				IN THIS SPACE TELL WHAT IS WRONG AND WHAT SHOULD BE DONE ABOUT IT:
PAGE NO.	PARA-GRAPH	FIGURE NO.	TABLE NO.	

PRINTED NAME, GRADE OR TITLE, AND TELEPHONE NUMBER

SIGN HERE:

TEAR ALONG PERFORATED LINE

DA FORM 2028-2 JUL 79

PREVIOUS EDITIONS ARE OBSOLETE.

P.S.—IF YOUR OUTFIT WANTS TO KNOW ABOUT YOUR RECOMMENDATION MAKE A CARBON COPY OF THIS AND GIVE IT TO YOUR HEADQUARTERS.

THE METRIC SYSTEM AND EQUIVALENTS

WEIGHT MEASURE

1 Centimeter = 10 Millimeters = 0.01 Meters = 0.3937 Inches
 1 Meter = 100 Centimeters = 1000 Millimeters = 39.37 Inches
 1 Kilometer = 1000 Meters = 0.621 Miles

WEIGHTS

1 Gram = 0.001 Kilograms = 1000 Milligrams = 0.035 Ounces
 1 Kilogram = 1000 Grams = 2.2 lb.
 1 Metric Ton = 1000 Kilograms = 1 Megagram = 1.1 Short Tons

LIQUID MEASURE

1 Milliliter = 0.001 Liters = 0.0338 Fluid Ounces
 1 Liter = 1000 Milliliters = 33.82 Fluid Ounces

SQUARE MEASURE

1 Sq. Centimeter = 100 Sq. Millimeters = 0.155 Sq. Inches
 1 Sq. Meter = 10,000 Sq. Centimeters = 10.76 Sq. Feet
 1 Sq. Kilometer = 1,000,000 Sq. Meters = 0.386 Sq. Miles

CUBIC MEASURE

1 Cu. Centimeter = 1000 Cu. Millimeters = 0.06 Cu. Inches
 1 Cu. Meter = 1,000,000 Cu. Centimeters = 35.31 Cu. Feet

TEMPERATURE

$5/9(^{\circ}\text{F} - 32) = ^{\circ}\text{C}$
 212° Fahrenheit is equivalent to 100° Celsius
 90° Fahrenheit is equivalent to 32.2° Celsius
 32° Fahrenheit is equivalent to 0° Celsius
 $9/5^{\circ}\text{C} + 32 = ^{\circ}\text{F}$

APPROXIMATE CONVERSION FACTORS

TO CHANGE	TO	MULTIPLY BY
Inches	Centimeters	2.540
Feet	Meters	0.305
Yards	Meters	0.914
Miles	Kilometers	1.609
Square Inches	Square Centimeters	6.451
Square Feet	Square Meters	0.093
Square Yards	Square Meters	0.836
Square Miles	Square Kilometers	2.590
Acres	Square Hectometers	0.405
Cubic Feet	Cubic Meters	0.028
Cubic Yards	Cubic Meters	0.765
Fluid Ounces	Milliliters	29.573
its	Liters	0.473
arts	Liters	0.946
allons	Liters	3.785
Ounces	Grams	28.349
Pounds	Kilograms	0.454
Short Tons	Metric Tons	0.907
Pound-Feet	Newton-Meters	1.356
Pounds per Square Inch	Kilopascals	6.895
Miles per Gallon	Kilometers per Liter	0.425
Miles per Hour	Kilometers per Hour	1.609

TO CHANGE	TO	MULTIPLY BY
Centimeters	Inches	0.394
Meters	Feet	3.280
Meters	Yards	1.094
Kilometers	Miles	0.621
Square Centimeters	Square Inches	0.155
Square Meters	Square Feet	10.764
Square Meters	Square Yards	1.196
Square Kilometers	Square Miles	0.386
Square Hectometers	Acres	2.471
Cubic Meters	Cubic Feet	35.315
Cubic Meters	Cubic Yards	1.308
Milliliters	Fluid Ounces	0.034
Liters	Pints	2.113
Liters	Quarts	1.057
ers	Gallons	0.264
ms	Ounces	0.035
ograms	Pounds	2.205
Metric Tons	Short Tons	1.102
Newton-Meters	Pounds-Feet	0.738
Kilopascals	Pounds per Square Inch	0.145
ometers per Liter	Miles per Gallon	2.354
ometers per Hour	Miles per Hour	0.621



PIN: 015431-000